



MARK PESTRELLA, Director

COUNTY OF LOS ANGELES

DEPARTMENT OF PUBLIC WORKS

"To Enrich Lives Through Effective and Caring Service"

900 SOUTH FREMONT AVENUE
ALHAMBRA, CALIFORNIA 91803-1331
Telephone: (626) 458-5100
<http://dpw.lacounty.gov>

ADDRESS ALL CORRESPONDENCE TO:
P.O. BOX 1460
ALHAMBRA, CALIFORNIA 91802-1460

IN REPLY PLEASE
REFER TO FILE: **BRC-1**
003430

August 13, 2018

Ms. Judith Helaine Ware, President/Chief Executive Officer
Ware Disposal, Inc.
P.O. Box 1318
Santa Ana, CA 92702

Dear Ms. Ware:

TRANSMITTAL OF EXECUTED CONTRACT

Enclosed is your copy of Contract No. 003430 for work entitled Lennox Garbage Disposal District as approved by the Board of Supervisors and executed by the Director of Public Works. This Contract commenced today, August 13, 2018.

Please continue to submit the required proof of insurance and performance bond to: County of Los Angeles Department of Public Works, Business Relations and Contracts Division, Attention Mr. David Pang, Contract No. 003430, via scanned e-mail to dpang@dpw.lacounty.gov.

Your Public Works Contract Manager for this service will be Mr. Steve Milewski of our Environmental Programs Division who may be reached at (626) 458-3573, Monday through Thursday, 7 a.m. to 5:30 p.m.

Ms. Ghayane Zakarian serves as Public Works Ombudsman for service contracts; therefore, please call Ms. Zakarian if you encounter a problem that cannot be resolved by the Contract Manager. She can be reached at (626) 300-3224, Monday through Thursday, 7 a.m. to 5 p.m.

Ms. Judith Helaine Ware
August 13, 2018
Page 2

Follow us on Twitter:

We encourage you to follow us on Twitter [@LACoPublicWorks](https://twitter.com/LACoPublicWorks) for information on Public Works and instant updates on contracting opportunities and solicitations.

Very truly yours,

MARK PESTRELLA
Director of Public Works



for: JOSE M. QUEVEDO
Assistant Deputy Director
Business Relations and Contracts Division

DP

P:\aepubl\Service Contracts\CONTRACT\David\GDD\2018\LENNOX & MALIBU\Contract\Ware\TRANS EXE CONTRACT 08.13.18.doc

Enc.

CONTRACTOR EXECUTE

Contract

No. 003430



BY AND BETWEEN

**THE COUNTY OF LOS ANGELES GARBAGE DISPOSAL
DISTRICT**

AND

WARE DISPOSAL, INC.

FOR

**LENNOX GARBAGE DISPOSAL DISTRICT
(2018-GDD017)**

Contract

No. 003430



BETWEEN

COUNTY OF LOS ANGELES BOARD OF SUPERVISORS
ACTING IN THEIR CAPACITY AS THE GOVERNING BOARD OF
THE LENNOX GARBAGE DISPOSAL DISTRICT

AND

WARE DISPOSAL, INC.

FOR PROVISION OF

REFUSE, RECYCLABLES, AND GREEN WASTE CONTAINER SERVICES TO
CUSTOMERS AT RESIDENTIAL, MULTIFAMILY, AND COMMERCIAL PREMISES
(TASK 1 SERVICES)

AND

ABANDONED WASTE COLLECTION SERVICES
AND MAINTENANCE OF PUBLIC RECEPTACLES
(TASK 2 SERVICES) (2018-GDD017)

FOR THE SERVICE AREA OF

LENNOX

WITH A SERVICE COMMENCEMENT DATE OF

AUGUST 13, 2018

TABLE OF CONTENTS

CONTRACT FOR LENNOX GARBAGE DISPOSAL DISTRICT (2018-GDD017)

SECTION 0 - RECITALS:..... 0-1

SECTION 1 - REQUIREMENTS TO PROVIDE TASK 1 SERVICES..... 1-4

 A. Grant of Rights 1-4

 B. Exclusions from Service 1-5

 C. Future Exclusions from Exclusivity 1-7

 D. Definition of Rights 1-8

 E. No Longer Used 1-8

 F. Privacy (Contract Services) 1-8

 G. Ownership of Solid Waste 1-8

SECTION 2 - TERM OF CONTRACT 2-9

 A. Term of Contract Services 2-9

 B. Obligations Upon Expiration or Termination of CONTRACT 2-10

 C. Undepreciated Assets 2-12

SECTION 3 - SCOPE OF SERVICES AND SPECIFICATIONS (Contract Services) 3-13

 A. Prescribed Scope 3-13

 B. Change in Scope of Services 3-14

 C. No Longer Used 3-14

 D. CONTRACTOR Documentation (Contract Services)..... 3-14

SECTION 4 - SERVICE STANDARDS..... 4-16

 A. Public Health and Safety; Nuisances (Contract Services) 4-16

 B. Private Property (Task 1 Services) 4-17

 C. Non-Collection (Contract Services) 4-18

 D. Nondiscrimination 4-20

 E. CONTRACTOR Waste Reduction Practices (Contract Services) 4-20

 F. Customer Correspondence and Other Materials (Task 1 Service) 4-20

 G. Publicity and News Media Relations..... 4-20

 H. Responsiveness to County (Contract Services) 4-21

 I. No Commingling of Solid Waste 4-22

 J. Key Personnel (Contract Services)..... 4-22

 K. Uniforms (Contracts) 4-23

 L. Confidentiality (Contracts) 4-23

 M. Single-Pass Collection (Task 1)..... 4-23

SECTION 5 - ADDITIONAL PERFORMANCE OBLIGATIONS 5-25

SECTION 6 - CUSTOMER SERVICE (Task 1 Services) 6-26

 A. Facilities..... 6-26

 B. Telephone Service..... 6-26

 C. Paperless/Electronic Information and Services 6-27

 D. Responses to Customer Complaints and Other Correspondence 6-29

 E. Service Interruption 6-30

 F. Responsiveness to Customer..... 6-30

 G. Setting Up or Terminating Service 6-31

SECTION 7 - SERVICE FEES AND BILLING 7-32

 A. Customer Service Fees 7-33

 B. Customer Invoice and Payment..... 7-34

 C. County Service and Fees 7-38

SECTION 8 - WASTE CHARACTERIZATION STUDY 8-44

 A. Participate with County Study 8-44

 B. Perform Study 8-44

SECTION 9 - RECORDS 9-45

 A. Record Maintenance and Retention 9-45

 B. County Custody 9-45

 C. Inspection and Review of Records 9-46

 D. Copies of Audits 9-46

 E. Submission of Records 9-47

 F. Public Record Request 9-47

SECTION 10 - REPORTS 10-48

 A. Types and Content 10-48

 B. Submission of Reports 10-50

 C. Reporting Adverse Information 10-50

 D. County's Right to Request Information 10-51

SECTION 11 - SUBSTITUTE, EMERGENCY, AND BACK-UP SERVICE 11-52

 A. Director's Right to Provide Contract Services 11-52

 B. Emergency Assistance (Contract Services) 11-54

 C. Backup Service Plan 11-57

 D. Use of Goods, Services and Property 11-57

SECTION 12 - ENFORCEMENT OF CONTRACT 12-60

 A. As Provided by Law 12-60

 B. COUNTY's Additional Remedies 12-60

 C. Injunctive Relief 12-60

 D. Recovery of Damages 12-61

 E. County's Reimbursement Costs 12-63

 F. Waiver 12-63

SECTION 13 - UNPERMITTED WASTE SCREENING AND REPORTING (Contract Services) 13-64

 A. Protocol 13-64

 B. Prohibition on Collection 13-64

 C. Notice to Director 13-64

 D. Labels 13-64

SECTION 14 - EXECUTION OF CONTRACT 14-65

 A. Execution in Counterparts 14-65

 B. Authority to Execute 14-65

SECTION 15 - PERFORMANCE ASSURANCE 15-66

 A. Performance Bonds, Other Security 15-66

 B. Further Assurances 15-67

SECTION 16 - CONTRACT SERVICE AREA INFORMATION 16-69

 A. Maps 16-69

 B. Sample Graphics 16-69

 C. Data 16-69

 D. Outreach 16-69

 E. SWIMS 16-70

THIS CONTRACT is made and entered on August 9, 2018, by and between COUNTY of Los Angeles Board of Supervisors, acting in their capacity as the governing body of the Lennox Garbage Disposal District of COUNTY of Los Angeles (COUNTY), and Ware Disposal, Inc., a Corporation registered in the State of California (CONTRACTOR).

RECITALS:

Purpose. To limit the wear and tear on COUNTY streets, reduce pollution from Collection Vehicle exhaust, increase customer service accountability, ensure compliance with Federal, State, and local laws, including Assembly Bill (AB) 939, by improving program implementation performance and reporting accuracy, and facilitate more efficient CONTRACT administration and enforcement by COUNTY staff.

Solid Waste Haul Permits. County of Los Angeles Department of Public Health issued permits to haulers for the hauling of solid waste with requirements to protect public health and safety, including frequency of Collection and Collection Vehicle maintenance. CONTRACTOR shall continue to obtain that permit and comply with all its provisions; and

Mandatory Solid Waste Diversion. The State of California has found and declared that the amount of solid waste generated in California coupled with diminishing landfill space and potential adverse environmental impacts from land filling have created an urgent need for State of California and local agencies to enact and implement an aggressive, new integrated waste management program. Through enactment of AB 939, the State of California has directed agencies, such as COUNTY to Divert 50 percent of all solid waste through source reduction, recycling, and composting activities. The California Department of Resources Recycling and Recovery (CalRecycle) had granted COUNTY a time line to achieve compliance with the AB 939 Diversion requirements to which COUNTY had met. Continued compliance is based in part on executing and implementing this CONTRACT to secure cooperation with CONTRACTOR'S AB 939 waste Diversion programs, record keeping, and reporting; and

County Waste Management Plan. COUNTY Board of Supervisors adopted the Roadmap to a Sustainable Waste Management Future in 2015. It is a comprehensive plan for a waste free future and is a proactive approach to developing innovative policies for managing waste that further reduces COUNTY's reliance on landfills. It established the following intermediate and long-term disposal reduction targets: 80 percent Diversion from landfills by 2025, 90 percent Diversion from landfills by 2035, and at least 95 percent Diversion from landfills by 2045; and

Task 1: Waste Discarded in Containers. COUNTY'S Director has determined to contract for Collection of Municipal Solid Waste (MSW) Management Services in portions of COUNTY under the terms of this CONTRACT for reasons including the following:

- To assist residents and certain businesses located in the Service Area that discard solid waste in Carts and Dumpsters to receive quality MSW Management Services, and
- To provide COUNTY with programs, records, and reports that will help COUNTY comply with AB 939 and other laws.

COUNTY issued a 5-year notice under California Public Resources Code (PRC) Section 49520 of COUNTY'S intent to authorize, among other options, the exclusive franchising of MSW Management Services in portions of COUNTY; and

Task 2: Abandoned Waste Collection. COUNTY'S Director has also determined to contract for collection of Abandoned Waste in this CONTRACT to efficiently remove it and prevent the illegal dumping from becoming a community eyesore, decreasing neighborhood property values, posing a safety hazard, providing a breeding ground for disease carrying rodents, insects, and other vermin, and in general, lowering the quality of life for residents.

Garbage Disposal Districts. The use of the term COUNTY is understood to mean Lennox Garbage Disposal District of COUNTY of Los Angeles. COUNTY of Los Angeles Board of Supervisors acts in their capacity as the governing body of the Garbage Disposal District. Furthermore, the COUNTY may adjust the number of Refuse Units subject to Section 7, Unit Counts and Payment Rates. The DISTRICT may adjust the initial monthly unit rate of compensation set forth in Form PW-2.2 (Schedule of Prices) subject to Exhibit 7 and Section 7.

Compliance with Law. CONTRACTOR shall perform Contract Services in accordance with all the laws governing the safe collection, transport, recycling, and disposal of Residential and Commercial Solid Waste, including but not limited to AB 939 and AB 1826, Recovered Conservation and Recovery Act (RCRA), and Comprehensive Environmental Response Compensation and Liability Act (CERCLA).

CONTRACTOR / "Arranger". Under this Contract, COUNTY may exercise control over the disposal or other disposition of the Solid Waste handled by the CONTRACTOR. It may designate or determine the use of any given Solid Waste Facility. Although minimum scope of Contract Services, Service Specifications, and Service Standards are set forth in this CONTRACT, COUNTY has not, and by this CONTRACT does not, supervise Contract Services or assume title to Solid Waste; and

Competitive Procurement. COUNTY issued a Request for Proposals (RFP) or Invitation for Bids (IFB) to provide Contract Services under this CONTRACT. Private waste hauling companies submitted proposals or bids, including their proposed schedule of rates and charges. For GDD services, COUNTY selected a CONTRACTOR based on price proposals only.

Compensation. The following describes the compensation allowed under this CONTRACT:

- The CONTRACTOR's bid on form PW-2.1, Schedule of Prices in Attachment 7-5, specifies the flat monthly payment rate for which the CONTRACTOR has agreed to perform the Customer Services described and specified herein upon commencement of this CONTRACT.
- The COUNTY agrees, in consideration of satisfactory performance of the foregoing services in strict accordance with this CONTRACT's specifications to the satisfaction of Director to pay the CONTRACTOR pursuant to the Schedule of Prices set forth in the bid and attached hereto as Form PW-2.1, in Attachment 7-5,

an amount not to exceed an initial annual amount of \$1,624,639 for Task 1 Customer Service and \$678,150 for Task 2 County Service, or such greater amount as the Board may approve rate or for adjustments for cost-of-living, fuel costs, diversion/disposal fees, unforeseen additional work, and changes in law as authorized by the CONTRACT.

- Exhibit 7 provides for CONTRACTOR'S compensation under Task 1 Services. Under this CONTRACT, the CONTRACTOR cannot charge its Customers more than the Customer Service Fees in the Customer Fee Schedule in Attachment 7-2 Task 1 Service Fees in Exhibit 7.
- Exhibit 3A2 provides for CONTRACTOR's compensation under Task 2 Services and COUNTY Service Fees in Attachment 7-3 Task 2 Service Fees in Exhibit 7.
- Exhibit 11 provides for CONTRACTOR'S compensation substitute, emergency, and backup services. Under this CONTRACT, the CONTRACTOR cannot charge its COUNTY more than the rates in Attachment 11-4 Emergency Service Fees in Exhibit 11 or comparable municipal Solid Waste fees.

NOW, THEREFORE, THE PARTIES AGREE AS FOLLOWS:

This CONTRACT applies to both Contract Services (Task 1 Services and Task 2 Services), unless specifically indicated otherwise. However, Exhibit 3A1 and Exhibit 3A3 applies only to Task 1 Services, and Exhibit 3A2 applies only to Task 2 Services.

SECTION 1 - REQUIREMENTS TO PROVIDE TASK 1 SERVICES

Customer Service = Task 1 Services = Basic Service + Additional Customer Services

County Services = Task 2 Services

Contract Services = Customer Service + County Service

Additional Customer Services means all Performance Obligations prescribed in Exhibit 3A1 and Exhibit 3A3 that require a Customer Surcharge, including the more than once per week Collection frequency in item B3, more than one 96-gallon Refuse Container, or a locking Recyclables Cart.

Basic Service means all Performance Obligations prescribed in Exhibit 3A1 and Exhibit 3A3 that do not require a Customer Surcharge, including the once per week Collection frequency in item B3 and the one 96-gallon Refuse, two 96-gallon Recyclables, and two 96-gallon Green Waste Containers in item D.

Task 1 Services all Performance Obligations prescribed in Exhibit 3A1 and Exhibit 3A3 for Refuse, Recyclables, and Green Waste Container services to Occupants at Residential Premises and Certain Multifamily and Commercial Premises.

Task 2 Services means all Performance Obligations prescribed in Exhibit 3A2 Abandoned Waste Collection services and Public Receptacle Collection services.

A. Grant of Rights

1. CONTRACTOR Requirements

COUNTY requires CONTRACTOR, together with the Performance Obligations, to provide Contract Services as described in Section 3.

a. *Conditions*

- CONTRACTOR is ready, willing, and able to provide Contract Services;
- CONTRACTOR meets all its Performance Obligations; and
- No CONTRACTOR Default has occurred;

b. *CONTRACTOR Acceptance*

CONTRACTOR accepts these conditions, together with Performance Obligations, subject to all terms and conditions in this CONTRACT and the exclusions in subsections B (Exclusions from Service) and C (Exclusions from Exclusivity) of this Section.

2. Nonexclusive Collection of Solid Waste

CONTRACTOR shall perform the Contract Services, as described in Section 3. CONTRACTOR acknowledges, however, that this CONTRACT does not grant the CONTRACTOR an exclusive right to provide Contract Services within the Service Area. COUNTY reserves the right to make a portion or all the Task 1 Services within the Service Area exclusive at any time in the future. COUNTY reserves the right to use its own forces or to contract with any company for a portion or all the Contract Services.

B. Exclusions from Service

1. Solid Waste to be Self-Hauled

This CONTRACT excludes the requirement to Collect, transport, and Divert/Dispose Solid Waste that Persons self-haul. Anyone, including Persons performing services other than MSW Management Services (such as roofers and gardeners) at those Premises, may collect in receptacles other than Container provided by CONTRACTOR, transport in their own Vehicles, and themselves Dispose of some or all the Solid Waste generated at those Premises.

2. COUNTY and Third-Party Agencies

This CONTRACT excludes the requirement to arrange to provide Task 1 Services to Premises owned or controlled by any of the following entities:

- COUNTY or any other entity governed by the Board of Supervisors;
- State of California;
- Federal government;
- Any city;
- Any public-school district; or
- Any entity that is excluded by Applicable Law from the obligation to subscribe to Task 1 Services under this CONTRACT.

This CONTRACT does not prohibit CONTRACTOR from executing separate contracts with those entities to provide MSW Management Services.

3. Rights Under California Public Resources Code Section 49520

a. *Exclusion*

This CONTRACT excludes the requirement to arrange for providing Contract Services with any Person who is receiving Solid Waste handling services from a solid waste enterprise that has the statutory right to continue to provide solid waste handling services to that Person under PRC Section 49520 *et seq.*

b. Acknowledgement

CONTRACTOR acknowledges:

(1) No Statutory Rights

This CONTRACT does not grant CONTRACTOR any rights under PRC Section 49250 *et seq.*

(2) Expired Term

Upon expiration of this CONTRACT, no unexpired Term will remain. CONTRACTOR will have no right to continue providing Contract Services, MSW Management Services, or Solid Waste handling services under PRC Section 49250 *et seq.*

(3) Terminated CONTRACT

If COUNTY exercises its remedy to terminate this CONTRACT for CONTRACTOR fault, CONTRACTOR will not be in compliance with the terms and conditions of this CONTRACT. In that event, CONTRACTOR will have no right to continue providing Contract Services, MSW Management Services, or Solid Waste handling services under PRC Section 49251.

(4) Contract Claims

CONTRACTOR does not have the right to make any claim under PRC Section 49520, but only under this CONTRACT.

c. Stop Contract Services / Procure New Services

Upon expiration or termination of this CONTRACT, CONTRACTOR shall stop providing Contract Services even if the expiration or termination occurs before the end of the period described in PRC Section 49520. After expiration or termination of this CONTRACT, COUNTY may reprocurer one or more agreements for MSW Management Services with CONTRACTOR or other Persons. Those agreements may be exclusive, partially exclusive, or wholly exclusive franchises, contracts, licenses, permits or otherwise, with or without competitive bidding.

4. Donation or Selling of Recyclables

This CONTRACT excludes the requirement that CONTRACTOR Collect Recyclables that Occupant donates or sells to Persons other than CONTRACTOR.

5. Collection of Food Waste or Recyclables from Commercial Franchise Carts

This CONTRACT excludes the requirement that CONTRACTOR Collect Food Waste that is separated from other Solid Waste subject to COUNTY's Non-Exclusive Commercial Franchise Agreements. For example, CONTRACTOR cannot Collect Food Waste or Recyclables from Carts provided under the Commercial Franchise agreement with COUNTY.

C. Future Exclusions from Exclusivity

While Customer Services are currently non-exclusive, as indicated in item A2 of this Section should COUNTY determine to make a portion or all the Customer Services within the Service Area exclusive in the future, the following exclusion will apply:

1. Task 2 Services – Abandoned Waste and Litter Collection Services

This CONTRACT is not exclusive in regards to County Services. COUNTY reserves the right to use its own forces or to contract with any company to Collect Abandoned Waste or empty public receptacles.

2. Emergency Services

This CONTRACT is not exclusive in regards to Collection of Solid Waste during emergencies, as described in Section 11. Under this Section, CONTRACTOR may be requested to perform work in other COUNTY Franchise areas, Garbage Disposal Districts, cities, or Counties. Likewise, other waste haulers may be requested to provide Solid Waste services within this Service Area.

3. Food Waste

This CONTRACT is not exclusive in regards to Collection, transportation and Diversion of Food Waste. This exclusion also applies to Food Waste discarded in Carts by Commercial Franchise customers. Commencing upon the Commencement Date, CONTRACTOR shall Collect Food Waste discarded with Refuse.

At any time after the Commencement Date, in its sole discretion, COUNTY may do either of the following with respect to Collection, transportation, and Diversion of Food Waste that is discarded separately from Refuse:

- Renegotiate a change to this CONTRACT or enter a separate contract with the CONTRACTOR; or
- Enter a contract with another Person.

D. Definition of Rights

In accordance with PRC Section 49523, based on the mutually satisfactory terms of providing Task 1 Services set forth in this CONTRACT and receipt of compensation therefore, CONTRACTOR shall cease providing Contract Services on the Expiration Date even if that Expiration Date should occur before the expiration of the period described in PRC Section 49520. This CONTRACT and acknowledgments in this CONTRACT do not foreclose COUNTY from re-procuring contracts for MSW Management Services, including from CONTRACTOR, after termination of this CONTRACT, by nonexclusive, partially exclusive, or wholly exclusive franchise, contract, license, permit or otherwise, with or without competitive bidding.

E. No Longer Used

F. Privacy (Contract Services)

1. General

CONTRACTOR shall strictly observe and protect the rights of privacy of Customers and Occupants. CONTRACTOR shall not reveal to a Person other than COUNTY any information identifying individual Customers and Occupants or the composition or contents of a Customer's Solid Waste to any Person unless under Section 9 or upon the authority of law or upon valid authorization of the Customer. This provision may not be construed to excuse CONTRACTOR from its obligations to assist COUNTY in the preparation of Solid Waste characterization studies or waste stream analyses, keeping Records, making Reports, or assisting COUNTY on meeting Federal, State, and local requirements.

2. Mailing Lists

CONTRACTOR shall not market or distribute mailing lists with the names and addresses of Customers and Occupants.

3. Privacy Rights Cumulative

CONTRACTOR'S obligations in this Section are in addition to any other privacy rights accorded Customers and Occupants under Applicable Law.

G. Ownership of Solid Waste

This CONTRACT does not purport to grant CONTRACTOR ownership over Solid Waste. The right to possession or ownership of Solid Waste placed at the Set-Out Site for Collection, including Green Waste, Recyclables, and Abandoned Waste, will be determined in accordance with existing law and is not affected by this CONTRACT. COUNTY acknowledges that it has no ownership rights in Solid Waste and that CONTRACTOR may provide for transfer of ownership in the Terms and Conditions.

SECTION 2 - TERM OF CONTRACT

A. Term of Contract Services

This CONTRACT is effective and binding on the Execution Date. It expires on the Expiration Date. Certain Performance Obligations survive expiration or termination of this Contract under subsection B below.

"Commencement Date" is August 13, 2018.

"Term" is the period beginning on the Execution Date and ending on the Expiration Date.

"Execution Date" is the date both COUNTY and CONTRACTOR mutually sign this CONTRACT.

"Expiration Date" is any of the following days, as may be extended described in the following subsection A1 of this Section:

- June 30, 2025; or
- As earlier date that the Contract terminates in accordance with Part 6D of Exhibit 5.

1. Extensions of the CONTRACT Term

Director shall have the sole option to extend the initial Term of this CONTRACT under the following subsections A2, A3, and A4.

2. Two, 18-Month Extensions

Director may, in his sole discretion, extend the Term of this CONTRACT for up to two additional 18-month periods.

3. Six, 1-Month Extensions

Director may, extend the Term of this CONTRACT up to six times, each time in an increment of one to six months for a total of no more than six months. For example, the Director may first extend the Term for three months, subsequently extend it for two more months, and lastly extend it for one more month.

4. Contract Extension Cumulative

The contract extensions are cumulative and may be exercised in any order. For example, after the end of the initial Term, Director may issue two 2-year extensions, one 3-month extension, followed by one 1-month extensions.

5. Transition to Next Waste Hauler

Certain obligations of CONTRACTOR survive the termination of this CONTRACT as provided under subsection B6 below.

6. Notification to CONTRACTOR

Director will Notify CONTRACTOR of the intent to extend or not extend this CONTRACT no later than the following:

- 90 calendar days before an 18-month extension begins
- 10 calendar days before a 30-day extension begins

B. Obligations Upon Expiration or Termination of CONTRACT

The following provisions will survive the expiration or termination of this CONTRACT:

1. Acknowledgements

All acknowledgments, including those in the following Sections:

- Item D of Section 1 (inapplicability of PRC 49520)
- Item C of Section 2 (no recovery of undepreciated asset value)
- Item A of Section 3 (no COUNTY responsibility for supervising or performing Task 1 Services)
- Item A of Section 9 (Record maintenance)
- Part 10 of Exhibit 5 (interpretation of this CONTRACT)

2. Representations and Warranties

All representations and warranties, including those made in accordance with the following Sections:

- Part 10 of Exhibit 5 with respect to review of this CONTRACT
- Item B of Section 14, Authority to Execute
- Attachment 5-9H, CONTRACTOR'S Representations and Warranties

3. Indemnities

All Indemnities.

4. Payments

All obligations to pay any due and payable monetary amounts or requests for those amounts, including:

- Payment of Transfer Deposits and Transfer Costs

- Damages under Item D of Section 12
- Payment of County Service Fees under Exhibit 3A2
- Refund due to Customers that pay Customer Service Fees in advance of Customer Service

5. Records and Reports

All obligations to maintain and submit Records and Reports, including:

- The final Annual Report
- Information with respect to Solid Waste Facilities
- Copies of certificates of insurance or other evidence of coverage
- Records of Disposal
- Notice of Destruction of Records of Disposal
- Inspection and audit
- Records of Abandoned Waste Collection including supporting documentation

6. Provisions Surviving Expiration Date

Any other provisions of this CONTRACT and rights and obligations of the Parties stated to survive the Expiration Date, including:

- This subsection B6 (cooperation during transition; removal of Carts), and
- Subsection C (no recovery of undepreciated asset value).

a. *Cooperation During Transition*

If CONTRACTOR is not awarded a new CONTRACT to allow CONTRACTOR to continue to provide MSW Management Services substantially similar to Contract Services in this Service Area after the expiration or termination of this CONTRACT, CONTRACTOR shall cooperate fully with Director and the succeeding contractor, licensee, permittee, or other provider of MSW Management Services to assure a smooth, efficient, orderly, timely, and effective transition.

b. *Removal of Carts*

With respect to Task 1 Services, CONTRACTOR shall not remove a Container from any Premises until the earlier of:

- The date any replacement Containers are provided to the Customer by succeeding contractor, or
- 2 weeks after the Expiration Date.

7. Container Purchase Option

COUNTY may purchase Containers as specified in Item D11 of Exhibit 3A1.

C. Undepreciated Assets

If any of CONTRACTOR'S Service Assets remain undepreciated upon the expiration or earlier termination by COUNTY of this CONTRACT, CONTRACTOR has no right to recover amounts equal to the undepreciated asset value from COUNTY or Customers, and neither COUNTY nor Customers are obligated to compensate CONTRACTOR for any undepreciated asset value.

CONTRACTOR acknowledges that when exercising its option to extend the Expiration Date, COUNTY need not consider whether any Service Assets are not fully depreciated as of the Expiration Date, and that CONTRACTOR invested in and depreciated those Service Assets in CONTRACTOR'S sole discretion.

SECTION 3 - SCOPE OF SERVICES AND SPECIFICATIONS (Contract Services)

A. Prescribed Scope

1. Task 1 Services

With respect to Task 1 Services, CONTRACTOR shall arrange to provide services to Premises in the Service Area in accordance with Exhibit 3A1 to both the following:

- Any Person in the Service Area who was receiving service immediately prior to the Commencement Date from Consolidated Disposal Services, LLC under a previous contract with COUNTY until August 12, 2018, and
- Any Person who request Task 1 Services.

2. Task 2 Services

With respect to Task 2 Services, CONTRACTOR shall provide services in the Service Area to Director in accordance with Exhibit 3A2.

3. Additional Contract Services Requirements

With respect to additional Contract Services, CONTRACTOR shall provide services in the Service Area to Director in accordance with Exhibit 3A3.

4. General

Contract Services include providing Goods, Services, and Property necessary to meet Performance Obligations, including:

- Labor and supervision;
- Software and hardware, including Records of Customer subscription and complaints, billing, and routing
- Leases; subleases; installment purchase agreements, including with respect to Vehicles and Carts,
- Equipment, including Vehicles, Carts, or other Containers (such as for special events);
- Supplies;
- Insurance, bonds, or other performance security if the insurer, surety, or another provider is an Affiliate or a captive of CONTRACTOR or any Affiliate;
- Maintenance and Office-administration facilities, and their contents,
- Legal, risk management, general, and administrative services.

CONTRACTOR must provide Contract Services in accordance with Service Specifications and Service Standards. Nevertheless, CONTRACTOR has the

freedom and discretion to determine the means, manner, or method of providing Contract Services. CONTRACTOR acknowledges that in entering into this CONTRACT, COUNTY is not responsible for supervising CONTRACTOR or for performance of any Contract Services. CONTRACTOR is responsible for choosing the Solid Waste Facilities, unless otherwise directed by COUNTY. In addition, COUNTY is not the owner or titleholder of any material Collected, transported, Disposed, or otherwise handled by CONTRACTOR.

Any work performed outside the Performance Specifications without Director's prior written approval will be deemed to be a gratuitous effort by CONTRACTOR. CONTRACTOR shall have no claim against COUNTY for any consequential or related liabilities.

B. Change in Scope of Services

1. Task 1

Director may change the scope of Task 1 Services and Service Standards in accordance with Part 9 of Exhibit 5, subject to any adjustment in the Customer Service Fees in accordance with Item A of Section 7.

2. Task 2

Director may change the scope of Task 2 Services and Service Standards in accordance with Part 9 of Exhibit 5, subject to any adjustment in COUNTY Service Fees in accordance with Attachment 7-3 Task 2 Service Fees.

C. No Longer Used

D. CONTRACTOR Documentation (Contract Services)

1. CONTRACTOR'S Compliance with CONTRACTOR Documentation

CONTRACTOR shall provide Task 1 and Task 2 Services in compliance with the CONTRACTOR Documentation attached as Exhibit 3D.

2. Changes in CONTRACTOR Documentation

a. *Notice to Director*

CONTRACTOR shall give Director prompt Notice of any changes in CONTRACTOR Documentation listed in Item A of Exhibit 3D CONTRACTOR Documentation, after the Execution Date. CONTRACTOR shall follow Notice procedure in Part 9F of Exhibit 5. Director's receipt of those changes will be evidenced by the following acknowledgment, appended in substantially this form to the changed CONTRACTOR Documentation:

From: Director Designee
Sent: Tuesday, May 09, 2017 4:55 PM
To: waste hauler
Cc: Business Relations and Contracts Division
Subject: Service Area Name - Acknowledgement of Notice

Acknowledgment: CONTRACTOR has submitted the attached CONTRACTOR Documentation.

Director Designee
Senior Civil Engineer
Los Angeles County Public Works
Office: (626) 458-3573

b. Director Consent.

CONTRACTOR shall submit to Director for review and consent any changes occurring in CONTRACTOR Documentation listed in Item B of Exhibit 3D CONTRACTOR Documentation, after the Execution Date. CONTRACTOR shall follow Notice procedure in Part 9F of Exhibit 5. Director's approval will be evidenced by the following acknowledgment, appended in substantially the following form to the changed CONTRACTOR Documentation:

From: Director Designee
Sent: Tuesday, May 09, 2017 4:55 PM
To: waste hauler
Cc: Business Relations and Contracts Division
Subject: Service Area Name - Acknowledgement of Consent

Acknowledgment: I have reviewed and approved the attached CONTRACTOR Documentation

Director Designee
Senior Civil Engineer
Los Angeles County Public Works
Office: (626) 458-3573

SECTION 4 - SERVICE STANDARDS

A. Public Health and Safety; Nuisances (Contract Services)

1. Litter

CONTRACTOR shall immediately clean up all litter it caused. If CONTRACTOR services an over-filled Container where the lid cannot be closed, any litter must be cleaned.

When Collecting any Bulky Item or Abandoned Waste, CONTRACTOR shall also clean up all litter within a 3-foot radius of the site from which CONTRACTOR Collected the Bulky Item or Abandoned Waste. CONTRACTOR shall ensure that each Vehicle is properly staffed and equipped for this purpose.

2. Spills

CONTRACTOR shall enclose or cover Solid Waste that it transports in Vehicles, debris boxes, hoppers, compactors, or any other containers. CONTRACTOR shall prevent Solid Waste from escaping, dropping, spilling, leaking, blowing, sifting, falling, or scattering from Vehicles (Spills) during Collection and transportation. CONTRACTOR shall not transfer loads from one Vehicle to another Vehicle unless necessitated by mechanical failure or accidental damage to a Vehicle. CONTRACTOR shall immediately clean up any Spills on any alley, street, or public place.

3. Leaking

CONTRACTOR shall prevent oil, hydraulic fluid, paint, or other liquid from leaking from its Vehicles. CONTRACTOR shall ensure that each Vehicle carries petroleum absorbent agents and other appropriate cleaning agents and if any liquid leaks from a Vehicle, CONTRACTOR shall immediately cover, treat, or remove the liquid materials from the ground, as necessary, and apply the necessary cleaning agent to minimize the adverse impact of the liquid materials.

4. Noise

CONTRACTOR shall conduct Collection as quietly as possible, in compliance with noise levels prescribed by Applicable Law, including County Code Section 12.08.520-Refuse Collection Vehicles. CONTRACTOR shall cause the least possible obstruction and inconvenience to public traffic or disruption to the peace and quiet of the Service Area.

B. Private Property (Task 1 Services)

CONTRACTOR shall obtain property owner consent to enter private driveways, alleys, streets, and parking lots in cases such as:

1. Private Property

a. *Acknowledgements*

CONTRACTOR acknowledges the following: Although there may be an implied waiver to access the front of Premises, a written consent may be advisable to access a side or rear yard. Additionally, private streets and driveways may not meet COUNTY's design standards and may not adequately withstand the weight of a Collection Vehicle.

b. *Damage to Pavement: Waiver*

If CONTRACTOR operates Vehicles on private property, following Director approval, CONTRACTOR may require the property owner to allow CONTRACTOR'S entry and waive liability for CONTRACTOR'S damage to driveways or other pavement, in a form satisfactory to Director. CONTRACTOR is not obligated to require a waiver. A waiver will not relieve CONTRACTOR of its obligation to repair or replace damaged pavements if it caused the damage by its negligent or willful acts or omissions under Part 9C of Exhibit 5.

c. *Personal Injury: Indemnity*

If CONTRACTOR enters private property whether in a Vehicle or by foot (for example to provide roll-out service), following Director approval, CONTRACTOR may require the property owner to hold harmless and indemnify CONTRACTOR in form satisfactory to Director. In that event, CONTRACTOR shall also require the property owner to hold harmless and indemnify COUNTY.

d. *CONTRACTOR Indemnifies COUNTY*

Despite receiving COUNTY approval, CONTRACTOR shall indemnify and hold COUNTY harmless from liabilities related to entering Customers' Premises, whether CONTRACTOR acts in compliance or noncompliance with this Contract. This indemnification is in addition to CONTRACTOR'S other Indemnifications.

2. Single-Pass Collection

If Customers request single-pass Collection (commingling of Refuse, Recyclables, and Green Waste) on private alleys, streets, and parking lots,

CONTRACTOR shall submit a request to Director in accordance with Item M of Section 4, Single-Pass Collection.

C. Non-Collection (Contract Services)

CONTRACTOR is not obligated to Collect in any of the following events:

1. Unpermitted Waste

CONTRACTOR observes the presence of Unpermitted Waste at the Set-Out Site other than any Unpermitted Waste that CONTRACTOR Collects as Bulky Items;

2. Unsafe Condition

CONTRACTOR observes an unsafe condition at the Set-Out Site.

3. Not Bagged or Bundled

Solid Waste not placed in a Container, bags or bundles. Bulky Items do not need to be placed in a Container, bag, or bundle.

4. Not At Set-Out Site

A Container or a Bulky Item that is not placed at the Set-Out Site, except if a Customer has Roll-Out Service.

5. Exceed Weight Limitations

A Container exceeds any weight limitations described in Terms and Conditions.

6. Delinquent Payment

The Customer has not timely paid CONTRACTOR'S invoice for additional Task 1 Services in accordance with to Item B7 of Section 7. One week prior to removing any extra Container for nonpayment of additional Customer Service Fees, CONTRACTOR shall also leave a notice for Occupants on a Container and call, e-mail or text Customer stating the deadline for payment.

7. Inaccessible Premises

The Premises are not accessible to Vehicles.

8. Contamination

a. *Recyclables Containers*

Refuse, Green Waste, or Manure in a Recyclables Container.

b. *Green Waste Containers*

Refuse, Recyclables, or Manure in a Green Waste Container unless Manure is specifically allowed.

c. *Refuse Containers*

Manure in a Refuse Container.

d. *Manure Containers*

Refuse, Recyclables, or Green Waste in a Manure Container unless Green Waste is specifically allowed.

9. Unscheduled

Unscheduled excess Refuse, Green Waste, Bulky Items, and E-waste in areas requiring advanced scheduling for collection under Exhibit 3A1. CONTRACTOR shall call, email, or text Occupant by next Service Day to:

- Notify of the non-collection,
- Educate and explain why waste was not Collected, and
- Schedule the Collection.

If CONTRACTOR does not Collect Occupant's discarded Solid Waste, it shall complete a non-Collection notice and leave it securely attached to Occupant's Container or Bulky Items unless it is unsafe to do so. CONTRACTOR will use the form of non-Collection notice approved by Director in CONTRACTOR Documentation. The form must describe all the following:

- The reason CONTRACTOR did not Collect Occupant's Solid Waste,
- How the Customer can correct the problem, and
- How the Customer can contact CONTRACTOR.

Additionally, if the Occupant of the serviced Premises has signed up for electronic messages, such as the Smart-eClub, CONTRACTOR shall send a text or e-mail to the Occupant.

CONTRACTOR shall Collect the Customer's Solid Waste without additional cost to the Customer at the following times:

- **Same day:** no later than 6 p.m. on the day CONTRACTOR left the Non-Collection notice, if the Customer notifies CONTRACTOR before 12 p.m. that same day, or
- **Next day:** on the next day, if the Customer notifies CONTRACTOR after 12 p.m. that same day.

D. **Nondiscrimination**

CONTRACTOR shall comply with Subchapter VII of the Civil Rights Act of 1964, 42 U.S.C. Section 2000e-2000e(17). CONTRACTOR shall not exclude any Customer from receiving Contract Services on the grounds of race, creed, color, sex, gender, national origin, ancestry, religion, age, physical or mental disability, marital status, or political affiliation. It shall not exclude them from participating in, deny them the benefits of, or otherwise subject them to discrimination under this CONTRACT or under any project, program, or activity supported by this CONTRACT.

E. **CONTRACTOR Waste Reduction Practices (Contract Services)**

Consistent with the Board of Supervisors' policy to reduce the amount of Solid Waste Disposed in landfills within COUNTY, CONTRACTOR shall use best efforts to practice waste reduction and implement procurement policies in providing Contract Services, including maintaining Records. In written correspondence with Customers and Director, CONTRACTOR shall use recycled paper that is labeled to indicate its recycled content.

CONTRACTOR shall offer Customers the option to go paperless by joining the Smart e-Club in Item C2 of Section 6.

F. **Customer Correspondence and Other Materials (Task 1 Service)**

CONTRACTOR shall submit to Director for approval, written materials CONTRACTOR intends to distribute to Customers at least eight County Business Days before printing, texting, e-mailing, or mailing the materials.

At Director's request CONTRACTOR shall distribute written information to its Customers and Occupants by including it within CONTRACTOR's mailings or by separate electronic distribution.

G. **Publicity and News Media Relations**

1. **Publicity**

Unless otherwise required by subsection F or subsection G.2, CONTRACTOR and its Affiliates, employees, consultants, agents, or subcontractors may, without Director consent, publicize its Contract Services or indicate in its proposals and sales materials that it has been awarded this

CONTRACT to provide Contract Services, if CONTRACTOR develops that publicity, proposals, or sales materials in a professional manner.

Neither CONTRACTOR nor any of its Affiliates, employees, consultants, agents, or Subcontractors may publish or disseminate commercial advertisements, news or press releases, opinions or feature articles using the name of COUNTY without the prior written consent of COUNTY'S Chief Executive Officer and County Counsel.

2. News Media Relations; Trade Journal Articles

CONTRACTOR shall notify Director by telephone followed by e-mail of all requests for news media interviews related to the Contract Services (and not other communities) within 24 hours of receiving the request. Before responding to requests involving matters other than the Collection programs and scope of Contract Services, CONTRACTOR shall discuss CONTRACTOR'S proposed response with Director.

CONTRACTOR shall submit copies of CONTRACTOR'S draft news releases or proposed trade journal articles related to Contract Services to Director for prior review and approval at least four County Business Days in advance of release.

CONTRACTOR shall give Director copies of media interviews and news releases related to Contract Services within four County Business Days of their occurrence.

H. Responsiveness to County (Contract Services)

CONTRACTOR shall meet the following standards:

1. Normal

Respond to COUNTY communications such as telephone messages, text messages, and e-mails no later than the next COUNTY Business Day. Acknowledge, at a minimum, that the CONTRACTOR has received the communication and provide an estimated time for a full response if the communication's issue cannot be immediately resolved.

2. Special Events

Respond to telephone message within one hour during special events, such as Mulch and Compost Giveaway Events and Annual Cleanup Events.

3. Emergency Telephone Messages

Respond to any telephone message within one hour in cases of emergencies as required under Item J1 of Section 4.

4. Written Correspondence

Respond to written correspondence from Director within one week of receipt.

5. Meetings

Meet with Director during Director's Office Hours within one week of Director's oral or written request at Director's offices or other location requested by Director.

I. No Commingling of Solid Waste

1. No Commingling Between Areas (Contract Services)

CONTRACTOR may not commingle, in its Vehicles or otherwise, any Solid Waste that it Collects with the Service Area with any other Solid Waste that it Collects outside the Service Area in cities or other unincorporated areas, without prior written consent of Director.

For example, Director may allow Food Waste to be Collected from multiple jurisdictions to make Collection routes more efficient and therefore more cost effective.

Director may require documentation such as records of Customers, including Container capacities, in cities and in the Service Area, respectively. CONTRACTOR shall maintain Records with respect to Solid Waste collected in the Service Area separately from records with respect to Solid Waste collected outside the Service Area, including its weight.

2. No Commingling of Different Materials (Task 1 Service)

CONTRACTOR may not commingle, in its Vehicles or otherwise, any Solid Waste that it Collects with any other Solid Waste that it Collects, without prior written consent of Director, as detailed in Item M of this Section. Additional requirements are in Item G2 of Exhibit 3A1.

J. Key Personnel (Contract Services)

CONTRACTOR acknowledges that it identified certain personnel and described their professional experience and qualifications in the proposal it submitted to Director about the procurement of this CONTRACT, and that COUNTY awarded this CONTRACT to CONTRACTOR based in part on those individuals' experience and qualifications. CONTRACTOR shall identify those personnel (Key Personnel) in CONTRACTOR Documentation, Exhibit 3D.

CONTRACTOR shall notify Director immediately of changes or upcoming changes in Key Personnel, including the professional experience and qualifications of the individual CONTRACTOR proposes to serve in place of a departing Key Personnel. Director may request CONTRACTOR to propose an alternative individual to serve in the position of the departing Key Personnel.

1. Emergency Telephone Number

CONTRACTOR shall maintain a local emergency telephone number disclosed to Director for use by Director outside CONTRACTOR Office Hours. CONTRACTOR shall make a representative available at the emergency number outside CONTRACTOR Office Hours who will return any emergency call as soon as possible and in any event within one hour.

2. Lead Person

CONTRACTOR shall assign a lead person(s), such as a route supervisor, to this Service Area. The lead person shall be responsible for ensuring that CONTRACTOR meets Performance Obligations. They shall spend as much time as possible in the Service Area. They shall act as a liaison between field crew and Director.

K. Uniforms (Contracts)

CONTRACTOR shall require its field employees to wear uniforms and prohibit them from removing any portions of their uniforms while providing Contract Services. Uniforms must meet the following specifications:

- Bear the CONTRACTOR's name, or other name approved by Director, for example, a DBA instead of a corporate name, and
- CONTRACTOR'S logo.

L. Confidentiality (Contracts)

CONTRACTOR shall maintain the confidentiality of all records obtained from Director under this CONTRACT in accordance with all Applicable Law. CONTRACTOR shall inform all its officers, employees, agents, and Subcontractors providing Contract Services of this confidentiality obligation. CONTRACTOR acknowledges that these records may be subject to a Public Records Request made to COUNTY.

M. Single-Pass Collection (Task 1)

CONTRACTOR shall obtain Director's approval prior to implementing single-pass service. "Single-pass service" means that Customers may commingle and discard Refuse, Recyclables, and Green Waste, and CONTRACTOR may Collect them in the same Container.

After Collection, CONTRACTOR must separate those commingled Solid Waste materials at a materials recovery facility, and Divert them. Director may approve Disposal of Recyclables and Green Waste based upon the number of Customers. CONTRACTOR shall maintain weight Records of commingled Solid Waste separately from weight Records of source-separated Solid Waste.

Customers may request single-pass service on private alleys, streets, and parking lots. CONTRACTOR may request single-pass service on extremely narrow or steep roads and other places where it is difficult to Collect with Collection Vehicles used elsewhere in the Service Area. Requests must include the following:

- Proposed addresses.
- Written consent from most Customers affected by the single-pass.
- Notification to Customers residing on the Premises being serviced.
- Single-type (Refuse) Containers without Recycling and Green Waste Containers.

SECTION 5 - ADDITIONAL CONTRACT PROVISIONS

Exhibit 5 contains additional CONTRACT provisions that are incorporated by reference into the CONTRACT. Exhibit 5 includes the following parts:

Part 3 General CONTRACT Requirements

Part 4 Indemnifications and Insurance

Part 6 Debarment Breaches and Defaults; Suspensions; Termination

Part 8 Transfer of CONTRACT

Part 9 General Provisions

Part 10 Definitions and Interpretations of CONTRACT

Part 11 Compliance with Laws and Regulations

Part 12 Labor-Related Provisions Required in County Contracts

SECTION 6 - CUSTOMER SERVICE (Task 1 Services)

A. Facilities

CONTRACTOR shall maintain both the following:

- A Vehicle maintenance yard, and
- Office at the address provided in CONTRACTOR Documentation.

CONTRACTOR may change the address by notifying Director in accordance with Item A6 of Exhibit 3D.

B. Telephone Service

CONTRACTOR shall maintain a toll-free telephone number and meet the following criteria:

1. Office Hours

CONTRACTOR shall provide a customer service representative to personally answer all calls to the toll-free number during CONTRACTOR Office Hours, including calls from Director, Customers, Occupants, and the public.

2. After Hours

CONTRACTOR shall provide an answering machine to answer all calls to the toll-free number outside of CONTRACTOR Office Hours that allows callers to leave messages, such as reporting missed pick-ups and other complaints. CONTRACTOR shall further comply with County Code Section 20.72.160.

3. On Hold Messaging

CONTRACTOR shall use Reasonable Business Efforts to broadcast public education messages while Customers are waiting on hold to talk to a customer service representative.

4. Telephone Tree

CONTRACTOR shall require no more than two recorded options on a telephone tree before the caller speaks to a live customer service representative (for example, English/Spanish and residential/commercial service choices).

5. Answer Speed

CONTRACTOR shall use Reasonable Business Efforts to answer the telephone within four rings. CONTRACTOR shall answer 90 percent of all calls within the first 4 rings.

CONTRACTOR shall not leave the Customer on hold for more than ten minutes.

If Director determines that CONTRACTOR does not meet these Service Standards, Director may require that CONTRACTOR install additional telephone lines, hire additional customer service representatives, and make other customer service improvements without increasing Service Fees. Their determination will be based on whether the CONTRACTOR answers calls:

- Within five rings, based on at least three calls within one week, or
- 10 calls within one month.

6. Bilingual

CONTRACTOR shall respond to Customers and Occupants in English or Spanish as requested by the Customer or Occupant.

7. Knowledgeable Staff

CONTRACTOR shall provide customer service representatives with a knowledge of basic services in the CONTRACT. A supervisor with extensive CONTRACT knowledge is to be available to respond to questions or concerns by callers.

A representative answering a regional or nation-wide hotline with no CONTRACT specific training is not acceptable. Also, calling someone back after researching the correct answer is acceptable but providing the wrong information due to a lack of adequate training is not acceptable.

C. Paperless/Electronic Information and Services

1. Website

CONTRACTOR shall develop and maintain a website that includes the following information and Service options:

a. Service Information

Information such as Terms and Conditions form or service information, service brochures, newsletters, FAQ's, Holiday schedules, holiday tree pick-up information, service changes, invoice

explanations, allowable and forbidden discards, list of recyclable materials, educational and outreach materials, notifications, alerts, and other information requested by Director.

b. *Bill Payment*

The ability for Customers to review and pay their bills for Additional Customer Services under Item B3 of Section 7, if they subscribe to Smart e-Club.

c. *Service Requests*

Requests for service collection that is not regularly scheduled, including on-call bulky waste collection, requests for extra pickups, and service cancellations.

d. *Contact Us*

CONTRACTOR's contact information where Customers can register complaints and follow-up on complaint resolution.

e. *Link*

Link to Director's website, CleanLA.com.

2. Smart-eClub

To reduce paper waste and reach more readers, CONTRACTOR shall offer both the owners and occupants of serviced Premises the option to join the Smart e-Club. CONTRACTOR shall offer Customers the following Smart e-Club options:

- Receiving service information described in preceding Item C1a electronically, subsequently switching back to paper;
- Electronic billing under preceding Item C1b;
- Making service requests under preceding Item C1c; and
- Contacting CONTRACTOR under preceding Item C1d.

CONTRACTOR shall give all educational messages and the template for service messages to Director for approval prior to sending to Customers. Upon Director's request, CONTRACTOR shall send messages provided by Director.

3. E-mail Address

CONTRACTOR shall maintain an e-mail address for use by Customers and Occupants.

D. Responses to Customer Complaints and Other Correspondence

1. Resolution of Complaints

a. *Call/E-mail for Service*

CONTRACTOR shall maintain an e-mail address under preceding subsection C3 and telephone service under subsection B of this Section.

A call or e-mail from a Customer or Occupant to request a service or report an issue, such as a damaged container, is not considered a complaint.

b. *First Complaint*

CONTRACTOR shall address all Customer and Occupant complaints immediately and resolve them by the end of the next Service Day following Customer or Occupant contact or any reasonable time agreed upon between Customer or Occupant and CONTRACTOR. A Customer or Occupant should not have to call or e-mail to complain on the same issue because CONTRACTOR did not resolve it as previously committed by CONTRACTOR, such as a damaged container was not repaired or replaced as committed.

c. *Second and Subsequent Complaints*

A Customer or Occupant should never have to call or e-mail to complain a second time on the same issue because CONTRACTOR did not resolve it as previously committed by CONTRACTOR such as a damaged container was not repaired or replaced and the Customer or Occupant previously called or e-mailed to complain.

2. Communications Log

CONTRACTOR shall enter, log, and maintain Records of all communications and their resolution, in computerized format and in compliance with County Code Section 20.72.160. CONTRACTOR shall maintain that log. CONTRACTOR shall submit the log for the applicable quarter to Director with CONTRACTOR'S Quarterly Report under Item A2 of Section 10.

3. Missed Collections

If Director, a Customer, or an Occupant notifies CONTRACTOR that CONTRACTOR has not Collected an Occupant's Solid Waste and not met its Performance Obligation, CONTRACTOR shall Collect at no additional charge:

- No later than 6 p.m. on the day of service, if it receives the complaint by 12 p.m.; or
- On the next day, if the complaint is received after 12 p.m. on the day of service.

4. County's Reimbursement Costs

If COUNTY employees or their contractors spend more than either of the following times resolving Customer complaints, then CONTRACTOR shall reimburse COUNTY its Reimbursement Costs that COUNTY incurred to resolve the complaint:

- Two hours in the aggregate resolving complaints from any single Customer that the Customer states have previously been filed with CONTRACTOR, or
- More than one hour in any work week (Monday through Friday) resolving complaints from different Customers.

The invoice for Reimbursement Costs should include all the following information:

- The address of the Premises being serviced,
- Customer who complained,
- Nature of complaint,
- Amount of time spent,
- Costs, including hourly fees for employees, agents or contractors who addressed the complaints, and
- Expenses, including phone and postage costs.

E. Service Interruption

CONTRACTOR shall monitor the Department of Public Works Road Closure website (<http://dpw.lacounty.gov/roadclosures/>) for conditions that may cause service interruptions. CONTRACTOR shall not alter or interrupt its service schedule without Director consent.

CONTRACTOR shall alert all Customers and Occupants of any Director-approved interruption in service and when service will resume. CONTRACTOR may use any type of communication, including phone blast, e-mail blast, and text messaging. Examples of interruption include various reasons, such as road closures, extreme weather conditions, or breakdown of CONTRACTOR equipment.

F. Responsiveness to Customer

Respond to communications such as telephone messages, text messages, and e-mails to the source that made contact no later than the next business day. If CONTRACTOR is unable to directly address the issue, CONTRACTOR shall

respond with an acknowledgement to confirm receipt of message and indicate when the issue will be addressed.

Respond to United States Postal Service, Federal Express, or other courier provided correspondence from Customers or Occupants within one week of receipt.

G. Setting Up or Terminating Service

1. New Customers

- Obtain contact and service location information
- Explain services and charges
- Mail brochure
- Offer Bulky Item Collection

2. Terminating Service

- Offer Bulky Item Collection
- Explain what to do with Containers
- Explain refund procedure for any prepaid services

SECTION 7 - SERVICE FEES AND BILLING

Additional Customer Services means all Performance Obligations prescribed in Exhibit 3A1 and Exhibit 3A3 that require a Customer Surcharge, including the more than once per week Collection frequency in item B3, more than one 96-gallon Refuse Container, or a locking Recyclables Cart.

Basic Service means all Performance Obligations prescribed in Exhibit 3A1 and Exhibit 3A3, including the once per week Collection frequency in item B3 and the one 96-gallon Refuse, two 96-gallon Recyclables, and two 96-gallon Green Waste Containers in item D, that do not include any additional services.

Basic Service Fee means the monthly charges that CONTRACTOR bills a COUNTY for providing Collection with respect to Customer Services, without additional optional services.

County Service Fee means the fees that CONTRACTOR bills COUNTY for providing Collection with respect to County Services.

Customer Service Fee means the Basic Service Fee and Customer Surcharges in the Customer Service Fee Schedule, Attachment 7-2, Task 1 Service Fees.

Customer Surcharges means the amounts listed as "Surcharges" on the Service Fee Schedule, Attachment 7-2, Task 1 Service Fees.

Garbage Disposal Districts are structured so that property owners pay for their Basic Services on their property taxes. CONTRACTOR shall invoice COUNTY and not Customers for that portion of the Contract Services.

The CONTRACTOR's bid on form PW-2.1, Schedule of Prices in Attachment 7-5, specifies the flat monthly payment rate for which the CONTRACTOR has agreed to perform the Customer Services described and specified herein upon commencement of this CONTRACT. Said monthly payment rate shall be referred to hereinafter as the initial monthly payment rate and shall be based upon the Refuse Units of the Service Area at the time the CONTRACTOR submitted its bid. The initial monthly payment rate paid to the CONTRACTOR shall be fixed and shall be the basic rate of monthly compensation upon which all subsequent adjustments of compensation shall be computed.

A count by Director of the total number of refuse units, referred to hereinafter as Refuse Units, assigned to each parcel of real property (including, but not limited to, Residential, Commercial, and Industrial Establishments, and vacant parcels) in the Service Area based on land use codes as shown by the current records of the County Office of the Assessor will be the "Basic Unit Count" upon which all subsequent adjustments of compensation are computed.

The current Basic Unit Count (number of Refuse Units in the Service Area), is shown on Form PW-2, Schedule of Prices. During the life of this CONTRACT, a new Basic Unit

Count will be made of all Refuse Units in the District as of the first day of each July or within 20 days thereafter. If the new Basic Unit Count is not generated within the allocated timeframe, the existing Basic Unit Count from the previous contract year shall remain in full force and effect.

In making all Basic Unit Counts called for under these specifications, Director may rely on the Assessor's most current tax roll or other records, and the same are hereby agreed to be a true and correct reflection of the number of Refuse Units in the District as of the dates prescribed for computation.

Director will compute the monthly unit rate in the following manner: the initial monthly payment rate will be divided by the Basic Unit Count, thus establishing a monthly unit rate. This monthly unit rate shall prevail throughout the life of this CONTRACT, except as specifically provided for in this Exhibit 7. Computation described herein shall be carried to the fourth decimal place.

To determine the monthly payment rate for the second and each subsequent year of the contract, Director will multiply the current Basic Unit Count, as of July of the current year, by the monthly unit rate, thus establishing a new monthly payment rate which shall be paid monthly to the CONTRACTOR during the 12-month period beginning in September of the current year, for services performed beginning in August of the current year.

A. Customer Service Fees

CONTRACTOR shall charge Customers no more than the Customer Service Fees in Attachment 7-2, Task 1 Service Fees of Exhibit 7. Customer Service Fees are subject to a rate adjustment as specified in Item B of Exhibit 7.

1. Uniform Fees

CONTRACTOR shall charge the same, uniform Customer Service Fees for the same Task 1 Services listed in Attachment 7-2, Task 1 Service Fees of Exhibit 7. For example, one Customer should not be charged \$10 for roll-over service while another customer is charged \$8.

2. Surcharges

Surcharges will be added to the Basic Service Fee. See Attachment 7-2, Task 1 Service Fees of Exhibit 7.

a. *Billing Fees*

- 10 percent late fee
- \$25.00 for interruption of service
- \$25.00 fee on returned checks

b. *Extra Containers*

c. *Difficult to Service*

d. *Roll out Service*

(1) Non-Elderly or Non-Disabled

(2) Elderly or Disabled

CONTRACTOR shall provide this service, without additional charge to Customer, for Occupants who are Elderly or Disabled and certify to the CONTRACTOR that there is no able-bodied individual in the household who can roll-out Cart to the Set-Out Site.

e. *Additional Bulky Item Collection*

f. *Excessive Container Exchanges*

g. *Manure Service*

h. *Bear Resistant Carts*

i. *Recyclables Cart with Gravity Lock*

B. Customer Invoice and Payment

While Basic Services within a GDD that are included in a properties allotment are paid through the property tax and shall not be billed by CONTRACTOR to the Customer. Any additional surcharges as identified in Section 7A2 are to be billed to the Customer.

1. Invoice Content

CONTRACTOR shall include in its Customer invoice the following information:

a. *Contact Information*

CONTRACTOR's telephone number, Office address, website and e-mail address for Customer complaints and questions.

b. *Itemized Costs*

Itemize costs in accordance with services. CONTRACTOR shall not identify that portion of a Customer's invoice attributable to a Franchise Fee, if any.

c. Paperless Option

A message promoting its website-based invoicing and payment system on all paper invoices sent to Customers.

At Director's request, CONTRACTOR shall promptly submit a copy of a Customer's invoice to Director.

2. Frequency

CONTRACTOR shall invoice Cart Customers quarterly following the Calendar Year quarter and Dumpster Customers (if applicable) monthly, or an alternate frequency as approved by Director.

Customers are not to be billed to their Basic Services. For Method of Payment to COUNTY for these services, see Item J of Exhibit 3A1. However, surcharges for Task 1 Services are to be billed to customers quarterly, three months in advance. Bills shall be sent on or after the first day of the billing period. Payment in full is due no later than the last day of the first month. For example, bills that are sent on April 1 for the billing period of April, May, and June are due on April 30.

If Customer fails to pay bill in full, see Item B7 of this Section for actions to be taken.

3. Electronic Invoicing

To reduce paper waste, CONTRACTOR shall make available to all Customers an electronic invoicing system at no additional charge. CONTRACTOR shall ensure that the electronic invoicing and payment website conforms to industry-standard practices for electronic commerce security. CONTRACTOR must ensure that these Customers receive invoice inserts, such as newsletters either electronically or paper copies, as requested by Customer. Through CONTRACTOR'S website, Customers may request to cease paper invoices and receive all invoices through e-mail or access them on CONTRACTOR'S website.

4. Inserts

At Director's request, CONTRACTOR shall include a message and/or enclose with Customer's invoice all inserts prepared and provided by Director.

5. Electronic Payment

CONTRACTOR shall make available to all Customers an electronic payment system at no additional charge. This system will be website based and allow Customers to pay invoices through CONTRACTOR'S website, both one-time and reoccurring. CONTRACTOR must allow credit card payments and may include direct bank routing or other payment methods.

6. Refunds

CONTRACTOR shall refund any overcharges to a Customer (including advance payments for Task 1 Services that are subsequently canceled) within 30 days after collection thereof. CONTRACTOR shall pay the Customer interest on overcharges (other than advance payments for subsequently canceled services) with interest thereon at ten percent per annum from the date originally overcharged until the date refunded.

7. Late Payment

a. *Residential Customers (Quarterly Billing)*

Residential Customer payment of bills for Additional Customer Services are due to CONTRACTOR no later than the last day of the first month of the calendar quarter. The following are the required warning notices and maximum penalties for late payment. CONTRACTOR may be more lenient.

If payment is not received after 1.5 month, a reminder shall be sent to Residential Customer indicating missed payment, balance due, and warning of ten percent late fee. If payment is not received by the last day of the second month, the account will become delinquent and an additional ten percent fee may be added to the balance. If payment is not received after 2.5 months, a second reminder shall be sent to Residential Customer indicating missed payment, balance due including ten percent late fee, and warning of stopping service and Container removal. If payment is not received after three months, Additional Customer Services may be stopped. If payment is not received after 3.5 months, additional Task 1 Collection services may be interrupted and any extra Containers removed from the premises and a \$25 interruption fee may be charged upon returning Containers to Premises. CONTRACTOR is to abide by any trespassing laws while removing Containers.

Plain Language Table

Elapsed Time	Action
1st day of quarter	Bill sent to Residential Customer
1 month	Bill due to CONTRACTOR
1.5 months	Reminder sent with warning of late fee
2 months	Unpaid bill delinquent and ten percent late fee added
2.5 months	Reminder sent with warning of stop Additional Customer Services, Container removal, and interruption fee
3 months	Additional Customer Services stopped
3.5 months	Extra Containers removed, \$25 interruption fee

b. Commercial Customers (Monthly Billing)

Commercial Customer payment of bills for Additional Customer Services are due to CONTRACTOR no later than the last day of the month. The following are the required warning notices and maximum penalties for late payment. CONTRACTOR may be more lenient.

If payment is not received after 1.5 months, a reminder shall be sent to Commercial Customer indicating missed payment, balance due, and warning of ten percent late fee. If payment is not received by the last day of the second month, the account will become delinquent and an additional ten percent fee may be added to the balance. If payment is not received after 2.5 months, a second reminder shall be sent to Commercial Customer indicating missed payment, balance due including ten percent late fee, and warning of stopping Additional Customer Services and extra Container removal. If payment is not received after three months, Additional Customer Services may be stopped. If payment is not received after 3.5 months, Additional Customer Services may be interrupted and any extra Containers removed from the premises and a \$25 interruption fee may be charges upon returning Containers to Premises. CONTRACTOR is to abide by any trespassing laws while removing Containers.

Plain Language Table

Elapsed Time	Action
1st day of quarter	Bill sent to Commercial Customer
1 month	Bill due to CONTRACTOR
1.5 months	Reminder sent with warning of late fee
2 months	Unpaid bill delinquent and ten percent late fee added
2.5 months	Reminder sent with warning of stop Additional Customer Services, Container removal, and interruption fee
3 months	Additional Customer Services stopped
3.5 months	Extra Containers removed, \$25 interruption fee

a. Partial Payment

If Customers fails only to pay for surcharges for any or all special services in Item A2 of Section 7, those special services shall be stopped without affecting other services. For example, if a Customer has an extra Refuse Container but is not paying the fee for the Container, the extra Container should not be Collected but all other Task 1 Services shall be provided.

b. Returned Check Fee

A \$25 fee on returned checks (insufficient funds) may be charged to Customer.

C. County Service and Fees

1. County Service Fees and Maximum Contract Sum

COUNTY agrees, in consideration of satisfactory performance of Task 2 Services in Sections A and B of this exhibit, in strict accordance with the service specifications set forth herein, to the satisfaction of Director, to pay the CONTRACTOR County Service Fees at the fee specified in Attachment 7-3, Task 2 Service Fees of Exhibit 7 for Disposal that CONTRACTOR Collects, **not to exceed \$678,150.00** per Contract Year or a greater amount as the Board may approve. This is referred to as the "Maximum Contract Sum" for Task 2 Services.

a. *Abandoned Waste Not Commingled*

If CONTRACTOR does not commingle Abandoned Waste in the same Vehicle with other Refuse, and the facility weighs Abandoned Waste that CONTRACTOR delivers, CONTRACTOR shall report that weight to Director in the Monthly Report and keep copies of all weigh receipts. If a facility does *not* weigh those materials, CONTRACTOR shall calculate the weight of allocated Abandoned Waste in accordance with Cal Recycle weight conversion standards <http://www.calrecycle.ca.gov/LGCentral/Library/dsg/Apndxl.htm>, or other method satisfactory to Director.

b. *Abandoned Waste Commingled*

If CONTRACTOR *does* commingle Abandoned Waste in the same Vehicle as other Refuse, CONTRACTOR shall allocate the proportion of Abandoned Waste to other Refuse in a formula approved by Director, and weigh or calculate the weight of the Abandoned Waste as set forth in the preceding paragraph.

2. Special Fund Obligation

COUNTY will pay County Service Fees from COUNTY'S Road Fund or other sources. CONTRACTOR acknowledges that it will not be compensated for providing County Service under Task 2 Services from Customer Service Fees under Task 1 Services. Customers or Occupants do not pay County Service Fees.

3. Billing

CONTRACTOR shall bill COUNTY monthly for COUNTY Services performed during the preceding month by invoice (original and a copy) in a form satisfactory to Director. COUNTY will pay County Service Fees to the CONTRACTOR within 30 days of receipt and approval of a properly completed and undisputed invoice. If CONTRACTOR is certified by

Lennox Garba

COUNTY as a Local Small Business Enterprise, COUNTY will pay CONTRACTOR in accordance with Board of Supervisors Policy No. 3.035, Small Business Liaison and Prompt Payment Program.

The Itemized invoice shall contain a reference to the name of the Service Area and Environmental Programs Division, Residential Franchise/Garbage Disposal District Section. CONTRACTOR shall submit invoices to:

County of Los Angeles Department of Public Works
Attention Fiscal Division, Accounts Payable
P.O. Box 7508
Alhambra, CA 91802-7508

For weekly or daily Abandoned Waste Collection, CONTRACTOR shall bill COUNTY based on per incident, foot, day, or receptacle collection, as indicated in Attachment 7-3 Task 2 Service Fees of Exhibit 7. The rate shall be calculated as follows:

a. *Weekly Collection*

(1) *Expected Number of Incidents, Volume Up to Four Cubic Yards*

CONTRACTOR may request a fee equal to the expected number of incidents rate for four cubic yards of volume.

CONTRACTOR is required to record the location of each incident and submit with the monthly invoice. CONTRACTOR is not required to provide evidence of Abandoned Waste removal unless Director requests.

(2) *More Than Expected Number of Incidents*

CONTRACTOR may request a fee equal to the more than expected number of incidents rate.

CONTRACTOR is required to record the location of each incident and submit with the monthly invoice. CONTRACTOR shall take and submit photos of the waste to request a higher fee for that location. These special circumstances must be Itemized separately on the invoice.

(3) *More Than Four Cubic Yards*

CONTRACTOR may request a fee equal to the more than four cubic yards rate for a volume greater than four cubic yards.

CONTRACTOR is required to record the location of each incident and submit with the monthly invoice. CONTRACTOR

shall take and submit photos of the waste to request a higher fee for that location. These special circumstances must be Itemized separately on the invoice.

b. Hot Zone Daily Monitoring and Collection

(1) Monitoring All Hot Zone Locations

CONTRACTOR may request a fee equal to the Monitoring All Hot Zone Locations for every linear foot within the zone, each day. All Hot Zones refers to the original location indicated in CONTRACT and not any that are added after the Execution Date.

For example, for a \$1.00 rate for 500 feet, CONTRACTOR may request $\$1.00 \times 500 \times 22 \text{ days} = \$11,000$ per month. CONTRACTOR is not required to provide evidence of monitoring unless Director requests.

(2) Additional Hot Zone Monitoring

After the Execution Date, if Hot Zones are created or expanded greater than the length indicated in Item 16.A.2 of Exhibit 16, CONTRACTOR may request a fee equal to Monitoring Additional Hot Zones for the additional distance only.

CONTRACTOR is not required to provide evidence of monitoring unless Director requests.

(3) Waste Collection from All Hot Zone Locations

CONTRACTOR may request a fee equal to the Waste Collection from All Hot Zone Location with four cubic yards or less rate. All Hot Zones refers to the original locations indicated in CONTRACT and not any that are added after the Execution Date.

The four cubic yards volume refers to the total amount of waste at a single incident, not the total collected in all Hot Zones. For example, five piles of two cubic yards is billed at this rate and is not considered ten cubic yards. Waste separated by more than ten feet shall be considered a separate incident. CONTRACTOR is not required to provide evidence of Collection unless Director requests. CONTRACTOR is required to record the location of each incident and submit with the monthly invoice.

(4) **Additional Hot Zone Waste Collection**

After the Execution Date, if Hot Zones are created or expanded greater than the length indicated in Item 16.A.2 of Exhibit 16, CONTRACTOR may request a fee equal to the Additional Hot Zone Waste Collection with four cubic yards or less rate for the additional distance only.

The four cubic yards volume refers to the total amount of waste at a single incident, not the total collected in all Hot Zones. Waste separated by more than ten feet may be considered a separate incident. CONTRACTOR is not required to provide evidence of Collection unless Director requests. CONTRACTOR is required to record the location of each incident and submit with the monthly invoice.

(5) **Waste Collection with More Than Four Cubic Yards**

For any incident larger than four cubic yards, CONTRACTOR may request an extra fee equal to the Waste Collection With More Than four cubic yards rate. Waste separated by more than ten feet shall be considered a separate incident. CONTRACTOR shall take and submit photos of the waste to request a higher fee for that location. These special circumstances must be Itemized separately on the invoice.

c. Public Receptacles

CONTRACTOR may request a fee equal to the number of Collections made from Public Receptacles during the month, regardless if it is Refuse or Recyclables from a standard or solar powered compactor. CONTRACTOR is required to record the number of Collections and submit with the monthly invoice.

d. Homeless Encampments

(1) **Abandoned Homeless Encampments**

CONTRACTOR may request a fee equal to the number of Collections made during the cleanup on an abandoned homeless encampment during the month.

(2) **Occupied Homeless Encampments**

CONTRACTOR may request a fee equal to the number of each bag, box, or Dumpster Collections made each week at homeless encampments during the month.

4. Payment Exceeding Maximum Contract Sum

In no event shall the aggregate total amount of compensation paid to the CONTRACTOR exceed Maximum Contract Sum.

5. Request Work

The CONTRACTOR understands and agrees that only Director is authorized to request or order work under this CONTRACT. The CONTRACTOR acknowledges that the designated authorized representative is not authorized to request or order any work that would result in the CONTRACTOR earning an aggregate compensation more than this CONTRACT's Maximum Contract Sum.

6. Performing Work to Exceed Maximum Contract Sum

The CONTRACTOR shall not perform or accept work requests from the designated authorized representative or any other person that will cause the Maximum Contract Sum to be exceeded. CONTRACTOR shall monitor the balance of the Maximum Contract Sum. When the total of the CONTRACTOR's paid invoices, invoices pending payment, invoices yet to be submitted, and ordered services reaches 75 percent of the Maximum Contract Sum, the CONTRACTOR shall immediately notify the authorized representative in writing.

7. Budget Reduction

If the Board of Supervisors adopts a budget for any Fiscal Year that reduces the salaries or benefits paid to most COUNTY employees and imposes similar reductions with respect to COUNTY Contracts, COUNTY reserves the right to correspondingly reduce the following:

- The County Service Fees for that Fiscal Year and any subsequent Fiscal Year during the Term of this CONTRACT (including any extensions), and
- The Maximum Contract Sum.

Except as set forth in the preceding sentence, the CONTRACTOR shall continue to provide all the services set forth in this CONTRACT. Director's notice to the CONTRACTOR regarding said reduction in payment obligation shall be provided within 30 calendar days of the Board's approval of such actions.

8. Deductions

COUNTY may deduct from any payment due CONTRACTOR any incurred or anticipated County Reimbursement Costs, including legal fees and staff costs, associated with any investigation or enforcement proceeding brought by Cal/OSHA arising out of COUNTY Service.

9. No Payment Following Expiration/Suspension/Termination of CONTRACT

CONTRACTOR shall make no claim against COUNTY for payment of any money or reimbursement, of any kind whatsoever, for any County Service that CONTRACTOR provides after the expiration, suspension, or other termination of this CONTRACT. If CONTRACTOR receives any such payment, it shall immediately inform Director and repay all that payment to COUNTY. Payment by COUNTY for County Services rendered after expiration, suspension, or termination of this CONTRACT shall not constitute a waiver of COUNTY's right to recover such payment from CONTRACTOR. This provision shall survive the expiration, suspension, or termination of this CONTRACT.

10. Most Favored Public Entity

If the CONTRACTOR's prices decline, or should the CONTRACTOR, at any time during the term of this CONTRACT provides the same goods or services under similar quantity and delivery conditions to the State of California or any County, municipality, or district of the State at prices below those set forth in this CONTRACT, then such lower prices shall be immediately extended to the County.

11. Change in Service Area

It is understood that the monthly compensation to be paid to the CONTRACTOR may be increased in proportion to the enlargement of the boundaries of the Service Area or to expansion of the area to be served, and the monthly compensation may be decreased if the area to be served decreases such as diminution of the size of the Service Area. This also included a change in the number of public receptacles and a change in the number or length of Hot Zones.

12. Dissolution of Service Area

It is understood that in the event of the dissolution of the Service Area, this CONTRACT and all obligations of either of the parties thereto shall be at an end, whether such dissolution results from proceedings under the provisions of the act pursuant to which the Service Area was created, by operation of law, or resulting from municipal annexation or incorporation, except for record retention requirements.

13. Adjustment to County Service Fee

Throughout the Term of the CONTRACT, COUNTY may adjust the Service Fee in Attachment 7-3, Task 2 Service Fees of Exhibit 7, per the conditions set forth in Exhibit 7.

SECTION 8 - WASTE CHARACTERIZATION STUDY

A. Participate with County Study

CONTRACTOR shall cooperate with Director in conducting Solid Waste characterization studies and waste stream audits. Cooperation includes all the following:

- Diverting Collection Vehicles from their regular route to alternate locations;
- Emptying all Solid Waste from Collection Vehicles; and
- Providing Collection, transportation, and Disposal of Solid Waste remaining after the study or audit.

B. Perform Study

CONTRACTOR shall perform Solid Waste generation and Disposal characterization studies to assist County in compliance with State laws and goals. CONTRACTOR's study shall also include collecting data and preparing reports, as needed and as directed by Director, to determine weights and volumes of Solid Waste that is Collected and to characterize Solid Waste that is generated, Disposed, transformed, Diverted, or otherwise processed, by Customer type (such as Single-Family, Multi-Family, Commercial).

1. Methodology

CONTRACTOR shall follow all guidelines and sampling methodology established by CalRecycle when conducting the study.

2. Frequency

CONTRACTOR shall perform the required studies during the first Contract Year and every other year thereafter.

SECTION 9 - RECORDS

CONTRACTOR'S obligations and COUNTY'S rights in this Section survive the term.

A. Record Maintenance and Retention

1. All Records

CONTRACTOR shall prepare and maintain all Records in accordance with generally accepted auditing principles during the Term and for an additional period of not less than five years after the Expiration Date or any longer period required by Applicable Law.

2. Disposal Records

CONTRACTOR acknowledges:

a. *Claims*

That COUNTY may need to respond to claims under CERCLA or similar applicable laws with respect to Disposal of Solid Waste.

b. *Quantity*

COUNTY'S need to determine the quantity, location, and date of CONTRACTOR'S Disposal of Solid Waste.

Therefore, CONTRACTOR shall establish and maintain a protocol for the retention and preservation of those Records, for a period of five years after the Expiration Date or any longer period required by Applicable Law, which protocol will document where CONTRACTOR Disposed of Solid Waste that it Collected (whether landfilled, incinerated, composted, or otherwise processed or marketed).

3. Notification

CONTRACTOR shall give Notice to Director at least 30 days before destroying Records of Disposal at any time after the retention period referred to in Item A1 of Section 9.

B. County Custody

If Director has reason to believe that Records may be lost, discarded, or destroyed for any reason, Director may require that CONTRACTOR give COUNTY custody of any or all Records. Access to those Records will be granted to any Person duly authorized by CONTRACTOR. CONTRACTOR shall pay for storage cost.

C. Inspection and Review of Records

Upon five Service Days' notice by telephone or writing, or a lesser amount of time in the event of extraordinary circumstances, Director and/or its contractor may inspect, review (including using outside contractor), excerpt, transcribe, and copy all Records at CONTRACTOR'S Office during CONTRACTOR Office Hours. CONTRACTOR may maintain Records outside of COUNTY (1) if it promptly provides copies thereof to Director at Director's offices, (2) if Director, in its sole discretion, agrees to travel outside COUNTY and CONTRACTOR pays COUNTY's Reimbursement Costs.

In addition to travel costs, COUNTY will bear the expense of the review and of obtaining a copy of Records; however, within 30 days of Director Notice, CONTRACTOR shall reimburse COUNTY for COUNTY'S Reimbursement Cost of the expenses for the review if the review reveals a discrepancy of the lesser of three percent or \$2,500 between:

- The amount contained in the Records (e.g., the amount of Solid Waste Collected or Diverted), and
- Any representation or Report that CONTRACTOR made to COUNTY; Franchise Fee or other money paid to COUNTY; County Service Fees paid by COUNTY, or information that CONTRACTOR submitted to Director.

Director may give Notice to CONTRACTOR identifying any discrepancy.

CONTRACTOR shall pay any discrepant shortfall in Franchise Fee or other payments due COUNTY, or excess of County Service Fees, upon Director demand, including fees and charges for the late payment of Franchise Fees. Failure to make those payments will constitute a CONTRACTOR Default in accordance with Part 6 of Exhibit 5. In lieu of payment, Director in its sole discretion may (1) deduct that shortfall from amounts that COUNTY owes CONTRACTOR under this CONTRACT, other contracts, or any other obligation, or (2) draw that shortfall from the performance bond, letter of credit, certificate of deposit, or other form of performance assurance provided by CONTRACTOR in accordance with Section 16.

COUNTY will pay any discrepant shortfall in County Service Fees due CONTRACTOR up to COUNTY'S maximum obligation for County Service Fees appropriated by COUNTY for purpose of this CONTRACT.

D. Copies of Audits

If anyone, including Federal or State auditors and auditors or accountants employed by CONTRACTOR or others, conducts an audit of CONTRACTOR specifically regarding this CONTRACT, then within 30 days of the audit report, CONTRACTOR shall file a copy of the audit report with County's Auditor-Controller and notify Director of the filing, unless otherwise provided by Applicable Law. Subject to Applicable Law, COUNTY shall make a reasonable effort to maintain the confidentiality of such audit report(s)

E. Submission of Records

CONTRACTOR shall submit to Director, without charge to COUNTY or charge to Customers, any Records relating to Diversion requested by Director to assist COUNTY in meeting obligations imposed by Federal, State, and local laws. CONTRACTOR shall submit those Records using COUNTY's Solid Waste Information Management System (SWIMS) forms or as requested by Director.

F. Public Record Request

1. Exclusive Property

The following become the exclusive property of COUNTY:

- Any Record or other document that CONTRACTOR gives Director, including about the procurement of this CONTRACT (such as proposals);
- Any Record or other document that Director obtains about Director's audit or inspection under this CONTRACT, including books and accounting records.

The above Records or other documents become a matter of public record and shall be regarded as public records, *except* if CONTRACTOR marks them as a "trade secret," "confidential," or "proprietary," they will be deemed excluded from disclosure under Government Code 6250 et seq. (Public Records Act). However, if a requestor seeking records marked "trade secret," "confidential," or "proprietary" does not agree that the records are exempt, then COUNTY will notify the CONTRACTOR that such records will be produced, unless the CONTRACTOR intercedes and files an injunction or other action to legally prevent disclosure.

CONTRACTOR agrees that COUNTY shall not in any way be liable or responsible for the disclosure of any such records including, with limitation, those so marked, if law requires disclosure, or by an order issued by a court of competent jurisdiction.

2. Defend, Indemnify and Hold COUNTY Harmless

CONTRACTOR shall defend, indemnify and hold harmless County from all costs and expenses, including reasonable attorney's fees, in connection with any requested action or liability arising under the Public Records Act, including request for any of the Records or other documents marked "trade secret," "confidential," or "proprietary." CONTRACTOR releases COUNTY from liability or responsibility for disclosing Records or other documents including those so marked, if Applicable Law require disclosure, including an order issued by a court of competent jurisdiction.

SECTION 10 - REPORTS

A. Types and Content

1. Monthly Data

Within 30 days after the end of each calendar quarter, CONTRACTOR shall complete and submit the data electronically for each individual calendar month. Upon Director request, monthly data shall be submitted as soon as possible. CONTRACTOR shall complete and submit SWIMS Forms C, L, T, and V accessible through SWIMS and e-mail Collection route maps and schedule if any map or schedule has changed during the prior month. See sample in Item E of Exhibit 16.

2. Quarterly Reports

Within 30 days after the end of each calendar quarter, CONTRACTOR shall submit the Quarterly Report for the preceding three calendar months ending with that month to Director using the form provided by Director, which includes the following information:

a. *Rejected Recyclables and Green Waste*

Number of loads and tons of materials in Recycling or Green Waste loads rejected for Processing together with the reason for rejection and facility at which the rejected materials were Disposed.

b. *Educational Materials*

A report of educational materials distributed, events held, and any events attended by CONTRACTOR to its Customers.

c. *Non-Collection Notices*

The number of Non-Collection notices issued and the reasons for issuance.

d. *Customer List*

CONTRACTOR customer service list (a SWIMS form), which includes a list of all current and closed accounts, account numbers, name associated with each account, customer addresses, level of service provided at each address, services provided that are not Contract Services, billing and payment dates, payment received from each Customer, and any other information associated with Task 1 Services as requested by Director.

GDD contracts will need to include all locations receiving service, both those who receive only the service paid through their property taxes and those who pay for Additional Customer Services;

3. Annual Report

On or before each February 28, CONTRACTOR shall submit the Annual Report to Director in a form satisfactory to Director, for the preceding Calendar Year, including the following information:

a. *Waste Diversion Program Implementation*

A report of CONTRACTOR'S compliance with its Performance Obligations with respect to Waste Diversion Program implementation during the preceding Calendar Year.

b. *Subcontractors*

An updated list naming all Subcontractors, the amount of Goods or Services that each Subcontractor provides to CONTRACTOR, and a description of CONTRACTOR'S relationships to each Subcontractor (including ownership interests) in accordance with Item 9M of Exhibit 5.

c. *South Coast Air Quality Management District Rule 1193*

Each Vehicle's compliance with South Coast Air Quality Management District Rule 1193, Clean On-Road Residential and Commercial Collection Vehicles, and Diesel Particulate Matter Control Measures (13 California Code of Regulations 202 et seq.).

d. *Task 2 Services Information*

Information relating to Task 2 Services requested by Director.

e. *Scavenging*

A narrative description of efforts made to deter and prevent unauthorized removal or scavenging of Recyclables.

f. *Vehicles*

An inventory of Vehicles assigned to the service area and information on each Vehicle including its number, fuel type, year, make, model, license plate number, VIN number, assigned route with start and finish points, days of service, type of material collected, and number of accounts being serviced. CONTRACTOR shall update and submit

immediately if any Vehicle, route or information has changed during the prior year.

4. Reports of Violators

If CONTRACTOR discovers that any Person is providing MSW Management Services in the Service Area that are not authorized by Director or are in Violation of Applicable Law, then CONTRACTOR shall promptly e-mail Director with the following:

- The identity and address of the Person ("Violator"), if known;
- The facts and documentation supporting CONTRACTOR'S report; and
- Any other information or documentation about the Violator and CONTRACTOR'S report that Director may reasonably request.

COUNTY acknowledges that CONTRACTOR may seek legal or injunctive relief against the Violator in accordance with Applicable Law to cease providing those MSW Management Services. Notwithstanding the foregoing, COUNTY is not liable to CONTRACTOR, and CONTRACTOR hereby releases COUNTY about any act of a Violator.

B. Submission of Reports

CONTRACTOR shall submit Reports in a format compatible with COUNTY'S computers and shall submit reports using the following methods:

1. Monthly Reports

Submitted electronically by using forms available through COUNTY's Solid Waste Information Management System (SWIMS), in accordance with this Section and Section 12.

2. Quarterly Reports and Annual Report

Submitted via e-mail or printed copy, as determined by Director, in accordance with this Section and Section 12.

C. Reporting Adverse Information

CONTRACTOR shall provide Director copies of all reports, pleadings, applications, notifications, and notices of violation, communications or other material directly relating to its Performance Obligations submitted by CONTRACTOR to, or received by CONTRACTOR from Regulatory Agencies, including any of the following:

- The United States or California Environmental Protection Agency;
- CalRecycle;

- The Securities and Exchange Commission;
- Any other Regulatory Agency;
- Any Federal, State, or County court.

CONTRACTOR shall submit copies to Director simultaneously with CONTRACTOR'S submission of those materials to those entities. At Director's request, CONTRACTOR shall promptly make available to Director any other correspondence between CONTRACTOR and those entities.

D. County's Right to Request Information

At Director's request, CONTRACTOR shall promptly provide to Director additional information reasonably and directly pertaining to this CONTRACT (including substantiation of information submitted in Reports).

SECTION 11 - SUBSTITUTE, EMERGENCY, AND BACK-UP SERVICE

A. Director's Right to Provide Contract Services

1. Events

COUNTY may provide, or contract with a third party to provide, for the performance of, any or all Customers services in either of the following events, determined by Director in its sole discretion:

a. *Unable for a Period of 48 Hours to Collect*

- For 48 consecutive hours CONTRACTOR does not Collect and Dispose of any type of Solid Waste for any reason, including Uncontrollable Circumstances, or
- Director determines there is danger to public health, safety, or welfare.

b. *COUNTY Suspends or Terminates CONTRACT*

County suspends or terminates all or a portion of the CONTRACT.

COUNTY has no obligation to continue providing any or all Contract Services. It may stop providing them at any time, in its sole discretion. However, COUNTY may continue to provide those Contract Services until either of the following occurs:

- CONTRACTOR demonstrates to Director's satisfaction that CONTRACTOR is ready, willing, and able to resume providing timely and full Contract Services, or
- Director can make alternative arrangements for providing MSW Management Services comparable to Contract Services in scope and price. Alternative arrangements may include contracting with another, third-party service provider.

2. Notice

Director may give CONTRACTOR oral notice that Director is exercising its right to perform Task 1 and Task 2 Services, which notice is effective immediately, but must confirm oral notice with a Notice within 24 hours thereafter.

3. Stipulations

CONTRACTOR stipulates that COUNTY'S exercise of rights under this Section does not constitute a taking of private property for which COUNTY must compensate CONTRACTOR, shall not create any liability on the part

of COUNTY to CONTRACTOR, and does not exempt CONTRACTOR from any Indemnities, which Parties acknowledge are intended to extend to circumstances arising under this Section. However, CONTRACTOR is not required to indemnify COUNTY against claims and damages arising from the negligence or misconduct of COUNTY officers and employees (other than employees of CONTRACTOR at the time COUNTY began performing Task 1 and Task 2 Services) and agents driving Vehicles. COUNTY shall indemnify CONTRACTOR, its Affiliates and its and their officers, directors, employees, and agents from and against damages, costs, or other expenses or losses they incur arising out of or relating to that negligence or misconduct.

4. Rental and Other Compensation

a. *Uncontrollable Circumstances*

If an event enumerated in Items A1a or A1b in Section 11 is due to Uncontrollable Circumstances, then COUNTY shall pay CONTRACTOR the following Direct Costs of having CONTRACTOR's personnel operate CONTRACTOR's equipment or vehicles, that CONTRACTOR is not being compensated for through charging and collecting Rates:

(1) Rental Fees

Rental fees for the use of equipment equal to fair market value thereof as determined by an independent appraiser selected by the Parties.

(2) Vehicles

CONTRACTOR'S Direct Costs of providing Vehicles with fuel, oil, and other maintenance.

(3) Personnel

CONTRACTOR'S Direct Costs of making CONTRACTOR'S personnel available to COUNTY, including Direct Costs of using CONTRACTOR's personnel to operate CONTRACTOR's equipment or vehicles.

The Parties shall select an appraiser as follows: within ten days after CONTRACTOR requests payment of rental fees in events described in Item (i) of this subsection 8a, each Party will prepare a separate list of five Persons who do not work for either Party having experience in solid waste equipment appraisal, in numerical order with the first preference at the top, and exchange and compare lists. The Person ranking highest on the two lists by having the lowest total

rank order position on the two lists is the appraiser. In case of a tie in scores, the Person having the smallest difference between the rankings of the two Parties is selected; a coin toss determines other ties. If no Person appears on both lists, this procedure is repeated. If selection is not completed after the exchange of three lists or 60 days, whichever comes first, then each Party will select one Person having the qualifications and experience described above and those two Persons will together select an appraiser.

b. Other Than Uncontrollable Circumstances

If an event enumerated in Items A1a or A1b in Section 11 is not due to Uncontrollable Circumstances, then COUNTY will not be obligated to pay the compensation and CONTRACTOR shall pay County's Reimbursement Costs within 10 days of COUNTY'S submitting an invoice therefore. If CONTRACTOR does not so timely pay, COUNTY may draw upon any performance bond, letter of credit, or other security provided under this CONTRACT.

B. Emergency Assistance (Contract Services)

CONTRACTOR shall provide MSW Services requested by County in the following circumstances:

- Solid Waste in any part of the unincorporated area of COUNTY is not collected, and
- In the judgment of Director, the uncollected solid waste creates a danger to public health, safety, or welfare.

Reasons for non-collection include earthquake, fire, mudslide, storm, riot, or civil disturbance, and terminated hauler contracts.

- An example of MSW Management Services is providing Vehicles and staff to cleanup, Collect, transport, and Dispose/Divert any Solid Waste, such as rubble, mud, and fallen trees, from the public right-of-way.
- Another example is holding a drop-off event for County residents to bring Solid Waste when their hauler is not providing service.

CONTRACTOR acknowledges that under emergency circumstances, CONTRACTOR may be required to Collect Solid Waste from another waste hauler's Containers. Also, another waste hauler may Collect Solid Waste from CONTRACTOR's Containers.

Prior to performing any work, CONTRACTOR is to consult with Director regarding the number of Vehicles and staff, and duration of cleanup. This includes vehicle certification discussed in more detail below. CONTRACTOR shall charge COUNTY for requested MSW Management Services in amounts no greater than the following:

1. Task 1 Services

Fees with respect to Solid Waste discarded in Containers. Examples include:

- Provide an additional day of service to Occupants; or
- Provide service to Persons outside the Service Area such as to the City of Glendora residents if their waste hauler is unable to Collect Refuse after a major earthquake and the city has an agreement with COUNTY for assistance. If location is not near Service Area, COUNTY will pay a fair price for additional transportation or Disposal costs based on comparable MSW Management Services.

2. Solid Waste Not Discarded in Containers

Fees per ton for Disposal* (with respect to Solid Waste, including Abandoned Waste, not discarded in Containers) as provided in Attachment 11-4, Emergency Service Fees of Exhibit 11. Director may require CONTRACTOR to obtain consent or acknowledgement from property owners prior to removal of Solid Waste or debris. This may be in the form of an agreement to pay for such services.

3. Roll-Off Containers or Drop-Off Events

Fees the CONTRACTOR charges for comparable MSW Management Services (with respect to Solid Waste not discarded in Containers) such as roll-off containers or drop-off events.

4. Palm Frond Collection

Fees per hour per vehicle* as proposed in Attachment 11-4, Emergency Service Fees of Exhibit 11 if significant amounts of palm fronds fall from trees, CONTRACTOR shall Sweep areas requested, Collect from right-of-way, and Dispose of palm fronds.

* Dollar amounts are subject to an annual Cost of Living Adjustment using the Consumer Price Index identified in Item C of Exhibit 7.

None of these fees can be greater than the limits provided in Item C10 of Section 7, Most Favored Public Entity, unless Director, at his sole discretion, provides authorization based on information provided by CONTRACTOR substantiating the need for an increase.

CONTRACTOR shall cooperate with all Regulatory Agencies, including COUNTY, State of California, and Federal officials in filing information related to a regional, State, or Federally-declared state of emergency or disaster as to which CONTRACTOR has provided equipment and drivers under this CONTRACT. Each vehicle used to transport Solid Waste must be assigned a unique number for

tracking and invoice reconciliation. CONTRACTOR shall keep records of relative information, found on a typical weigh ticket, including the location of the source of Collection, location of Disposal/Diversion, vehicle number, tonnages, and type of material. CONTRACTOR shall have any vehicles used during an emergency certified for compliance with Federal Emergency Management Agency (FEMA) requirements for reimbursement. Additionally, if Director has directed residences or businesses to place their debris in the public right-of-way outside the terms of Contract Services, including bulky Items, excess solid waste, or Construction and Demolition in quantities that exceeds the limit of two 70-pound containers, Director may request CONTRACTOR to take geotagged photographs of the debris that include adequate background to provide evidence of the location.

Director may direct CONTRACTOR to deliver Solid Waste to any specified location, including a materials recovery facility, landfill, sediment placement site, or a debris placement sight. Upon Director request, CONTRACTOR shall deliver Solid Waste to any location determined by CONTRACTOR.

CONTRACTOR shall give first consideration to COUNTY in the event of a major disaster such as an earthquake, fire, mudslide, storm, riot, or civil disturbance as declared by the President of the United States, Governor of California, or the Board of Supervisors.

5. Billing

CONTRACTOR shall charge COUNTY no more than the Emergency Service Fees in Attachment 11-4, Emergency Service Fees.

CONTRACTOR shall bill COUNTY monthly for Emergency Services performed during the preceding month by invoice (original and a copy) in a form satisfactory to Director. COUNTY will pay Emergency Service Fees to the CONTRACTOR within 30 days of receipt and approval of a properly completed and undisputed invoice. If CONTRACTOR is certified by COUNTY as a Local Small Business Enterprise, COUNTY will pay CONTRACTOR in accordance with Board of Supervisors Policy No. 3.035, Small Business Liaison and Prompt Payment Program.

The Itemized invoice shall contain a reference to the name of the Service Area and Environmental Programs Division, Residential Franchise/Garbage Disposal District Section. CONTRACTOR shall submit invoices to:

County of Los Angeles Department of Public Works
Attention Fiscal Division, Accounts Payable
P.O. Box 7508
Alhambra, CA 91802-7508

C. Backup Service Plan

CONTRACTOR shall implement its Backup Service Plan within seven days of Director request if Customer's Solid Waste is not Collected at Customer's Set-Out Site or Abandoned Waste is not Collected for any reason, including uncontrollable circumstances. An example is if CONTRACTOR'S drivers' strike or it is not possible to provide Contract Services in difficult to service areas due to severe weather conditions, especially on hillsides. CONTRACTOR shall include the provisions:

1. Dumpsters or roll-off containers

Provide conveniently located Dumpsters or roll-off containers where Customers may discard Solid Waste.

2. Self-hauling Solid Waste

Offer Customers the option of self-hauling Solid Waste to a transfer station or disposal facility.

3. Inform Customers

Inform Customers of procedures for handling Solid Waste, preventing litter and discouraging vectors (such as keeping Carts in their storage place and not at Set-Out Sites, discarding excess Solid Waste in closed plastic bags and not loose in Carts).

4. Customer Service Fee Refund Policy

Describe any Customer Service Fee refund policy for missed Task 1 Services.

5. Replacement Drivers

Provide replacements for drivers and other employees who are not providing Collection or other Contract Services (such as supervisory personnel or management, or employees of Affiliates or other solid waste management companies), in cases of strikes of CONTRACTOR drivers, and security for those drivers and other employees.

6. Priority Service Customers

Identify customers that require priority service.

D. Use of Goods, Services and Property

1. Cart Acquisition Contracts

CONTRACTOR acknowledges that COUNTY must have full use and possession of Carts to secure its rights under this Contract, including both the following:

- Providing substitute franchise service in accordance with its remedies under Part 6 of Exhibit 5 for Breach or default, and
- Purchasing Carts upon termination of this Contract.

Therefore, if CONTRACTOR does not own Carts outright without encumbrance, any Cart Acquisition Contract must allow the Guarantor, COUNTY or COUNTY designee to do all the following:

- Assume CONTRACTOR's obligations under the Cart Acquisition Contract,
- Take use and possession of the Carts, and
- Obtain the benefits of any outstanding Cart warranties.

"Cart Acquisition Contract" means an instrument establishing a security interest in the Carts or that otherwise encumbers or limits CONTRACTOR's interest in Carts, including any of the following:

- Lease or lease-purchase agreement,
- Installment sales or other financing contract, or
- Note or other loan documentation.

2. Inventory

CONTRACTOR shall store unused Carts in a secure location. CONTRACTOR shall update its Cart inventory at both following times:

- In each Monthly Report and Annual Report, and
- Within one week of COUNTY request

3. Insurance

If COUNTY or Customers have possession and use of Goods, Services and Property, CONTRACTOR shall execute whatever documentation its liability insurers require to ensure that COUNTY and Customers are protected and covered by CONTRACTOR's general and automobile policies, including requesting and executing endorsements to those policies. CONTRACTOR is not obligated to pay any additional cost of those endorsements unless COUNTY reimburses CONTRACTOR for those costs. COUNTY may pay for any endorsements, additional premiums or other costs. CONTRACTOR authorizes COUNTY to call and confer with CONTRACTOR's insurance broker to determine what, if any, documentation or actions are necessary to achieve protection satisfactory to COUNTY. Upon COUNTY REQUEST, CONTRACTOR shall direct its insurance broker to cooperate with and take

direction from COUNTY. CONTRACTOR may not rescind that authorization without COUNTY consent.

4. Vehicle Certification for FEMA

CONTRACTOR shall cooperate with COUNTY to certify all Vehicles to be used for emergency work. CONTRACTOR shall not use non-certified Vehicles unless approved by Director.

SECTION 12 - ENFORCEMENT OF CONTRACT

A. As Provided by Law

Either Party may avail itself of any remedy available under law.

B. COUNTY'S Additional Remedies

Without limiting COUNTY'S remedies otherwise available under this CONTRACT in law or equity, at its option, COUNTY may enforce a Breach in any or all the following ways:

- Execute alternative CONTRACTs for MSW Management Services in the event of CONTRACTOR Default
- Seek to obtain injunctive relief and/or damages
- Assess damages under Item D of this Exhibit
- With respect to a CONTRACTOR Default under Part 6B3 of Exhibit 5 (Failure to Provide Insurance, Bonds), immediately withhold payments due CONTRACTOR
- Draw on Performance Assurance/Letter of Credit under Section 15

C. Injunctive Relief

CONTRACTOR acknowledges that COUNTY'S remedy of damages for a Breach may be inadequate for reasons including the following:

- The urgency of timely, continuous, and high-quality Task 1 and Task 2 Services, including Collection, transportation, and/or transfer for Disposal of wastes which constitute a threat to public health;
- The long time and significant commitment of money and personnel and elected officials (both COUNTY staff and private consultants, including engineers, procurement counsel, citizens, public agency colleagues, and elected County officials) invested in this CONTRACT, including developing COUNTY'S Option Analysis dated February 2001 and implementing its recommendations through numerous meetings of a Working Group comprised of Solid Waste industry representatives from small and large businesses, requesting and evaluating qualifications and proposals for this CONTRACT (including CONTRACTOR'S), reviewing and commenting on documentation submitted by CONTRACTOR in conjunction with execution of this CONTRACT, and review of CONTRACTOR Documentation;
- The time and investment of personnel and elected officials described in the preceding paragraph to develop alternative Solid Waste services comparable to Task 1 and Task 2 Services for the price provided under this CONTRACT, and to negotiate new contracts therefore; and

- COUNTY'S reliance on CONTRACTOR'S technical Solid Waste management expertise.

Consequently, COUNTY is entitled to all available equitable remedies, including injunctive relief.

D. Recovery of Damages

1. Compensatory

COUNTY may seek compensatory damages, including, but not limited to the following:

- Amounts equal to any Franchise Fees, liquidated damages, or other amounts that CONTRACTOR has previously paid to COUNTY but are subsequently recovered from COUNTY by a trustee in bankruptcy as preferential payments or otherwise;
- If COUNTY terminates this CONTRACT for a CONTRACTOR Default or in the event of Criminal Activity in accordance with Part 6D2a of Exhibit 5, costs incurred by COUNTY to provide or reprocure MSW Management Services in lieu of Task 1 and Task 2 Services;
- If COUNTY terminates this CONTRACT before expiration for a CONTRACTOR Default or in the event of Criminal Activity in accordance with Part 6D2a of Exhibit 5, costs of MSW Management Services provided or reprocured in lieu of Task 1 and Task 2 services more than Customer Service Fees/County Service Fees for the balance of the Term remaining if this CONTRACT had not been terminated; and
- In the event of CONTRACTOR DEFAULT under Part 6B3 of Exhibit 5 (Failure to Provide Insurance, Bond), in COUNTY'S sole discretion, obtain damages resulting from that DEFAULT.

COUNTY may draw upon the performance bond, letter of credit, certificate of deposit, or other form of performance assurance provided by CONTRACTOR in accordance with Section 15 to pay compensatory damages.

For CONTRACTOR'S misrepresentation regarding contingent fees in Attachment 5-9H, in addition to terminating this CONTRACT, COUNTY may recover from CONTRACTOR the full amount of the proscribed commission, percentage, brokerage, or contingent fee.

2. Liquidated Damages

COUNTY may seek liquidated damages listed in Attachment 12-D2.

The Parties have set these liquidated damages in recognition of the following circumstances existing at the time of the formation of this CONTRACT:

- a. COUNTY incurred considerable time and expense procuring this CONTRACT to secure an improved level of Collection quality and increased Customer and Occupant satisfaction. Therefore, consistent and reliable Task 1 and Task 2 Services are of the utmost importance to COUNTY and Customers and Occupants.
- b. COUNTY has considered and relied on CONTRACTOR'S representations as to its quality of service commitment in entering into this CONTRACT, and CONTRACTOR'S Breach represents a loss of bargain to COUNTY. CONTRACTOR is experienced in providing services like Task 1 and Task 2 Services.
- c. Quantified standards of performance are necessary and appropriate to ensure quality, consistent, and reliable Collection, and if CONTRACTOR fails to meet its Performance Obligations, COUNTY will suffer damages (including its Customers and Occupants' inconvenience; anxiety, frustration, potential political pressure, criticism, and complaint by Customers and Occupants; lost Supervisors and staff time; deprivation of the benefits of this CONTRACT and loss of bargain) in subjective ways and in varying degrees of intensity that are incapable of measurement in precise monetary terms, and that it is and will be impracticable and extremely difficult to ascertain and determine the value thereof. It would be difficult for COUNTY to prove its loss resulting from CONTRACTOR'S Breaches and nonperformance or untimely, negligent, or inadequate performance of County Services.
- d. The CONTRACT contains a reasonable statement of Task 1 and Task 2 Services in order that the Parties will realize their expectations. COUNTY expects that CONTRACTOR shall perform Task 1 and Task 2 Services with due care in a workmanlike, competent, timely, and cost-efficient manner. CONTRACTOR expects to realize a profit by performing Task 1 and Task 2 Services in accordance with the terms and conditions of the CONTRACT for County Service Fees.
- e. In addition, in the event of Breach or CONTRACTOR Default, urgency of protecting public health and safety may necessitate that COUNTY enter into emergency or short-term arrangements for services without competitive procurement at prices substantially

greater than under this CONTRACT, and the monetary loss resulting there from is impossible to precisely quantify. Time is of the essence.

- f. The CONTRACTOR accepts COUNTY'S assessment of liquidated damages for certain Breaches as part of the consideration CONTRACTOR offers to COUNTY for the award of this CONTRACT to CONTRACTOR.
- g. Lastly, termination of this CONTRACT for CONTRACTOR Default and other remedies provided in this CONTRACT are, at best, a means of future correction and not remedies that make COUNTY whole for past Breaches and CONTRACTOR Defaults.

Therefore, the Parties agree that the liquidated damages listed in Exhibit 12-D2 represent a reasonable estimate and fair approximation of the amount of damages COUNTY would incur as a consequence of CONTRACTOR'S Breach corresponding to each Item of specified liquidated damages, considering all the circumstances existing on the date of this CONTRACT, including the relationship of the sums to the range of harm to COUNTY that reasonably could be anticipated and anticipation that proof of actual damages would be costly or inconvenient.

In signing this CONTRACT, each Party specifically confirms the following:

- The accuracy of the statements made above, and
- The fact that each Party had many opportunities to consult with legal counsel and obtain an explanation of this liquidated damage provision at the time that this CONTRACT was made.

E. County's Reimbursement Costs

CONTRACTOR shall pay COUNTY promptly upon request, COUNTY'S Reimbursement Costs of conducting a nonroutine investigation of any alleged Breach, when appropriate in judgment of Director. CONTRACTOR shall reimburse COUNTY for COUNTY'S Reimbursement Costs incurred because of CONTRACTOR'S Breach, including failure to maintain insurance.

F. Waiver

No waiver by County of any Breach of any provision of this CONTRACT constitutes a waiver of any other Breach of that provision. Failure of COUNTY to enforce at any time, or from time to time, any provision of this CONTRACT will not be construed as a waiver thereof. The rights and remedies set forth in this Item F are exclusive and are in addition to any other rights and remedies provided by law or under this CONTRACT.

SECTION 13 - UNPERMITTED WASTE SCREENING AND REPORTING (Contract Services)

A. Protocol

CONTRACTOR shall develop and implement the Unpermitted Waste Screening Protocol in compliance with Applicable Law and including the following provisions:

- Ongoing employee training in identification, safety and notification procedures, including leaving Non-Collection notices, when safe;
- Means of driver inspection, such as visual inspection during tipping of Carts into Vehicles;
- Immediate driver response, such as load segregation;
- Driver notification, such as calling CONTRACTOR'S dispatcher or field supervisor;
- Notification of appropriate local agency or department;
- Appropriate action, such as segregation and containerization for manifesting and transport for disposal in accordance with Applicable Law or securing services of permitted handling and transport company;
- Compliance with Applicable Law, including regulations of the United States Department of Transportation (DOT) (Title 49 CFR) and of the United States Environmental Protection Agency (Title 40 CFR); and
- Labels on Containers, described in Item D of this Section.

B. Prohibition on Collection

CONTRACTOR shall not Collect any Unpermitted Waste that it finds in Refuse, Recyclables, or Green Waste unless it is licensed under Applicable Law. If CONTRACTOR finds Unpermitted Waste it shall notify all Persons in compliance with Applicable Law.

C. Notice to Director

If CONTRACTOR sees anything that it reasonably believes or suspects may be Unpermitted Waste on any public property in COUNTY, CONTRACTOR shall immediately notify Director and all Persons in compliance with Applicable Law. Public property includes storm drains, streets, and other public rights of way.

D. Labels

CONTRACTOR shall conspicuously label Containers with embossing or other secure means prohibiting Customers from discarding Unpermitted Waste. CONTRACTOR shall submit the label and text for Director approval prior to placing any purchase order for Containers. Item D9 of Exhibit 3A1 contains additional Container requirements.

SECTION 14 - EXECUTION OF CONTRACT

A. Execution in Counterparts

This CONTRACT, including dated signatures on amended Exhibits and attachments to those Exhibits, may be signed in any number of original counterparts. All counterparts constitute the same CONTRACT.

B. Authority to Execute

COUNTY warrants that the individual signing this CONTRACT has been duly authorized by COUNTY to sign this CONTRACT on behalf of COUNTY and has the full right, power, and authority to bind COUNTY to this CONTRACT. CONTRACTOR warrants that the individual signing this CONTRACT below has been duly authorized by CONTRACTOR to sign this CONTRACT on behalf of CONTRACTOR and has the full right, power, and authority to bind CONTRACTOR to this CONTRACT.

SECTION 15 - PERFORMANCE ASSURANCE

A. Performance Bonds, Other Security

CONTRACTOR shall secure and maintain throughout the Term and until CONTRACTOR has complied with all its obligations that survive the Expiration Date a faithful performance bond, approved by COUNTY. The performance bond must be in a form satisfactory to COUNTY or, at COUNTY'S sole and absolute discretion, any alternative security acceptable to Director, including cash, certified check payable to COUNTY, certificate of deposit, or letter of credit (together, "**Performance Assurance**"), in the amount not less than \$50,000.

The Performance Assurance secures full and timely satisfaction of Performance Obligations for both Task 1 and Task 2 services.

CONTRACTOR shall provide a Performance Assurance in the amount listed in the table below for the period beginning on the Execution Date and ending on the last day of the first Contract Year.

Service Area	Amount of Performance Assurance
Lennox	\$208,089.15

Beginning on the first day of the next Contract Year, and in all subsequent Contract Years, that amount must be not less than the sum of:

- 15 percent of CONTRACTOR'S Gross Receipts from Task 1 Services minus any Franchise Fees for the prior Contract Year;
- + 15 percent of CONTRACTOR'S Gross Receipts from Task 2 Services for the prior Contract Year
- + 110 percent of any Franchise Fees paid by CONTRACTOR during the first six months of the prior Contract Year;
- + 110 percent of any liquidated damages assessed CONTRACTOR by COUNTY during the first six months of the prior Contract Year; and
- + Up to \$50,000, at the discretion of Director;
- = SUM OF PERFORMANCE ASSURANCE (\$50,000 MINIMUM)

A performance bond must be payable to COUNTY and executed by a corporate surety licensed to transact business (admitted) as a surety in the State of California. The corporate surety must have an A.M. Best Rating of not less than A: VII, unless otherwise approved by Director. The form of performance bond may not allow the bond surety to substitute another Person to perform Task 1 and Task 2 services but must provide for payment of moneys to COUNTY to; (1) secure substitute Task 1 and Task 2 services; (2) remedy damages incurred by COUNTY, including reasonable expenses, attorney's fees, and liquidated and compensatory damages; (3) ensure satisfaction of all Performance Obligations, including

payment of Franchise Fees; and, (4) repay any money recovered from COUNTY in any bankruptcy or similar proceedings relating to CONTRACTOR. The performance bond must be conditioned on faithful performance by CONTRACTOR of all the terms and conditions of this CONTRACT, including payment of Franchise Fees and any liquidated damages.

Each Performance Assurance must be renewed to provide for continuing liability in the above amount notwithstanding any payment or recovery thereon. At least 30 days prior to the Execution Date and 30 days prior to any renewal of the Performance Assurance, CONTRACTOR shall deliver the Performance Assurance to Director.

Director may verify the accuracy and authenticity of the Performance Assurance submitted.

B. Further Assurances

In addition to all other rights and remedies it may have, within five days of County request CONTRACTOR will provide reasonable assurances that it can timely and fully meet its obligations under this CONTRACT in any or all of in the following events:

1. Labor

CONTRACTOR is the subject of any labor unrest (including work stoppage or slowdown, sick-out, picketing and other concerted job actions).

2. Tipping Fees

CONTRACTOR does not pay an Identified Solid Waste Facility for services.

3. Employee Wages

CONTRACTOR does not pay wages to its employees, provide workers' compensation insurance required by law, or pays employment-related taxes or fees.

4. County

CONTRACTOR does not pay COUNTY any amount that COUNTY has charged CONTRACTOR.

5. Meet Obligation

In the COUNTY's judgment, the occurrence of either of the following events jeopardizes CONTRACTOR's ability to timely and fully meet its obligations

under this CONTRACT:

- CONTRACTOR does not regularly pay its bills when due, or
- The entering of any judgment against CONTRACTOR or any Guarantor with respect to Criminal Conduct by CONTRACTOR or Guarantor.

"Assurance of Performance" means any or all of the following actions, as COUNTY requests:

- Reduction or elimination of insurance deductibles or self-insured retention,
- Providing or increasing the size of a letter of credit, or
- Providing an additional performance bond, certificate of deposit or other instrument.

SECTION 16 - CONTRACT SERVICE AREA INFORMATION

CONTRACTOR is to use and follow the information below provided by Director. Not every Service Area has a sample of every Item as it may not be applicable. For example, East Los Angeles has no history of bears opening Refuse Containers so a Bear Map will not be included. Many of the required documents in Exhibit 3D will have a sample listed below.

A. Maps

1. Service Area and Collection Schedule
2. Hot Zones
3. Difficult to Service
4. Bear Zone
5. Alleys
6. Public Receptacles
7. Roll-Out Minimum Service

B. Sample Graphics

1. Cart Lid Labels
2. Dumpster Labels
3. Vehicle Billboards

C. Data

1. Street and Alley Miles
2. Difficult to Service Addresses
3. Public Receptacles Locations
4. Roll-Out Minimum Service Locations
5. Customer Information
 - Number of Customers
 - Number of Containers of each Size
 - Number of Senior Discounts
 - Number of Extra Services (Manure, Bear Cart, Roll-Out, etc.)
 - Number of Extra Containers
6. Tonnages
7. Item Typical Weights
 - CalRecycle Conversion Factor
 - FRN
8. Parcels

D. Outreach

1. COUNTY and CONTRACTOR Letters
2. Non-Collection Notice
3. Customer Terms and Conditions

IN WITNESS WHEREOF, COUNTY has by order of its Board of Supervisors caused this CONTRACT to be signed by Director, and CONTRACTOR has caused this CONTRACT to be signed by its duly authorized officers, as of the date first written above.

COUNTY OF LOS ANGELES

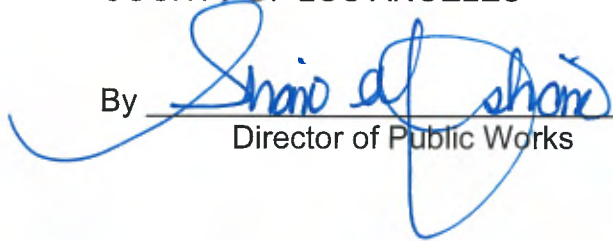
By  _____
Director of Public Works

APPROVED AS TO FORM:

County Counsel

By  _____
Deputy

WARE DISPOSAL, INC.

By _____
President

Type or Print Name

Secretary

Type or Print Name

IN WITNESS WHEREOF, COUNTY has by order of its Board of Supervisors caused this CONTRACT to be signed by Director, and CONTRACTOR has caused this CONTRACT to be signed by its duly authorized officers, as of the date first written above.

COUNTY OF LOS ANGELES

By _____
Director of Public Works

APPROVED AS TO FORM:

County Counsel

By _____
Deputy

WARE DISPOSAL, INC.

By 
President

JUDITH HELAINE WARE

Type or Print Name

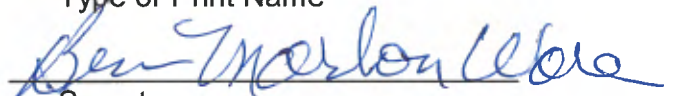
Secretary

BEN MARLON WARE

Type or Print Name

ACKNOWLEDGMENT

A notary public or other officer completing this certificate verifies only the identity of the individual who signed the document to which this certificate is attached, and not the truthfulness, accuracy, or validity of that document.

State of California
County of Orange)

On August 9th 2018 before me, Nicholas Panos, Notary Public
(insert name and title of the officer)

personally appeared Judith Helaine Ware and Ben Marlon Ware,
who proved to me on the basis of satisfactory evidence to be the person(s) whose name(s) is/are
subscribed to the within instrument and acknowledged to me that he/she/they executed the same in
his/her/their authorized capacity(ies), and that by his/her/their signature(s) on the instrument the
person(s), or the entity upon behalf of which the person(s) acted, executed the instrument.

I certify under PENALTY OF PERJURY under the laws of the State of California that the foregoing
paragraph is true and correct.

WITNESS my hand and official seal.

Signature Nicholas Panos (Seal)

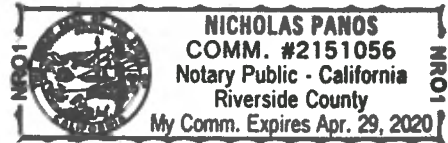

EXHIBITS TABLE OF CONTENTS

- EXHIBIT 3A1 – Task 1 Services 1
 - A. General 1
 - B. Solid Waste Collection Requirements 1
 - C. Diversion 3
 - D. Containers 4
 - E. Vehicles 10
 - F. Solid Waste Transportation, Processing, Diversion, and Disposal 13
 - G. Recyclables 14
 - H. Special Services 17
 - I. Roll-Out Services for Containers 20
 - J. Method of Payment for Task 1 Services 22
 - K. Transition Roll-Out Plan 22
 - L. Public Education and Outreach 23
 - M. CONTRACTOR Commitments Made in Proposal 29
 - N. Additional Performance Obligations Specific to this Service Area 29
 - O. Difficult to Service 29
 - P. Food Waste 30
- EXHIBIT 3A2 – Task 2 Services 31
 - A. Abandoned Waste Collection, Transportation, and Diversion/Disposal 31
 - B. Public Curbside Receptacles Collection Service 34
 - C. Abandoned Cart, Dumpster, or Roll-Off Removal 36
 - D. Vehicles 37
 - E. Homeless Encampments 39
- EXHIBIT 3A3 – Additional Services 42
 - A. Mulch and Compost Giveaway Program (Item H7 of Exhibit 3A1) 42
 - B. Bulky Item and Excess Solid Waste Collection (Item H3 of Exhibit 3A1) 42
 - C. Annual Curbside Cleanup Events Services (Item H2 of Exhibit 3A1) 43
- EXHIBIT 3D – Contractor Documentation 44
 - A. Notice to Director Required 44
 - B. Director Consent Required 44
- EXHIBIT 5 – Additional Contract Language 187
- PART 3 - GENERAL CONTRACT REQUIREMENTS 187
 - A. Employment Eligibility Verification 187
 - B. Security and Background Investigations 187
 - C. Consideration of Hiring COUNTY Employees 187
 - D. Conflict of Interest 188

- E. Fair Labor Standards Act 188
- F. Record Retention and Inspection/Audit Settlement 188
- G. Compliance with COUNTY's Jury Service Program 190
- H. CONTRACTOR's Charitable Activities Compliance 191
- I. Social Enterprise Preference Program 191
- J. Local Small Business Enterprise Preference Program 192
- K. Disabled Veteran Enterprise Preference Program 193
- L. CONTRACTOR Responsibility and Debarment 194
- M. Reporting Requirements for Improper Solicitations 196
- N. COUNTY's Quality Assurance Plan 196
- O. Local Small Business Enterprise Utilization 196
- P. Compliance with COUNTY's Zero Tolerance Human Trafficking 197
- Q. Method of Payment and Required Information 197
- R. Compliance with Fair Chance Employment Practices 198
- S. Compliance with The County Policy of Equity 198

- PART 4 - INDEMNIFICATION AND INSURANCE 199
 - A. Indemnification and Release of COUNTY 199
 - B. Insurance 201
 - C. Compensation for COUNTY Costs 206
 - D. Alternative Risk Financing Programs 207

- PART 5 - Part no longer used 208

- PART 6 - DEBARMENT BREACHES AND DEFAULTS; SUSPENSION; TERMINATION . 208
 - A. Notice of Breach; CONTRACTOR Cure 208
 - B. Contractor Default. The following constitute Contractor Defaults 208
 - C. Notice of Contractor Default 211
 - D. Suspension or Termination of CONTRACT 211
 - E. CONTRACTOR Responsibility and Debarment 215
 - F. Termination For Breach Of Warranty To Maintain Compliance With County Defaulted Property Tax Reduction Program 215

- PART 7 - Part no longer used 216

- PART 8 - TRANSFER OF CONTRACT 216
 - A. COUNTY Consent 216
 - B. CONTRACTOR Demonstration 217
 - C. Payment of COUNTY's Transfer Costs 217
 - D. County's Reimbursement Costs of Enforcement 218

- PART 9 - GENERAL PROVISIONS 219
 - A. Exercise of Options 219
 - B. Independent Status 219
 - C. Damage to Property and Personal Injury 219

- D. Venue 220
- E. Changes and Amendments 220
- F. Notices 220
- G. Authorized Representative of Director 221
- H. Authority and Representations; COUNTY Disclaimer 221
- I. Limitation on Terms and Conditions 222
- J. 21-Day Notice by Customer 222
- K. Criminal Activity 222
- L. Delay of Performance Obligations 224
- M. Subcontractors 224

PART 10 - DEFINITIONS AND INTERPRETATION OF CONTRACT 225

- A. Definitions 225
- B. Interpretation and Construction 225
- C. Integration 226
- D. Governing Law 226
- E. Severability 226
- F. Interpretation 227

PART 11 - COMPLIANCE WITH LAWS AND REGULATIONS 228

- A. Applicable Law 228
- B. COUNTY Child Support Compliance Program 230
- C. County Defaulted Property Tax Reduction Program 230

PART 12 - LABOR-RELATED PROVISIONS REQUIRED IN COUNTY CONTRACTS 231

- A. Labor Code 231
- B. Notices to Employees 231
- C. Prohibition Against Use of Child Labor 233
- D. Nondiscrimination 233
- E. Safety 234
- F. COUNTY Lobbyists 235

ATTACHMENT 5-9G – Authorized Representative of COUNTY's Director 236

ATTACHMENT 5-9H – CONTRACTOR's Representations and Warranties 237

- A. Status 237
- B. Statements and Information 237
- C. No Conflicts 237
- D. No Approvals Required 237
- E. No Litigation 237
- F. Due Diligence 238
- G. Compliance with Applicable Law 238
- H. Ability to Perform 238
- I. Contingent Fees 238
- J. Opportunity to Comment 238

- K. Solid Waste Facilities 239
- L. Contractor Documentation 239
- M. Personnel 239

- ATTACHMENT 5-10A - Definitions 240

- EXHIBIT 7 – Contract Services (Adjustment of Service Fees) 258
 - A. Service Fee Schedule 258
 - B. This item is no longer used 263
 - C. Service Fee Adjustment for Annual Increase or Decrease in CPI 263
 - D. Service Fee Adjustment for Annual Increase or Decrease in Fuel 264
 - E. Service Fee Adjustment for Changes in Refuse Disposal and Green Waste
Diversion Facility Fees 265
 - F. Future Service Fee Adjustment Components 266
 - G. No Longer Used 267
 - H. Temporarily Discontinued Indices 267

- ATTACHMENT 7-1 – Service Fees Adjustment Example 268
 - A. Annual increase or decrease in CPI Example (C of Exhibit 7) 268
 - B. Annual increase or decrease in Fuel Example (D of Exhibit 7) 268
 - C. Changes in Disposal/Diversion Tipping Fees Example (E of Exhibit 7)..... 268
 - D. Weighted Service Fee Adjustment Percentage Example (C, D, and E of Exhibit 7).. 269

- ATTACHMENT 7-2.1 - Task 1 Service Fees 270

- ATTACHMENT 7-3.1 - Task 2 Service Fees 272

- ATTACHMENT 7-5 - Schedule of Prices 273

- ATTACHMENT 11-1.1 - Emergency Service Fees 276

- EXHIBIT 12-D2 - Liquidated Damages 277

- EXHIBIT 16 - Contract Service Area Information 281
 - A. Maps 281
 - B. Sample Graphics 281
 - C. Lists 281
 - D. Outreach 281

EXHIBIT 3A1 – Task 1 Services

Refuse, Recyclables, and Green Waste Cart and Dumpster Services to Occupants at Residential, Multifamily, and Commercial Premises

- A. No Longer Used
- B. Solid Waste Collection Requirements

CONTRACTOR shall Collect Refuse, Recyclables, and Green Waste in the Service Area from Containers, Bulky Items, and Excess Solid Waste, as provided in this Exhibit.

1. Days Authorized to Collect

Residential Collection is only permitted Monday through Friday, except following a Holiday. Commercial Collection is permitted Monday through Saturday, except following a Holiday.

For each Occupant CONTRACTOR shall Collect Recyclables and Green Waste on the same day that CONTRACTOR Collects the Refuse.

2. Collection Hours

CONTRACTOR shall Collect only between the hours of 6 a.m. and 6 p.m., except for Collection from Commercial Customers and Occupants in accordance with County Code, including Section 12.08.520 Refuse Collection Vehicles.

If it becomes evident that CONTRACTOR may not be able to complete its scheduled work within the required hours, CONTRACTOR shall immediately notify Director and receive consent to Collect outside of regular hours. Director may request a proposal for measures to be taken to maintain the scheduled service without delay or interruption.

CONTRACTOR shall not Collect in School Zones 30 minutes prior to the school's starting time and 30 minutes after ending time or at any time that children are present.

CONTRACTOR shall use Reasonable Business Efforts to adjust the early morning start point of Collection routes to address and minimize Occupant complaints.

3. Collection Frequency

CONTRACTOR shall Collect Solid Waste on the scheduled Collection Day, at least once per week from Occupants. The frequency of Collection may be reduced at the discretion of Director. For example, the Collection

frequency of Refuse may be reduced if Food Waste is not allowed in the Refuse Container or Recyclables Containers Collection frequency may be reduced to every other week.

Customers may increase the frequency of their Collection for an additional charge for the Customer Service Fees provided on Attachment 7-2, Task 1 Service Fees of Exhibit 7.

Dumpster Customers may also reduce the size of their Container and increase the frequency of Collection to offset the loss of capacity. CONTRACTOR must negotiate with Customer what day the extra service occurs. Customers would pay an additional charge for the Customer Service Fees provided on Attachment 7-2, Task 1 Service Fees of Exhibit 7, equivalent to the cost for transportation and nothing extra for Disposal/Diversion. For example, a business may not have space for two 3-cubic yard Refuse Dumpsters, included in their 12 Refuse Unit allocation, and they request a single 3-cubic yard Dumpsters serviced twice per week. The charge to the Customer would be the cost of one 96-gallon Refuse Container (not Refuse Unit) multiplied by 0.7.

4. Collection Schedule

CONTRACTOR shall schedule Collection in the Service Area on the Service Days as indicated on the schedule in item A1 of Exhibit 16 (Collection Schedule), or other schedule approved by Director if it significantly improves efficiencies.

Any proposed changes in the Collection schedule shall have the Service Day be one to two Service Days before streets are swept as provided in Director's schedule for street sweeping in the Service Area. Director may amend this schedule at any time, and CONTRACTOR shall use Reasonable Business Efforts to implement this amendment. CONTRACTOR shall prepare a Notice notifying the affected Customers and Occupants of the change and send such Notice to these Customers and Occupants upon receiving approval from Director.

5. Holidays

CONTRACTOR shall observe the following Holidays:

- New Year's Day
- Memorial Day
- Fourth of July
- Labor Day
- Thanksgiving Day
- Christmas Day

Collection shall be delayed one day for the Holiday and the remainder of the Holiday week. CONTRACTOR may Collect on Saturday of the same week for Residential Customers and Occupants and on Sunday for Commercial Customers and Occupants.

C. Diversion

1. Divert Materials

a. *Refuse Transport and Disposal*

CONTRACTOR shall transport all Refuse that it Collects to the Solid Waste Facility that it designates in Contractor Documentation in Exhibit 3D.

b. *Recyclables Transport and Processing*

CONTRACTOR shall transport all Recyclables that it Collects from Recyclables Containers to the Processing facility that it designates in Contractor Documentation in Exhibit 3D, such as a materials recovery facility.

CONTRACTOR shall Recycle and dismantle all E-waste that it Collects into materials that meet commercial standards for marketable commodities such as metals, plastic, and glass in a facility that operates within the United States. CONTRACTOR shall not ship any other E-waste or E-waste components outside the United States. CONTRACTOR shall demonstrate compliance with this subsection in the form of an affidavit from the proposed E-waste recycler.

c. *Green Waste Transport and Processing*

CONTRACTOR shall transport all Green Waste that it Collects from Green Waste Containers to the Processing Facility that it designates in Contractor Documentation in Exhibit 3D.

d. *Manure Transport and Processing*

If CONTRACTOR must Collect Manure in the Service Area, CONTRACTOR shall transport it to the Processing Facility that it designates in Contractor Documentation in Exhibit 3D.

2. Reasonable Business Efforts to Divert

CONTRACTOR shall use Reasonable Business Efforts to Divert the following materials that it Collects:

a. *Bulky Items*

Bulky Items including large appliances/white goods in accordance with item H3 of this Exhibit.

b. *Abandoned Waste*

Abandoned Waste Collected in accordance with Exhibit 3A2.

c. *Excess Solid Waste*

Excess Solid Waste Collected in accordance with item H3 of this Exhibit.

d. *Manure*

Manure observed in Refuse Containers by offering Manure-only Containers.

CONTRACTOR shall Dispose the items, listed in this subsection, Collected from Customers and Occupants pursuant to this CONTRACT in accordance with the following hierarchy:

a. *Reuse, as-is*

b. *Disassemble for reuse or Recycling*

c. *Recycle*

d. *Disposal*

CONTRACTOR shall not Dispose of the items, listed in this subsection, in a landfill unless the items cannot reasonably be reused or Recycled.

D. Containers

1. Standard Containers

CONTRACTOR shall provide to Occupants for each Refuse Unit assigned to the parcel, the Containers listed below. Note that most larger multi-family and Commercial Occupants use Dumpsters. CONTRACTOR shall provide the number of alternative Containers having the same aggregate capacity as CONTRACTOR would have provided to that Occupant. See Section 9 of Exhibit 3A1. Alternate Container Sizes.

a. *One 96-gallon Refuse Cart;*

b. *One 96-gallon Recyclables Cart;*

c. *One 96-gallon Green Waste Cart; and*

d. *One additional 96-gallon Recyclables Cart, upon Customer or Occupant request;*

For parcels with Refuse Units more than two 1 cubic yard, CONTRACTOR shall round up Dumpster capacity volumes to next cubic yard whole number at no additional cost to COUNTY or Customer. For example, a store assigned 3 Refuse Units is entitled to 1.5 cubic yards of capacity each week and shall be offered a 2.0 cubic yard Dumpster.

2. Extra or Larger Capacity Containers

If Customer requests an extra Container or larger capacity Container for Refuse, and/or request extra container for Recyclables or Green Waste beyond the carts as described above, the Customer shall pay CONTRACTOR the surcharge, as provided in Attachment 7-2, Task 1 Service Fees of Exhibit 7.

3. Delivery, Removal, and Exchanges

Within seven calendar days after receiving a Customers or Occupant's request for commencement or changes in Collection of Solid Waste, CONTRACTOR shall deliver Container of the Customer or Occupant's requested capacity or replace existing Container with substitute Containers of the Customer or Occupant's requested capacity. CONTRACTOR shall charge a fee according to the following:

a. *Starting or Stopping Service*

CONTRACTOR shall not charge for delivery or removal of Containers upon starting or terminating service.

b. *One Annual Exchange of Containers*

CONTRACTOR shall exchange one or more Containers for one or more Containers of a different size if requested by Customer or Occupant once each Calendar Year at no extra charge.

For example, a Customer or Occupant may ask CONTRACTOR to exchange its 96-gallon Refuse and Recyclable Containers for 64-gallon Container at no charge.

c. *Multiple Exchanges of Container(s)*

the If a Customer asks CONTRACTOR to exchange Container(s) more than once each Calendar Year as described in item b above, CONTRACTOR may charge Customer the amount provided in Attachment 7-2, Task 1 Service Fees of Exhibit 7.

CONTRACTOR shall inform Customer of the fee prior to the exchange and give Customer the option of waiting for the exchange until the next Calendar Year to avoid the charge.

d. *Cleanliness of Containers*

While CONTRACTOR is not obligated to provide new Containers to Occupants, they must provide clean Containers. This includes the delivery of additional Containers, exchange of Containers, or power washing existing Containers within 60 days of Commencement Date if incumbent is continuing to use Containers from previous contract.

4. Repair and Replacement

a. *Identification/Reporting*

CONTRACTOR shall repair or replace damaged Carts that it observes damage when providing service and upon request from Director, Customer, or Occupant.

b. *Fee*

CONTRACTOR will repair or replace Containers without cost, except in the circumstances below. CONTRACTOR may charge the Containers actual cost of repair or replacement

- Customers or Occupants do not report the theft of the Container to the police.
- The Container is damaged due to Occupant negligence such as disposing of hot ashes inside the Container or over-filling the Container so that lifting it damages the Collection Vehicle. Director's determination of Occupant negligence is final.

c. *Repair or Replacement*

CONTRACTOR shall repair or replace damaged Containers within two Service Days after CONTRACTOR observes the damaged Container or as requested by Director, Customer or Occupant. "Damage" includes missing or inoperable lids.

5. Placement (Set-Out Site)

CONTRACTOR shall arrange for the location of a Set-Out Site directly with Customer or Occupant. If no arrangement is made, then the default location is the curb of the street for the address of the Customer or Occupant or in the alley behind the Customer or Occupant's property. If CONTRACTOR Collects from any other location CONTRACTOR may be required to provide roll-out service under item I of this Exhibit.

CONTRACTOR shall return empty Containers upright and to their Set-Out Sites. CONTRACTOR shall not impede pedestrian or vehicular traffic. The

Set-Out Site should be located at the curb or as otherwise provided in County Code Section 20.72.100, except during heavy rains when CONTRACTOR shall return Containers approximately 2 feet from the curb to keep the gutter unobstructed and prevent the Containers from being washed away.

6. Inventory

CONTRACTOR shall maintain an adequate inventory of Containers and lids of each type and capacity to provide Customers and Occupants replacements within two Service Days of request. When determining adequacy, CONTRACTOR shall consider the nature of Set-Out Sites. For example, Carts placed on unlevel Set-Out Sites, such as in mountainous areas without curb and gutter, may be damaged more frequently than those placed in level Set-Out Sites. Therefore, CONTRACTOR must maintain a larger inventory of Carts for those areas.

CONTRACTOR shall notify Director if inventory is inadequate, including an explanation of why inventory dropped below the two-Service Day standard. For example, CONTRACTOR might submit its timely order for Containers but receive them later than manufacturer originally represented due to manufacturer's backlog or other delay.

7. Graffiti

CONTRACTOR shall remove any graffiti and other markings that deface or detract from the aesthetic quality of the Containers within seven calendar days of its Vehicle drivers' or route supervisors' observation and report, or upon request of Director or any other Person. If the graffiti is comprised of obscenities, removal shall be within two Service Days. Instead of removing graffiti or markings, CONTRACTOR may replace defaced Containers with clean Containers.

8. Alternative Container Sizes

If a Customer or Occupant requests alternate Container sizes, CONTRACTOR shall provide the type of Containers described in Contractor Documentation in Exhibit 3D. For the purposes of this CONTRACT, Carts with a capacity between 95 and 100 gallons are equivalent to 0.5 cubic yards. CONTRACTOR shall provide the number of alternative Containers having the same aggregate capacity as CONTRACTOR would have provided to that Occupant. For example:

- Three 32-gallon Carts instead of one 96-gallon Cart.
- One 64-gallon Cart and one 32-gallon Cart instead of one 96-gallon Cart.
- One 3-cubic yard Dumpster in lieu of six 96-gallon Carts.

9. **Additional Specifications**

CONTRACTOR shall provide to Occupant wheeled Containers compatible with automated Collection Vehicles having the specifications described in Contractor Documentation in Exhibit 3D. Director approval is required for labeling and any alternatives to the specifications below.

a. **Carts**

(1) **Color**

All Cart bodies shall be a uniform color with color coded lids. Lid colors shall distinguish the type of materials that go in each Cart such as black or brown for the Refuse Cart, blue for the Recyclables Cart, and green for the Green Waste Cart. If a Food Waste or Manure Cart is to be used, Director shall approve the proposed color.

As an alternative with approval from Director, the Refuse Cart body may be black, the Recyclables Cart body may be blue, and the Green Waste Cart body may be green, or other Director approved color.

(2) **Capacity**

CONTRACTOR shall provide Carts of an approximate capacity of 96, 64, and 32 gallons. If a Food Waste Cart is to be used, Director shall approve the proposed size.

(3) **Labeling of Body**

Containers shall clearly display CONTRACTOR's name in a contrasting color.

(4) **Labeling of Lids**

Cart lids shall be labeled similar to the template in item B1 of Exhibit 16 and shall clearly display CONTRACTOR's phone number, website, and contents for which the Container is designated, a warning that the Disposal of Unpermitted Waste in the Container is prohibited, and acceptable/not acceptable contents.

(5) **Recycled Content**

Each plastic Cart shall be constructed of recyclable content at a minimum of 25 percent post-consumer materials.

(6) **Cart Reuse**

While Carts provided to Occupants are not required to be new, they must be in reasonably good condition, including cleanliness. Director may require Refuse Carts to be washed prior to use.

b. Dumpsters

The following conditions apply when Dumpster service is provided.

(1) **Lids**

A lid shall prevent intrusion of rainwater, rodents, birds, and flies; shall prevent the contents from being carried or deposited by the elements onto the ground; and shall reduce the emission of odors.

(2) **Labeling of Body**

Dumpster bodies shall be labeled similar to the template in item B2 of Exhibit 16 and shall clearly display CONTRACTOR's phone number, website, and contents for which the Container is designated, a warning that the Disposal of Unpermitted Waste in the Container is prohibited, and acceptable/not acceptable contents. Examples of Recyclables is an important part of educating Customers and Occupants.

10. Customer or Occupant Declines a Portion of Collection Service

A Customer or Occupant may decline Refuse, Recycling, or Green Waste Collection services and therefore they may not need all three types of Containers, or may not need all the alternative Containers as provided for in Section D(1) of this Exhibit. Fees shall not be reduced for Customers declining a portion of the basic Collection services.

11. Container and/or Cart Lids Purchase Option

In the event of Breach or termination, COUNTY may purchase some or all Containers and/or Cart lids on the effective date of the contract termination Notice at a price equal to the then book value of Containers and/or Cart lids amortized straight-line over the initial seven-year Term of the CONTRACT. This includes Containers and/or Cart lids stored in CONTRACTOR's inventory for future use under the requirements of subsection 6 of this Section. CONTRACTOR shall transfer or assign to COUNTY all rights necessary to give COUNTY ownership, possession and use of Containers

and/or Cart lids, including under any Containers and lid acquisition agreement.

12. Bear-Resistant Carts

If required under Exhibit 3A3, CONTRACTOR shall offer bear-resistant 96-gallon Manure Carts.

13. Manure Service

If required under Exhibit 3A3, CONTRACTOR shall offer Manure Collection service from Manure-only Containers for the Customer Service Fees provided on the Attachment 7-2, Task 1 Service Fees of Exhibit 7.

14. Recyclables Cart with Gravity Lock

Upon Customer request, CONTRACTOR shall sell Customer, with no financial gain to CONTRACTOR, Recyclables Carts with gravity locks to prevent scavenging, to Customer at the price listed on Attachment 7-2, Task 1 Service Fees of Exhibit 7. After selling the Carts and transferring ownership to Customer, CONTRACTOR is no longer responsible for repair or replacement of the Carts. CONTRACTOR shall disclose to Customer and receive written acknowledgement from Customer, CONTRACTOR is no longer responsible for the sold Carts. If CONTRACTOR cannot give Director evidence of Customer's acknowledgment, CONTRACTOR shall continue to be responsible for repair or replacement of the Carts.

If CONTRACTOR is unable to Collect from Cart due to failure of the lock, CONTRACTOR shall require Customer to repair it, offer to repair it for a reasonable charge, or replace Cart with standard non-locking Cart at no charge.

CONTRACTOR is not obligated to deliver Recyclables Carts with gravity locks within seven days of request under Subsection 3, but CONTRACTOR must deliver those Carts within 21 days of request.

E. Vehicles

1. General

CONTRACTOR shall provide Vehicles of appropriate numbers, sizes, capacities, and functions required for the efficient Collection of different types of Solid Waste, such as Refuse, Recycling, Green Waste, Bulky Items, and Abandoned Waste. CONTRACTOR shall also provide non-compacting Vehicles for the Collection of E-waste, white goods and any other material that contains chlorofluorocarbons. Vehicles shall be so constructed such that Solid Waste or liquids will not blow, fall, sift, or leak out of the truck into the

street. CONTRACTOR shall equip Vehicles with a shovel, broom, and petroleum absorbent agents. CONTRACTOR shall comply with any additional requirement with respect to the Vehicle as set forth in Exhibit 3A3.

2. Automation

CONTRACTOR shall Collect Refuse, Recycling, and Green Waste in automated Collection Vehicles, except CONTRACTOR may Collect the following materials in non-automated Collection Vehicles:

- a. *Bulky Items including E-waste*
- b. *Holiday trees*
- c. *Solid Waste discarded at Set-Out Sites that are Difficult to Service*

3. Fuel/Power

Within the first six months after Execution, all Vehicles used for automated Collection must use Liquid Natural Gas or Compressed Natural Gas fuel, or other alternatives to diesel fuel, as approved by Director unless Contractor Documentation provides otherwise with respect to Collection at Premises that are difficult to serve as permitted in item O of this Exhibit.

4. Extra Vehicles

CONTRACTOR shall maintain enough back-up Vehicles to replace similar types of Vehicles in the event of breakdowns, complaints, and emergencies. Director may specify a minimum number of backup Vehicles.

5. Maintenance

CONTRACTOR shall maintain Vehicles reasonably clean, and in good mechanical condition, and well painted, all to the satisfaction of Director. CONTRACTOR shall maintain Records of inspections and maintenance of all mechanical equipment that CONTRACTOR uses to provide Contract Services, including Vehicles. CONTRACTOR will use Vehicles that are safe to operate, in accordance with the requirements promulgated by COUNTY Department of Public Health, California Highway Patrol, South Coast Air Quality Management District, manufacturer, and all other applicable Federal, State, County, and local laws and regulations. CONTRACTOR shall allow Director to view all inspection and maintenance Records and shall provide Director with those Records upon request.

CONTRACTOR is not required to provide new Vehicles on the Commencement Date or to retire Vehicles of any specified age. However, CONTRACTOR shall not operate Vehicles that repeatedly breakdown or leak. CONTRACTOR shall replace a Vehicle that Director determines to be of unsatisfactory operating condition, such as one that is frequently breaking

down and delaying services, leaking fluids, making noise, or exhibiting other significant issues identified by Director.

6. Vehicle List

CONTRACTOR shall use only Vehicles that have been submitted to and approved by Director. CONTRACTOR shall submit a complete list of Vehicles, including back-up Vehicles, using Form V, accessible through Director's Solid Waste Information Management System (SWIMS) and update it as Vehicles change.

7. Vehicle Billboards

CONTRACTOR shall equip automated Collection Vehicles with frames on both sides capable of securing signs measuring approximately 30 inches by 90 inches or another dimension approved by Director. CONTRACTOR shall design, print, and install signs on each frame promoting Recycling, Diversion and safe handling of Unpermitted Waste or other topics as requested by Director, with text, graphics, and design approved by Director, up to six times throughout the CONTRACT term. CONTRACTOR shall ensure that the appropriate Director-approved signs are affixed to the Vehicle always. Director reserves the right to interchange any of the six signs up to four times per Contract Year. CONTRACTOR shall not use the billboards for commercial advertising. Item B3 of Exhibit 16 includes examples of sign designs.

8. Company Name

CONTRACTOR's name or other name, as approved by Director, and logo shall appear on all Vehicles.

9. Vehicle Monitoring

In all Vehicles used for Task 1 Services CONTRACTOR shall install devices to monitor Vehicles' operations, including Global Positioning Systems (GPS) that record Vehicle's route and at a minimum, a camera on the Vehicle's dashboard, unless Director consents otherwise.

CONTRACTOR's failure to provide Reports requested by Director within time specified by Director may be considered an admission of fault for the purposes of assessing Liquidated Damages. For example, if CONTRACTOR does not give Director a requested Report, within a period specified by Director, to verify that a Vehicle Collected all Containers on an identified block, Director may assume that CONTRACTOR did not Collect those Containers and assess Liquidated Damages.

a. Video Equipment

CONTRACTOR's automated Collection Vehicles shall be equipped with functioning, forward facing, or angled slightly to the right, video recording equipment to validate service complaints such as missed Collections and other items that may be of interest to Director.

Video equipment must be recording once a Vehicle leaves the yard during days of operation. Video must be geotagged for location, time/date stamped, and at a resolution adequate to clearly identify the location being serviced and typically not less than 1280 x 720 at 30 frames per second with a viewing angle approximately 129° diagonal, 103° horizontal, 77° vertical. CONTRACTOR shall retain all videos in an electronic format for a minimum of 14 calendar days, or other duration as requested by Director. CONTRACTOR shall provide copies of videos and/or screen captures of a specific day, time, or for a specific location, within 48 hours of receiving Director request.

b. Global Positioning System (GPS)

GPS data will be maintained by CONTRACTOR either directly or through a third-Party service. The GPS shall be able to track a Vehicle's route with lines or dots superimposed on a map.

The GPS shall gather the following data: date, time, speed, direction, location (address) and shall be able to generate Reports. CONTRACTOR shall retain all data for a minimum of 14 calendar days or other duration approved by Director. CONTRACTOR shall provide copies of Reports within two business days of receiving Director request. Request may be for a specific time or a geographic location (between 10 a.m. and 11 a.m., or 1200 block of Main St.).

The minimum locate schedule (ping frequency of occurrence that GPS data is received from the Vehicle) shall be at least every one minute for fully automated Collection and at least every ten seconds for other Collection Vehicles, when within the Service Area.

10. Special Vehicles

See Exhibit 3A3 for possible special Vehicle requirements in this Service Area. This is likely only for areas with significant mountainous terrain.

F. Solid Waste Transportation, Processing, Diversion, and Disposal

CONTRACTOR-Designated Solid Waste Facility. CONTRACTOR shall transport Solid Waste only to the Solid Waste Facility or Facilities that CONTRACTOR has designated in Contractor Documentation in Exhibit 3D for

Processing, Diversion, or Disposal. CONTRACTOR may designate a Solid Waste Facility or Facilities that utilizes Conversion Technology or provides feedstock to Conversion Technology facilities. Prior to any change in designated facilities, CONTRACTOR must provide Notification to Director for consent of change. Director will review information such as fees, distance, Recycling rates, ability to Recycle Recyclables. Director may conditionally approve taking Solid Waste to a facility that charges more by not allowing the increased cost to be passed down to the Customer.

Director reserves the right to direct Solid Waste to a specific site or facility upon CONTRACT with CONTRACTOR. COUNTY will compensate CONTRACTOR for any direct costs, if any, such as increased tipping fees and transportation costs which CONTRACTOR incurs following delivery of materials to a COUNTY-designated Solid Waste Facility instead of to a CONTRACTOR-selected Solid Waste Facility.

Some Service Areas may require CONTRACTOR to use specific sites or facilities without additional compensation, as designated in Exhibit 3A3 if applicable to this CONTRACT.

G. Recyclables

1. Scavenging - Discouragement

CONTRACTOR shall use Reasonable Business Efforts to enforce the "Collection by Unauthorized Persons" law, pursuant to Public Resources Code Section 41950, et seq., and County Code Chapter 20.72.196 "anti-scavenging laws", including the following:

Marking Recyclables Containers with language that the materials are to only be picked up by CONTRACTOR as the "authorized agent" and that CONTRACTOR is picking up the material for Recycling purposes.

Orally advising any Person, other than CONTRACTOR, observed removing recyclable materials which have been segregated from Solid Waste materials and placed at a designated Collection location for the purposes of Collection and Recycling that such conduct is a misdemeanor, per COUNTY Ordinance, and carries civil penalties.

Instituting civil actions against a Person alleged to have violated California Public Resources Code Section 41950 for treble damages, as measured by the value of the material removed, or a civil penalty of not more than \$2,000, whichever is greater, for each unauthorized removal, in accordance with California Public Resources Code Section 41953(a);

Instituting civil actions against a Person alleged to have violated California Public Resources Code Section 41950 for a second, or subsequent time in a 12-month period, for treble damages, as measured by the value of the

material removed, or a civil penalty of not more than \$5,000, whichever is greater, for each unauthorized removal, in accordance with California Public Resources Code Section 41953(b); and

Taking actions under County Code Section 20.72.196 to discourage Scavenging.

2. Prohibition on Mixing Recyclables, Green Waste, and Refuse

Unless CONTRACTOR is obligated under this CONTRACT or approved by Director to conduct a single-pass for certain Occupants per Section 4B (such as on a private road) to Process Refuse for recovery of Recyclables, or unless as otherwise approved by Director, CONTRACTOR shall not:

- a. *Mix the contents Collected from Recyclables, Green Waste, and Refuse Containers; or*
- b. *Dispose of Recyclables or Green Waste Collected, except for:*
 - (1) Incidental amounts of Recyclables or Green Waste that an Occupant commingles with discarded Refuse;
 - (2) Green Waste used as alternate daily cover that is considered Diversion; or
 - (3) Contaminated Recyclables or Green Waste that cannot be Diverted using Reasonable Business Efforts if CONTRACTOR has previously exercised Reasonable Business Efforts to provide Occupant education with respect to reducing that contamination.

3. Residuals

a. Minimize Quantity of Residuals

CONTRACTOR shall not produce a significant quantity of Solid Waste residuals remaining after Processing Recyclables as determined by Director, including considering operating and recovery efficiencies and maximum levels of residuals that CalRecycle may establish to qualify the Processing as Diversion.

b. Maximize Diversion of Residuals

CONTRACTOR shall use Reasonable Business Efforts to Divert residual Solid Waste remaining after Processing Recyclables.

4. Diversion of Recyclables

CONTRACTOR shall Divert all Recyclables whether Diversion is a net cost or profit.

5. Recyclable Materials

- Aluminum and metal cans;
- Newspaper;
- Glass jars and bottles;
- Tin cans;
- Plastic soda bottles;
- Plastic milk and water jugs;
- Plastic bags (e.g., bread, frozen food, grocery bags);
- Type No. 1 plastic containers (PET-polyethylene terephthalate);
- Type No. 2 plastic containers (HDPE-high density polyethylene);
- Type No. 3 plastic (PVC-Vinyl or Polyvinyl Chloride);
- Type No. 4 plastic (LDPE-Low Density Polyethylene);
- Type No. 5 plastic (PP-Polypropylene);
- All types of paper (e.g., office paper, junk mail, magazines);
- Corrugated cardboard;
- White goods (such as those listed in the definition of Bulky Item);
- Paper coated with plastic or aluminum foil (milk and juice cartons);
- Mattresses, excluding those made mostly of foam.

6. Changes in Materials

Director may add or delete materials from Item 5 of the previous section to the list upon Notice to CONTRACTOR. Within 14 days of receiving that Notice, CONTRACTOR shall give Director a draft Notice informing Customers of changes in materials. Following COUNTY's approval, CONTRACTOR shall distribute those Notices to Customers and Occupants in the manner that Director requests in accordance with Item K4b of this Exhibit.

CONTRACTOR may request an adjustment to the Service Fee under item B1 of Exhibit 7, Change in Contract Services, including submission of documentation supporting the adjustment, to the Director. COUNTY and CONTRACTOR must agree on the adjustment.

Examples of adjustments (or no adjustments) might be:

- No Adjustment
- No incremental or net cost of Collection or Processing.
- Possible Adjustment
 - Incremental cost of acquiring new Containers, establishing additional Set-Out Sites, and adding an additional Collection route, not offset by materials sales.
 - Additional cost to Process material.

H. Special Services

CONTRACTOR shall provide the services prescribed in this Section without additional cost to Customers or charge to COUNTY except for subsection E of this Exhibit, Additional On-Call Pickup with Additional Cost.

1. Holiday Tree Collection

For a minimum of three weeks following December 25, or another period established by Director, CONTRACTOR shall Collect, transport, process, and Divert all Holiday trees, such as Christmas trees and Hanukkah bushes stripped of ornaments, garlands, tinsel, flocking, and stands, placed for Collection at the Set-Out Site, on the Occupant's regularly scheduled Collection day. All materials Collected shall be Recycled to the maximum extent feasible.

2. Annual Curbside Cleanup Event

Once each Calendar Year, CONTRACTOR shall Collect up to 20 Bulky Item or bagged/bundled Excess Solid Waste, discarded at each Set-Out Site by the Occupant, including Construction and Demolition debris which is limited to two 70-pound bags, containers, or bundles. Any Construction and Demolition debris or other items not Collected shall be tagged with a Non-Collection Notice explaining the reason for it not being removed.

CONTRACTOR shall use Reasonable Business Efforts to ensure that this event is held the same weekends as previous year and no changes shall be made without Director's approval. See item C of Exhibit 3A3 for months or dates of previous year's events. CONTRACTOR shall schedule events in succeeding Saturdays assigning one Service Day for each Saturday, except on a Holiday weekend and the following weekend if Collection service was delayed and Friday service is now on Saturday. CONTRACTOR shall avoid Holiday weekends and other weekends with celebrations or parades. Multiple Service Days may be combined into one Saturday upon approval by Director.

CONTRACTOR shall provide Director with information regarding the event such as route maps with starting and ending points, primary contact Person, and other information requested by Director one week prior to the day of each event.

CONTRACTOR shall instruct Occupants to place their items at the Set-Out Site prior to 6 a.m. of the day of their event. CONTRACTOR shall start the event no earlier than 6 a.m. and end by 6 p.m. on the Saturdays during the event, or as instructed by Director.

CONTRACTOR is to anticipate that some Occupants will place items at the Set-Out Site after 6 a.m. and after CONTRACTOR has passed that

Occupant's home. Therefore, prior to the end of each day's event, CONTRACTOR shall return to each street one time to ensure that all discarded materials placed at Set-Out Site were Collected. CONTRACTOR is not required to use a Collection Vehicle for the second pass. For example, CONTRACTOR's route supervisor may check the Set-Out Sites. If any discarded material is found, CONTRACTOR shall Collect it that same day. Any items in the Public Right-of-Way after CONTRACTOR has returned one time are considered Abandoned Waste.

CONTRACTOR may be required, upon oral or text message request of Director to return to any event route and Collect discarded materials left out at the Set-Out Site. This shall be accomplished on the same day of the request. If Director makes such a request, it shall not be considered a violation of the service hours.

3. Bulky Item and Excess Solid Waste Collection

In addition to the Annual Curbside Cleanup Event described in item H2 of this Exhibit, CONTRACTOR shall Collect Bulky Items and Excess Solid Waste discarded at the Set-Out Site as specified in item B of Exhibit 3A3.

4. Priority Pickups at Director's Request

Each Calendar Year, CONTRACTOR shall Collect unlimited amounts of Solid Waste Discarded in the Public Right-of-Way according to circumstances below.

a. End of Next Service Day

20 times by the end of the next Service Day after Director's request or other time agreed to between Director and CONTRACTOR.

b. Same Day

10 times on the same day of Director's request.

5. Special Cleanup Events Services

At Director's request, CONTRACTOR shall provide Containers such as roll-offs, Bins, Carts, Dumpsters, Cardboard boxes in type, number, and capacity (up to 80 cubic yards) for discards of Solid Waste at up to six community cleanup projects or public events located throughout the Service Area during any 12-month period. CONTRACTOR may be required to replace filled Containers during the event if directed to do so by Director prior to the event and shall be responsible for removing any Refuse that is left alongside of, rather than inside, the Containers. CONTRACTOR shall Collect Containers at the end of the event, the next day, or other date agreed to between Director and CONTRACTOR. Event participants will be

instructed to gather bags into piles at the end of the event. CONTRACTOR shall provide all the necessary staffing, labor, Vehicles, Containers, and other equipment, and materials or supplies (such as plastic bags in portable containers).

6. Sharps Collection

Within one week of a Customer or Occupant request, CONTRACTOR shall provide the Occupant, without charge, with the following:

a. *Four Sharps Containers per Year*

A Sharps Container that has at least a one-gallon capacity (up to four per Contract Year) for discard of Sharps in accordance with any Federal, State, and local laws and regulations; and,

b. *Collect or Pre-Paid Mailer*

CONTRACTOR shall also Collect Sharps Container or provide a prepaid postage container for mailing back the approved Sharps Container in accordance with any Federal, State, and local laws and regulations.

CONTRACTOR shall Collect, transport, and Dispose of materials, without charge, in accordance with any Federal, State, and local laws and regulations.

7. Mulch and Compost Giveaway Program

CONTRACTOR shall twice annually, publicize and offer Occupants Mulch (i.e., shredded bark and wood chips) and Compost (no tire shreds) at no additional charge to Customers, Occupants, or COUNTY. This shall occur once in the early Spring and again in the early Fall, or at alternate dates as requested or approved by Director. CONTRACTOR shall and use Reasonable Business Efforts to offer Mulch and Compost that were produced from Green Waste generated in the Service Area.

See item A of Exhibit 3A3 for required minimum quantities of Mulch and Compost. CONTRACTOR shall comply with the California Department of Food and Agriculture's quarantine restrictions for the movement of the Green Waste. (<https://www.cdfa.ca.gov/plant/pe/InteriorExclusion/quarantine.html>)

a. *Pickup Event*

CONTRACTOR shall select a location, preferably within the Service Area (typically in the parking lot of a park or school) or other feasible areas approved by Director and shall be responsible for planning and making all necessary arrangements. CONTRACTOR shall provide

all the necessary staffing, Vehicles, Containers, and other equipment, and materials or supplies (such as shovels and extra bags). CONTRACTOR shall help participants who request help and shall post a bilingual at the event offering assistance. Upon request of CONTRACTOR, Director may provide some assistance in securing COUNTY facilities.

b. Delivery

In lieu of a pickup event, CONTRACTOR may deliver bagged Mulch and Compost, with Director approval. CONTRACTOR shall provide all the necessary staffing, Vehicles, and bags. Within one week after Occupant request, CONTRACTOR shall deliver Mulch and/or Compost to that Occupant's address.

8. Director's Fund

Each Contract Year, CONTRACTOR shall create and maintain a fund for use upon Director's request for as-needed tasks similar in nature or related to Contract Services (Task 1 and Task 2 Services). The amount of this fund shall be calculated based on the number of parcels at the rate of \$0.09 per parcel per month per year and shall be available for use at the Director's request after the Commencement Date. Parcel counts are based on the number of parcels on the Commencement Date and adjusted annually thereafter. Unused funds shall rollover to the next Contract Year. For example, 5,000 parcels would generate a fund of $\$0.09 \times 5,000 \times 12 = \$5,400$ every year.

Examples of use of this fund are as follows:

- Power washing of street, alley, or sidewalk
- Washing Containers
- Printing brochures or flyers
- Mailings to Service Area
- Ordering of promotional items (reusable bags, pencils, magnets, etc.)
- Rollout service, including Collection of a Bulky Item from near the front door of a Residential Premises

I. Roll-Out Services for Containers

CONTRACTOR shall provide manual Container roll-out for all or a portion of Collection at the request of any Customer for the charge in Attachment 7-2, Task 1 Service Fees of Exhibit 7, without additional charge for Elderly or Disabled Occupants. Elderly or Disabled Occupants must certify to CONTRACTOR that there is no able-bodied individual in the household who can move the Cart to the Set-Out Site. The roll-out service may be any one of the three services described below.

Subject to Director review and approval and further subject to CONTRACTOR'S obligations under Part 9C of Exhibit 5, CONTRACTOR may require those Customers and Occupants who subscribe to roll-out services to sign an agreement containing an indemnification of CONTRACTOR and COUNTY, for any claim related to, or arising from the roll-out service, other than the sole negligence of the indemnified party.

1. Full Service (Up to 50 feet) Carts

This service is for a typical urban Single-Family Home, or similar, to move the Carts from near the home, to the street, and back again. The roll-out shall be on paved, relatively flat surfaces at a distance up to approximately 50 feet from the Set-Out Site to the Occupant's on-site storage location, measured along the route the Container must travel. This service shall be for the charge in Attachment 7-2, Task 1 Service Fees of Exhibit 7.

These services include the following:

a. *Move Carts*

Moving Carts from their storage location to the Collection Vehicle and returning them to their storage location. CONTRACTOR shall not leave Carts left in the street for more than one hour; and

b. *Carry Bulky Items*

Carrying Bulky Items or E-waste from outside, adjacent to a building out to the curb that was called in for Collection by Customer or Occupant. CONTRACTOR shall not be required to remove Bulky Items or E-waste from inside a residence or business.

2. Extended Full-Service Carts

This service is the same as the services in item 1, Full Service in this Section but with either of the extenuating circumstances below for the charge in Attachment 7-2, Task 1 Service Fees of Exhibit 7.

a. *Long Driveways.*

Driveways longer than 50 feet of distance between the Set-Out Site and the Occupant's on-site storage location. There will be an additional fee equal to the full-service fee in item 1 of this section, for every 200 feet of driveway.

b. *Unpaved Driveways*

Conditions of the property such as the surface of the driveway is unpaved, prevents one Person from easily or safely rolling the Cart or requires two people from safely carry a Bulky Item. There will be a surcharge of 10 percent increase to the roll-out fee for an unpaved driveway.

c. *Steep Driveways*

Conditions of the property such as the surface of the driveway is very steep (25 percent grade, 2.5 feet rise over 10 feet), prevents one Person from easily or safely rolling the Cart or requires two people from safely carry a Bulky Item. There will be a surcharge of 10 percent increase to the roll-out fee for a steep driveway.

3. Minimum Service (Up to Ten feet) Carts

This service is like item 1, Full Service in this Section but for areas with Set-Out Site limitations and a distance up to approximately ten feet between the Set-Out Site and the location Occupant places the Containers. See Exhibit 3A3 for possible additional details.

This service may be used in circumstances where it is unsafe to place the Containers in the road for extended periods due to bicycle paths, dense parking, narrow streets, animals, or other reasons.

4. Dumpsters

CONTRACTOR shall provide manual Dumpster roll-out for all or a portion of Collection at the request of any Multifamily or Commercial Customer or Occupants at no extra charge.

J. Method of Payment for Task 1 Services

For Customer Services, CONTRACTOR shall bill COUNTY directly for Customer's Basic Services and bill Customers directly for any Additional Customer Services, in accordance with Section 7.

For County Services, CONTRACTOR shall bill COUNTY directly, in accordance with Section 7.

K. Transition Roll-Out Plan

At least 30 days Prior to the Execution Date, CONTRACTOR shall provide to Director for approval a start-up transition and Container roll-out plan, including both time line and tasks. CONTRACTOR shall submit a plan in accordance with item B19 of Exhibit 3D, and shall address items such as:

- Ordering Vehicles and/or Containers;
- Vehicle and/or Container delivery from manufacturer;
- Container assembly;
- Distributing Containers to Customers and Occupants;
- Public outreach and education activities;
- Determining routes;
- Training route drivers;
- Collecting old Containers; and
- Commencement Date of Collection.

CONTRACTOR shall implement the approved start-up transition roll-out plan for an orderly transition of Refuse services from one contractor to another.

CONTRACTOR shall cooperate and work with outgoing and future contractor of Task 1 Services to ensure a smooth transition. CONTRACTOR shall agree that if necessary for the orderly transition of Collection services to:

- Collect Solid Waste from outgoing CONTRACTOR's Containers;
- Allow outgoing CONTRACTOR to Collect from Containers;
- Service, remove, and store outgoing contractor's Containers after transition;
- Allow future CONTRACTOR to Collect from Containers after the termination of CONTRACT; and
- Continue Occupant's services, Container quantity and sizes, and discounts from outgoing CONTRACTOR's customer service list, including not providing Containers to addresses not utilizing outgoing CONTRACTOR's services.

Director shall have the final say to require transition services agreement between outgoing CONTRACTOR and future contractor.

L. Public Education and Outreach

CONTRACTOR shall develop, disseminate, and conduct comprehensive public education and outreach regarding services to maximize Diversion of Recyclables, Green Waste, Bulky items, Sharps, and E-waste. The public education and outreach components shall include but not be limited to the following:

1. Customer Terms and Conditions

Before commencing Task 1 Services and annually thereafter by July 1, CONTRACTOR shall provide a Terms and Conditions to Customers and Occupants, substantially in the form included in Exhibit 16 and approved by Director.

CONTRACTOR shall distribute to Customers and Occupants a copy of the Terms and Conditions upon request.

Director may change the form and content of Terms and Conditions from time to time after Notice to CONTRACTOR. CONTRACTOR may change the form of Terms and Conditions only with Director's prior written consent in accordance with item L1.

2. Service Brochure(s)

Before commencing Task 1 Services and to each new Customer and Occupant, and annually throughout the CONTRACT term, CONTRACTOR shall provide a service brochure to Customers and Occupants, specifically in the form included in item D of Exhibit 16, which must include at a minimum, all the following items:

- The scope of Task 1 Services, including general information on size and number of Carts, where to get specific information about their Containers, and a general description of the Set-Out Site;
- Holiday schedules in accordance with item B5 of Exhibit 3A1;
- Delivery, pick up, exchange, and replacement of Carts;
- Any weight limitations of Carts;
- CONTRACTOR's Office Hours, toll-free customer service telephone number, e-mail address, and website;
- Director's telephone number (888 CleanLA), which the Customers or Occupants may call after contacting CONTRACTOR if the Customer's or Occupant's service complaint is not satisfactorily resolved;
- Description of Green Waste and items (such as palm fronds) that do not comprise Green Waste, including items approved by Director;
- Description of the Recyclables; and
- Any other information requested by Director.

3. Community Meetings/Events

a. *Prior to Start of Contract*

Before beginning Task 1 Services, CONTRACTOR shall hold a minimum of two and up to six community meetings to explain hauler transition, if applicable, and new Task 1 Services to Customers and Occupants in the Service Area:

- Up to three on weekday evenings;
- Up to three on separate Saturdays; and
- Director may modify number, date, and time.

CONTRACTOR shall inform Director of the proposed meeting locations, setup, and arrangements at least three weeks prior to the proposed date. CONTRACTOR shall obtain Director's approval before holding any meeting.

CONTRACTOR shall notify all Customers and Occupants of the purpose, time, and place of each meeting at least two weeks prior to the scheduled community meetings. CONTRACTOR shall notify Customers and Occupants as set forth under item L4b(4) of this Exhibit. CONTRACTOR shall use address list provided by Director or a Director approved list provided by the previous contractor.

b. *Upon Director Request*

CONTRACTOR shall attend up to 20 community meetings/events per Contract Year upon Director's request. Examples include local fairs or civic events with individuals, Customers and Occupants, community organizations, city councils, town councils and any other groups named by Director. CONTRACTOR shall take any or all the following actions at the meetings/events, approved by Director:

(1) Operate Recycling Information Booths

CONTRACTOR shall operate Recycling information booths and distribute colorful flyers, promotional items, have a minimum of 100 CONTRACTOR-provided reusable bags available, pamphlets, and other items that encourage participants to Recycle, reduce, reuse, and/or Divert Solid Waste.

Additionally, upon Director request, CONTRACTOR shall order and provide up to \$500 worth of miscellaneous promotional items such as miniature recyclables carts or magnets per Contract Year. Director may request that CONTRACTOR give out these items at a specific event or Director may distribute these items at any events.

(2) Other Activities/Actions

CONTRACTOR shall conduct other similar activities and take other similar actions requested by Director.

4. Written Notices and Outreach Materials

a. *Prior to Beginning Task 1 Services*

(1) Letter From Director

Within 30 days after the Award Date or other date designated by Director, CONTRACTOR shall print and mail letters written by Director, notifying Customers and Occupants that the CONTRACT was awarded to CONTRACTOR.

CONTRACTOR shall be responsible to pay for the cost of producing and mailing these letters.

(2) Letter From CONTRACTOR

Within 60 days prior to the Commencement Date or other date designated by Director, CONTRACTOR shall prepare and mail a letter to all Customers and Occupants introducing themselves, explaining the transition, and announcing upcoming community meeting dates, and other pertinent information.

b. Upon Start of Task 1 Services and Annually

CONTRACTOR shall develop written educational materials and deliver them to Customers and Occupants. Historically this information was distributed using quarterly newsletters. To reach more people and reduce paper waste, it is desired to use new methodology to take advantage of technology, such as smartphones. Customers and Occupants are to be given a choice of how they want to receive the information, through traditional quarterly newsletters or via "monthly" text or e-mail messages. Such educational materials include:

(1) Articles

A minimum of four times and up to eight times per Contract Year, CONTRACTOR shall develop a bilingual article with color graphics containing information that encourages Recycling and to educate Customers and Occupants of Task 1 Services available under this CONTRACT. Director may provide sample articles. Topics include the following examples:

- Placement of Carts including during heavy rains
- Holiday Tree Collection instructions
- Organics and/or Green Waste
- Bulky Items
- Illegal dumping
- Annual Curbside Cleanup Event Promotion
- Cleaning Containers
- Commingling of Solid Wastes
- 4 R's, reduce reuse Recycle rethink
- Carts left in street
- Unpermitted Waste Disposal
- New Solid Waste laws
- Articles specific to Service Area, such as bear Carts, palm fronds, or Manure
- Other articles upon the request of Director

(2) Special Announcements

CONTRACTOR shall develop and deliver, as set forth in item L4b(4) of this Exhibit, outreach Notices to Customers and Occupants on various events, upon receiving approval from Director, including and not limited to:

- Household Hazardous Waste Collection Events
- Annual Curbside Cleanup Event schedule
- Compost/Mulch Giveaway Event
- Smart Gardening Workshops
- Holiday Collection schedule
- Billing reminders, upon Customer request*
- Service interruptions*
- Non-Collection Notice*
- Sharps pickup
- Other Notices upon the request of Director

* These are limited to text or e-mail messages and are not applicable to newsletters.

CONTRACTOR shall give between two and three weeks of events, or other time, as requested by Director, notice of each announcement to Customers and Occupants, except as related to billing reminders, service interruptions, and Non-Collection Notices. Upon Director's request, CONTRACTOR shall use artwork, layout, or notices, provided by Director.

(3) Distribution

The articles and announcements will be disseminated in the following ways, as requested by Customers and Occupants:

(a) Newsletters

CONTRACTOR shall develop one-page (additional page(s) for Spanish, if required by Director) newsletters in color containing information upon receiving approval from COUNTY, CONTRACTOR shall deliver these newsletters to Customers and Occupants four times each Contract Year. Newsletters shall be available in electronic format such as PDF. CONTRACTOR shall make newsletters for 8.5-inch by 11-inches or 8.5-inch by 14-inch sized paper, whichever is appropriate, as requested by Director.

Once per year, Director may request a second English page be added to newsletter.

(b) E-mail/Text Messages.

CONTRACTOR shall send brief electronic messages containing links to full articles, upcoming events, and/or newsletters for Customers and Occupants who request them. For example, in late December send a text worded, "Have a Holiday tree to get rid of? [Click here.](#)", with a link to an article about Holiday trees. When there is an HHW Collection Event nearby, send a text worded, "Leftover household chemicals, paint, or used oil to get rid of? [Click here.](#)" Messages shall be sent approximately monthly plus special announcements as necessary.

(4) **Delivery of Written Materials to Customers and Occupants**

CONTRACTOR shall deliver general materials, such as Notices and newsletters, Customers and Occupants by any or all the following means approved by Director:

- U.S. Postal Service;
- Door-to-door delivery service;
- Insert in monthly Customer bills*;
- Electronic mail (E-mail)*;
- Text messages*;
- Other means approved by Director

* These methods individually are not adequate.

CONTRACTOR shall include Director in their mailing list and ensure that general materials are sent to Director the same time they are sent out to the Customers and Occupants.

CONTRACTOR shall submit proof of mailing within 7 days of mailing.

(5) **Social Media**

CONTRACTOR shall reach out to Customers and Occupants and make information available regarding Task 1 Services by current social media and the following means approved by Director, such as: Facebook, Twitter, Instagram.

5. Additional Outreach

CONTRACTOR shall visit in-person, call, send an e-mail or text, or other means to inform a Customer or Occupant of services or issues, as requested by Director. For example, CONTRACTOR shall speak to an Occupant that contaminates a Container or frequently leaves a Bulky Item at the Set-Out Site without calling to request Collection.

6. Bilingual Correspondence

CONTRACTOR shall develop all written materials in both English and Spanish, if required by Director.

7. Outreach to Commercial Franchise Multi-Family and Business Accounts

As less Refuse is generated through waste reduction or Diversion practices, smaller volume Refuse Carts may be an option that Dumpster users may not have previously considered.

Upon Director request, CONTRACTOR shall visit in-person or mail Dumpster Customers to inform them of the option to use Carts through this CONTRACT, within 30 days of Commencement Date and annually thereafter. Director will provide an address list. Director approval is required for all written materials. Written materials shall consist of a letter and a color brochure with inserts.

While this service is not likely to be requested by Director at the beginning of the Contract, it may be requested later.

M. CONTRACTOR Commitments Made in Proposal

CONTRACTOR shall fully and timely satisfy any additional Performance Obligations set forth in item B18 of Exhibit 3D from its proposal to Director for procurement of this CONTRACT.

N. Additional Performance Obligations Specific to this Service Area

CONTRACTOR shall fully and timely satisfy any Performance Obligations specific to this Service Area that are listed in item 18 of item B of Exhibit 3D.

O. Difficult to Service

If CONTRACTOR is unable to Collect Refuse, Recyclables, Green Waste, and/or Green Waste with a standard automated Collection Vehicle, CONTRACTOR shall use an alternative size or type of Vehicle as necessary including manual or other form of Collection to ensure Task 1 Services. Additionally, CONTRACTOR may be able to use a standard Collection Vehicle but the rate of Collection is significantly slower. Areas that are difficult to service include those with narrow

streets, alleys and bridges, one-way narrow streets, steep roadway gradients, limited roadway curve radii (tight curve), thin pavement thicknesses, unimproved (dirt) roadway surfaces, and variable vertical and horizontal clearances.

A list of difficult to service addresses is in item C2 of Exhibit 16 and a map of the areas are in item A3 of Exhibit 16. The list is subject to change upon written notification by Director or upon request by CONTRACTOR and approval by Director. CONTRACTOR shall charge a difficult to service fee per rate schedule in Attachment 7-2, Task 1 Service Fees of Exhibit 7.

See Exhibit 3A3 for possible additional details.

P. Food Waste

This CONTRACT includes the Collection of Food Waste as part of the Refuse. However, it is anticipated that prior to the termination of this CONTRACT, COUNTY will have a desire to Divert Food Waste. At that time, COUNTY may choose to do any of the following:

- Negotiate with CONTRACTOR for a mutually agreed Customer fee to submit and implement a plan for approval and provide for the Collection, transportation, and Diversion of Organics, which may include comingled Food Waste with Green Waste, or
- Terminate CONTRACT if COUNTY and CONTRACTOR are unable to agree upon a fee for the service, or
- Keep CONTRACT with CONTRACTOR but solicit bids and authorize a new contract for the Collection, transportation, and Diversion of Food Waste.

**EXHIBIT 3A2 – Task 2 Services
Abandoned Waste Collection Services And
Public Receptacle Collection Services**

A. Abandoned Waste Collection, Transportation, and Diversion/Disposal

1. Service Locations and Times.

CONTRACTOR shall keep the Public Right-of-Way in the Service Area free of Abandoned Waste. The goal is to have any Abandoned Waste for as short of a time as possible, using Reasonable Business Efforts, but never more than seven calendar days. CONTRACTOR shall do all the following as further provided under this subsection, unless Director otherwise requires:

a. *Monitor*

CONTRACTOR shall monitor the Service Area for Abandoned Waste while providing all Contract Services, except for Hot Zones under subsection 5 which CONTRACTOR shall monitor daily. CONTRACTOR may use the drivers of its Refuse, Recyclables, and Green Waste Collection Vehicles; route supervisors, or a separate crew.

b. *Document*

CONTRACTOR is not required to provide evidence of Abandoned Waste removal except in the following events:

- Director's request
- CONTRACTOR, request for additional compensation.

CONTRACTOR shall provide the following evidence:

- **More Than Four Cubic Yards:** photos of the excess waste.
- **More Than Expected Incidents:** photos of the waste Collected at more than the expected incidents of pickups.

c. *Remove*

CONTRACTOR shall Collect, transport, and Divert or Dispose of all Abandoned Waste, in unlimited amounts, within the following times:

- On the same day as automated Collection specified in Task 1 Services, in item B4 of Exhibit 3A1, Sweep of the entire Service Area;
- By the end of the second Service Day after a request by Director or any Person;

- By the end of the next Service Day after observation by CONTRACTOR, or request by Director or any Person, for items blocking or hindering passage, or items posing a potential health and/or safety hazard;
- By the end of the next Service Day after Director's request for removal of Abandoned Waste at up to 20 locations each Calendar Year,
- By the end of the same Service Day of Director's request for removal of Abandoned Waste at up to five locations each Calendar Year,
- Within any other time agreed upon Director and CONTRACTOR.
- With respect to Hot Zones, within the time required under Subsection A5.

d. *Clean*

CONTRACTOR shall sweep or otherwise clean and Collect all loose litter and debris within three feet of an item of Abandoned Waste.

2. Miscellaneous Requirements

a. *Alternative Vehicles*

If obstacles impede the progress of Refuse Collection Vehicle such as low, hanging wires; protruding vegetation; and leaning fences, CONTRACTOR shall use alternative Vehicles and equipment.

b. *Unpermitted Wastes*

If CONTRACTOR identifies any Unpermitted Waste, CONTRACTOR shall immediately follow its Unpermitted Waste Protocol in accordance with item A of Section 13.

c. *Very Large Items*

If CONTRACTOR identifies any item of Abandoned Waste that is too large to Collect in its Refuse Collection Vehicles, it may ask Director for Road Maintenance Division's help.

d. *Comprehensive Service*

Service under this Section includes the furnishing of all labor, supervision, administration, material, and equipment.

3. **No Longer Used**

4. **Abandoned Waste and Litter in Alleys**

CONTRACTOR shall ensure that all alleys including but not limited to wall to wall and/or fence to fence within the Service Area are in a state of cleanliness.

If the Service Areas does not currently have any alleys requiring service, then the miles listed in item C1 of Exhibit 16 will be 0 or n/a. Director may add alleys.

5. **Daily Clean up in Hot Zones**

CONTRACTOR shall monitor, remove and clean up Abandoned Waste in Hot Zones daily, Monday through Friday (or the day after a Holiday) between the hours of 7 a.m. and 6 p.m. for the following locations:

- The locations of Hot Zone are shown in item A2 of Exhibit 16.
- If there are no Hot Zones, then the feet listed in item C2 of Exhibit 16 will be 0 or n/a. Examples of Hot Zones are areas where Abandoned Waste is dumped frequently, or areas Director deems important to keep free of Abandoned Waste.
- Director may amend item A2 and C1 of Exhibit 16 upon Notice to CONTRACTOR, including increasing the existing route length by up to 125 percent. Amendments are subject to agreement with CONTRACTOR on adjusting CONTRACTOR's compensation, except for the rate per foot which will not be adjusted.

6. **Payment**

COUNTY will pay CONTRACTOR the fee for monitoring and Collecting Abandoned Waste as provided in item C of Section 7, even though under County Code the cost of removing Abandoned Waste is the responsibility of the Person, if known, who discards the waste.

If CONTRACTOR believes that it knows the probable identity of the Person who discarded the Abandoned Waste, it shall take a photograph of the Abandoned Waste and discard site. CONTRACTOR shall send the photo to Director along with other information on which it bases its belief. Even if CONTRACTOR identifies who discarded the Abandoned Waste it must nevertheless Collect that Abandoned Waste under this Exhibit.

B. Public Curbside Receptacles Collection Service

The work to be accomplished shall include the furnishing of all labor, supervision, administration, material, and equipment for the clean-up, Collection, transportation, Diversion/Disposal, and management of discards from designated public curbside receptacles, in unlimited quantities, in the Service Area. Item C3 of Exhibit 16 contains a list of the number of receptacles and item A6 of Exhibit 16 contains a map of the locations.

1. Collection

CONTRACTOR shall Collect discards from public curbside receptacles by removing the plastic bag and its contents from the inner liner and replacing with a new plastic bag or removing the Refuse or Recyclables from the bag if there were only a few items inside. CONTRACTOR shall supply and its use own plastic bags. The public curbside receptacles are furnished by COUNTY, located along business districts with high pedestrian activity. A public receptacle may include one intended for pet waste. The quantities and locations of the applicable public curbside receptacles are identified on item A6 of Exhibit 16 and may be subject to change by Director.

2. Maintenance

As needed, CONTRACTOR shall also clean and wipe down the outside and liner of the public curbside receptacles as well as clean and Collect, all loose litter and debris, within three feet of the base of the public curbside receptacles, such as paper, bottles, cans, dirt, organic material, and other incidental litter. The standard of cleanliness shall be that no odors once waste is removed and no visible spills, stains, markings, dust, or dirt on the inside or outside of the receptacles. At a minimum, receptacles are to be cleaned every two weeks. CONTRACTOR shall carry on each truck, rags and hand tools such as rakes, shovels, and brooms to aid with the clean-up of incidental litter and debris.

CONTRACTOR shall notify Director of the presence of any graffiti or other markings that deface or detract from the aesthetic quality of the public receptacles. If the graffiti is comprised of obscenities, notification shall be within 24 hours.

If any plastic liner is damaged beyond repair, such liner shall be replaced at CONTRACTOR's expense.

3. Collection Schedule

a. *Standard Public Receptacles*

CONTRACTOR shall Collect discards from the non-compactor public curbside receptacles, twice per day, Monday through Saturday, with the first Collection occurring between the hours of 7 a.m. and 9 a.m., and the second Collection between the hours of 2 p.m. and 4 p.m. Director reserves the right to reduce the frequency of Collection throughout the Service Area at any time during the Term of this CONTRACT at the sole discretion of Director. See Exhibit 3A3 for possible modifications to the days or times.

b. *Solar Compacting Public Receptacles*

CONTRACTOR shall Collect discards from the solar compacting public curbside receptacles as-needed, Monday through Saturday, based on the need indicated on the Internet based monitoring software. The schedule shall not be more frequent than twice per day or longer than seven days for receptacles with Refuse.

4. Other

a. *Adjustments to Quantity and Location*

In the event the quantities, and locations of the public curbside receptacles or the type of Solid Waste discarded in those receptacles change during the Term of this CONTRACT, Director will notify CONTRACTOR of such change in writing. Collections from any additional public curbside receptacle or reduction in public curbside receptacles will be adjusted at the Annual Total identified on Attachment 7-3 Task 2 Service Fees but the rate for individual receptacles will not be adjusted. The number of receptacles over the Term may be increased by up to 125 percent of the current number, which includes doubling the number of receptacles at the time this CONTRACT is executed, to add Recycling plus 25 percent more for new locations.

CONTRACTOR will Collect Refuse in additional receptacles within two weeks of Director's request, subject to possible adjustment of the Service Fee for change orders under Section 3B.

If the Service Area does not have any designated public curbside receptacles as of the Execution Date, the number listed in item A6 of Exhibit 16 will be 0 or n/a.

b. *Solar Refuse/Recyclables compactors*

Director reserves the right to replace the current public curbside receptacles with solar Refuse/Recyclables compactors. In the event the current receptacles are replaced, the cost for servicing and maintaining cleanliness of each compactor shall remain the same as the current cost for servicing each public curbside receptacle.

c. *Verification*

If the public receptacles have a service log sheet inside, CONTRACTOR must sign, date, and record the time of Collection service or indicate the receptacle was empty upon inspection and record when the receptacle was cleaned.

d. *Receptacle Locks*

CONTRACTOR shall keep all receptacles locked to prevent access by the public. Director shall furnish keys.

e. *Damaged Receptacles*

CONTRACTOR shall report damage to the receptacles with 48 hours of observing such damage. Damage includes but is not limited to missing components or malfunctioning parts. CONTRACTOR shall not attempt to repair any receptacles, except for plastic liners. Liners are CONTRACTOR's responsibility to repair or replace regardless of the cause of damage.

f. *Recyclables*

As of the Execution Date designated public curbside receptacles in the Service Area primarily contain Refuse. CONTRACTOR will Collect and Divert Recyclables discarded in existing or additional Recyclable receptacles within two weeks of Director's request, subject to possible adjustment of the Service Fee for change orders under Section 3B.

C. *Abandoned Cart, Dumpster, or Roll-Off Removal*

At the request of Director, CONTRACTOR shall, at no charge to COUNTY:

- Remove any container, including cans, Carts, Dumpsters and roll-off bins that COUNTY deems abandoned, within two Service Days, whether they are CONTRACTOR's Containers or third Parties'.
- Arrange for the Disposal or Diversion of Solid Waste within the container.

- Reuse, Recycle, or resell container.
- Notify Director to confirm removal.

D. Vehicles

1. General

CONTRACTOR shall be responsible for providing all Vehicles of appropriate sizes, capacities, and functions required for the Collection of Solid Waste and for ancillary services that are sufficient in number and capacity to efficiently perform the work required by this CONTRACT. CONTRACTOR shall also be required to provide non-compacting Vehicles for the Collection of E-waste and white goods, which may contain chlorofluorocarbons. Vehicles shall be so constructed such that Solid Waste or liquids will not blow, fall, sift, or leak out of the truck into the street and shall be equipped with an adequate shovel, broom, and petroleum absorbent agents.

2. Fuel/Power

Vehicles used for Collection must use LNG (liquid natural gas) or CNG (compressed natural gas) fuel, or other alternatives to diesel fuel, as approved by Director unless Contractor Documentation provides otherwise with respect to Collection at Premises that are difficult to service as permitted in item O.

3. Extra Vehicles

CONTRACTOR shall have available sufficient back-up Vehicles for each type of Collection Vehicle used to respond to breakdowns, complaints, and emergencies. Director may specify a minimum level of backup equipment required.

4. Maintenance

CONTRACTOR Vehicles used in the Service Area shall, always, be kept reasonably clean, in good mechanical condition, and well painted, all to the satisfaction of Director. CONTRACTOR shall maintain Records of inspections and maintenance of all mechanical equipment used in providing the required services in the Service Area to ensure that all Collection Vehicles are safe to operate within the Service Area at all times in accordance with the requirements promulgated by COUNTY Department of Public Health, California Highway Patrol, South Coast Air Quality Management District, manufacturer, and all other applicable Federal, State, County, and local laws and regulations. All inspection and maintenance Records shall be open to inspection by Director and provided upon request. CONTRACTOR shall replace a Vehicle that Director determines to be of

unsatisfactory operating condition such as one that is experiencing excessive breakdowns resulting in service delays, leaking fluids, or other significant issues.

5. Vehicle List

Only those Vehicles submitted to and approved by Director shall be used in the Service Area. CONTRACTOR shall submit a complete list of Vehicles using Form V, accessible through Director's Solid Waste Information Management System (SWIMS) and update it as Vehicles change. Extra Vehicles intended as a backup shall be included.

6. Company Name

CONTRACTOR's name or other name, as approved by Director, and logo shall appear on all Vehicles.

7. Vehicle Monitoring

CONTRACTOR shall utilize appropriate technologies (software and hardware) to meet Director's requirements for field operations location reporting. All Vehicles used for Collection for Task 2 Services (abandoned waste, public receptacles, etc.) shall be equipped with data recording capabilities to capture video and route data from global positioning system (GPS) devices. There are inexpensive consumer dashboard cameras on the market that will record video and GPS location to meet this requirement. The use of any Vehicles to Collect Solid Waste without monitoring equipment requires Director's consent.

Failing to provide requested Reports for any reason will be considered an admission of guilt for the purposes of investigating CONTRACT service commitments. For example, if Director requests a Report to verify Collection occurred on a certain block, Director will have no way of knowing if CONTRACTOR intentionally deleted data to not incriminate themselves and therefore, the block will be considered not serviced if documentation is not provided and the action will be subject to Liquidated Damages both the failed Collection and for failure to submit the requested Report.

a. Video Equipment

CONTRACTOR's automated Collection Vehicles shall be equipped with functioning, forward facing, or angled slightly to the right, video recording equipment to validate service complaints such as missed collections, alley cleaning, and other items that may be of interest to Director.

Video equipment must be recording once a Vehicle leaves the yard during days of operation. Video must be geotagged for location, time/date stamped, and at a resolution adequate to clearly identify the location being serviced and typically not less than 1280 x 720 at 30 frames per second with a viewing angle approximately 129° diagonal, 103° horizontal, 77° vertical. CONTRACTOR shall retain all videos in an electronic format for a minimum of 14 calendar days, or other duration as requested by Director. CONTRACTOR shall provide copies of videos and/or screen captures of a specific day, time, or for a specific location, within 48 hours of receiving Director request.

b. *Global Positioning System (GPS)*

This data will be maintained by CONTRACTOR either directly or through a third-Party service. The GPS shall track a Vehicle's route with lines or dots superimposed on a map.

The GPS shall gather the following data: date, time, speed, direction, location (address) and shall generate Reports. CONTRACTOR shall retain all data for a minimum of 12 calendar months or other duration approved by Director. CONTRACTOR shall provide copies of Reports within two business days of receiving Director request. Request may be for a specific time or a geographic location (between 10:00 a.m. and 11:00 a.m., or 1200 block of Main St.).

The minimum locate schedule (ping frequency of occurrence that GPS data is received from the Vehicle) shall be every one minute for fully automated Collection and every ten seconds for other Collection Vehicles, when within the Service Area.

E. Homeless Encampments

CONTRACTOR acknowledges:

- Homeless Encampments are temporary and homeless individuals are transient, and
- Homeless Encampments are not Customers and therefore Solid Waste generated and discarded in the Right-of-Way is considered Abandoned Waste, and
- Public health and safety requires that Solid Waste generated in Homeless Encampments must be removed not only when individuals abandon a Homeless Encampment, but also when they occupy it.

CONTRACTOR shall not enter a Homeless Encampment or remove anything from a Homeless Encampment except upon Director request. CONTRACTOR shall not remove any Unpermitted Waste, including biological or hazardous waste.

1. Abandoned Homeless Encampments

Within two business days of Director request, CONTRACTOR shall Collect, transport, and Divert or Dispose of, all Solid Waste discarded in a Homeless Encampment that has been abandoned and identified by Director. CONTRACTOR shall Collect Solid Waste, including litter and Abandoned Waste whether it is discarded in containers or on the ground. CONTRACTOR will provide that Contract Service in accordance with COUNTY policy. For example, COUNTY policy may require CONTRACTOR to place Abandoned Waste and other discards in containers and deliver them to a storage facility pending a retrieval by the individual owner. As part of these Contract Services, CONTRACTOR shall provide all equipment such as Container (including such as Carts, Dumpsters and roll-off bins) and Vehicles (including as Refuse Collection and flatbed trucks), and labor.

2. Occupied Homeless Encampments

Upon Director request, CONTRACTOR shall keep the Public Right-of-Way near Homeless Encampments occupied by individuals free of Abandoned Waste.

a. *Container Distribution*

CONTRACTOR shall place Containers (including Carts and Dumpsters), bags, cardboard boxes, and/or Sharps Containers in a safe and accessible location, in CONTRACTOR's judgment. Local homeless support groups may be able to assist in distribution, but that service is not guaranteed. Bags shall be:

- Translucent color to prevent bag from being turned inside-out to hide printing, or a solid color if printing is also on the inside.
- Preprinted with multiple, large font "TRASH" and "BASURA" plus the mirror image (if the bag is turned inside-out)
- Preprint Disposal bilingual procedures on the bag or a separate piece of paper included with the bag
- Approximately 35-gallon capacity with drawstrings or a tie
- At least 3 millimeters in thickness to deter puncture by needles

b. *Quantity*

The number of Containers is not specified. However, to maximize efficient Collections, CONTRACTOR is to inform Director if Containers in an area are frequently less than one-half full or if the number of Containers distributed is significantly higher than the number Collected.

Following consultation with the Director and upon Director consent, CONTRACTOR may change its method of Collection. For example, if cardboard boxes are frequently destroyed or removed from the Set-Out Site, CONTRACTOR may request providing Dumpsters without wheels or bags. As another example, if bags are frequently blown away or used by homeless individuals for storage, CONTRACTOR may request providing Dumpsters.

c. *Collection, Transport, and Diversions/Disposal*

Each week CONTRACTOR shall Collect Solid Waste discarded in Containers (including Carts and Dumpsters), bags and cardboard boxes, following consultation with and approval of Director.

The Set-Out Site is difficult to determine in advance and will need to be determined on case-by-case using CONTRACTOR's judgment. For bags, it may be necessary to Collect from outside each individual shelter or from a central pile. Property owners may not want a pile near them and a pile may attract other Abandoned Waste.

Prior to Collecting a Container, CONTRACTOR shall use Best Efforts to ascertain that no one is sheltered inside the Container.

CONTRACTOR shall transport and Divert or Dispose of, all Solid Waste that it Collects

EXHIBIT 3A3 – Additional Services

If this Exhibit is inconsistent or conflicts with other provisions of this CONTRACT, this Exhibit governs as provided under Part 10 B7.

A. **Mulch and Compost Giveaway Program (Item H7 of Exhibit 3A1)**

CONTRACTOR shall offer at least 40 cubic yards of Mulch and 40 cubic yards of Compost at each event, or any volume requested by Director not to exceed 80 cubic yards of Mulch and 80 cubic yards of Compost per event.

B. **Bulky Item and Excess Solid Waste Collection (Item H3 of Exhibit 3A1)**

CONTRACTOR shall Collect Bulky Items and excess waste discarded at the Set-Out Site on next regularly scheduled Collection day upon at least 24-hours' Notice by the Customer or Occupant or other date agreed to between that Customer or Occupant and CONTRACTOR. CONTRACTOR shall not Collect without Notice but rather shall perform the following:

- Tag items with a Non-Collection Notice describing Notice requirements, and
- Contact Occupant, as provided in item C9 of Section 4.

CONTRACTOR shall Collect up to three times per Contract Year all the services prescribed below. For example, Occupant may place two mattresses and five bags of excess Green Waste out for Collection and it will count as one of the three times.

1. **Bulky Items**

In addition to the Annual Curbside Cleanup Event described in item H2 of this Exhibit 3A1, CONTRACTOR shall Collect from each dwelling unit receiving service, a maximum of ten items per pickup.

2. **Excess Refuse**

CONTRACTOR shall Collect Refuse in bags, up to five bags per pickup.

3. **Excess Green Waste**

CONTRACTOR shall Collect Green Waste in bags or bound bundles less than four feet in length, up to ten bags/bundles per pickup.

Additional On-Call Pickup with Additional cost. In addition to Collection described in item H3 of Exhibit 3A1, at the request of a Customer (not Occupant) more than three times annually for Residential, upon 24-hours' Notice, at charges for additional calls listed on the Attachment 7-3, Task 2 Service Fees of Exhibit 7 and charge for items listed in Contractor Documentation in Exhibit 3D.

C. Annual Curbside Cleanup Events Services (Item H2 of Exhibit 3A1)

For Lennox only:

CONTRACTOR shall conduct the Annual Curbside Cleanup Event each April, unless otherwise instructed Director or requested by CONTRACTOR and approved by Director.

Because Collecting large amounts of Bulky Items, excess Refuse and excess Green Waste with large Collection Vehicles may be unsafe on the narrow, mountain roads in this Service Area, CONTRACTOR shall submit an alternative plan that may include either or both the following methods:

1. Roll-Off Bins

CONTRACTOR shall place bins at locations that will be temporarily available to Occupants for disposal of Bulky Items or Excess Solid Waste. CONTRACTOR shall site locations that are conveniently located and safe to its Occupants and submit a list of these locations for Director's approval.

2. Increased Bulky Item and Excess Solid Waste Collection (Item H3 of Exhibit 3A1 and above in Section B of this Exhibit 3A3)

EXHIBIT 3D – Contractor Documentation

All documentation listed below is to be attached to CONTRACT as Exhibit 3D. Use of Director provided templates is required where applicable.

A. Notice to Director Required

1. CONTRACTOR's Permit and Permit Application

Include all Permits required by County Code (such as a waste collector Permit from COUNTY Department of Public Health) or other Applicable Law.

2. No Longer Used

3. Container Specifications

Include Container capacity options, color, manufacturer's orders and invoices, label content and placement (item D of Exhibit 3A1).

4. Vehicle Specifications

Include vehicle identification number, model, make, year, purchase order (if applicable) and fuel type.

5. Subcontractors

Include Subcontractors' names, the amount of Goods or Services less than \$50,000 that each Subcontractor provides to CONTRACTOR, and a description of CONTRACTOR's relationships to each Subcontractor, including ownership interests; but excluding Director-approved Subcontractors (Part 9M of Exhibit 5).

6. Office Address

See Section 6A and Section 6B1, Contractor Office Hours.

Green Waste Quarantine Zone Agreement with CDFA

B. Director Consent Required

1. Form of Non-Collection Notice (Section 4C)

Include any Green Waste exclusions.

2. Waiver of Liability

Include form of any waiver of liability (Section 4B1) and form of any Indemnification (Part 4 of Exhibit 5)

3. Terms and Conditions Summary (item L1 of Exhibit 3A1)

4. Unpermitted Waste Screening Protocol (Section 13)

5. Acknowledgment

Receipt of fact sheets relating to form of Nonemployee Injury Report (Part 4B6 of Exhibit 5) and Safely Surrendered Baby Law (Part 12B2 of Exhibit 5).

6. Insurance and Performance Assurance (Part 4 of Exhibit 5 and Section 15)

7. Internal Revenue Service Notice 1015 (Part 12B1 of Exhibit 5)

8. CONTRACTOR's EEO Certification (Part 12D3 of Exhibit 5)

9. No longer used

10. Sharps Collection (item H6 of Exhibit 3A1)

11. Mulch and Compost Giveaway Program (item H7 of Exhibit 3A1)

12. No longer used

13. Director-Approved Subcontractors

Include Subcontractors' names, the amount of Goods or Services more than \$50,000 that each Subcontractor provides to CONTRACTOR, and a description of CONTRACTOR's relationships to each Subcontractor, including ownership interests (Part 9M of Exhibit 5).

14. Backup Service Plan (Section 11C)

15. Key Personnel (Section 4J)

With contact information (name, address, Office and mobile phone numbers, e-mail address)

- a. *ALL CONTRACTOR MANAGERS (see definition of "Contractor Manager" in Attachment 5-10A)*
- b. *AUTHORIZED REPRESENTATIVE OF CONTRACTOR (Part 9H of Exhibit 5)*
- c. *SERVICES SAFETY OFFICIAL (Part 12E1 of Exhibit 5)*

16. Route Maps

Route maps are to indicate all starting and ending points.

17. Facilities and Solid Waste Facilities

Designated by CONTRACTOR (item F of Exhibit 3A1), including the following information:

- Name, location, owner, and operator, with telephone contact;
- Types of materials accepted and rejected; and
- If applicable, methodology used by each Processing facility for allocating materials, including Disposed residue, to the Service Area, with sample Reports.
- Reasons for changing the facility designation;

CONTRACTOR may designate a new facility that has higher fees than the prior facility, but it may not pass increased costs to its Customers or the COUNTY by increasing the Service Fee. The Service Fee will not be adjusted to compensate CONTRACTOR if costs at the new facility are greater than those at the prior facility. Item E of Exhibit 7 is not applicable.

18. Additional CONTRACTOR Commitments

Those made in its proposal for procurement of this CONTRACT (item M of Exhibit 3A1).

19. Transition Roll-Out Plan (item K of Exhibit 3A1)

20. Difficult to Service Occupants (Item O of Exhibit 3A1)

CONTRACTOR must explain to Director:

- Why CONTRACTOR proposes changes Service Specifications for an address on Director's difficult-to-service list under Item O of Exhibit 3A1, and
- What changes CONTRACTOR will make for alternative Collection, such as different Collection Vehicle or manual Collection.

21. Movement of Green Waste

CONTRACTOR shall comply with all Applicable Laws regarding transportation of Green Waste, including the California Department of Food and Agriculture's (CDFA's) regulations that quarantine certain types of Green Waste and restrict its movement. See the following website for more information: (<https://www.cdfa.ca.gov/plant/pe/InteriorExclusion/quarantine.html>).

CONTRACTOR shall give Director a copy of either of the following:

- Application to CDFA for the agreement
- The completed CDFA agreement

LENNOX GARBAGE DISPOSAL DISTRICT
 EXHIBIT 3D—CONTRACTOR DOCUMENTATION
 A. NOTICE TO DIRECTOR REQUIRED
 SIGNATURE PAGE 1 of 3

TITLE	TOTAL NO. OF PAGES	CONTRACTOR INITIALS	COUNTY INITIALS
A.1 Contractor's Permit and Permit Application	14	JTW	[Signature]
A.2 Inventory of Service Assets	1	JTW	[Signature]
A.3 Container Specifications	13	JTW	[Signature]
A.4 Vehicle Specifications	18	JTW	[Signature]
A.5 Subcontractors	1	JTW	[Signature]
A.6 Office Address	1	JTW	[Signature]



 DIRECTOR

8/9/18

 DATE



















 CONTRACTOR





9 AUGUST 2018

 DATE

LENNOX GARBAGE DISPOSAL DISTRICT
 EXHIBIT 3D—CONTRACTOR DOCUMENTATION
 B. DIRECTOR CONSENT REQUIRED
 SIGNATURE PAGE 2 of 3

TITLE	TOTAL NO. OF PAGES	CONTRACTOR INITIALS	COUNTY INITIALS
B.1 Form on Non-Collection Notice	2	JHw	
B.2 Waiver of Liability	2	JHw	
B.3 Terms and Conditions Summary	3	JHw	
B.4 Unpermitted Waste Screening Protocol	7	JHw	
B.5 Acknowledgement	4	JHw	
B.6 Insurance and Performance Assurance	25	JHw	
B.7 Internal Revenue Service Notice 1015	2	JHw	
B.8 Contractor's EEO Certification (Form PW-7)	2	JHw	
B.9 Intentionally Omitted	1	JHw	
B.10 Sharps Collection	2	JHw	
B.11 Mulch and Compost Giveaway Program	2	JHw	
B.12 Alternatives to Fully Automated Collection 96-Gallon Carts	2	JHw	
B.13 Director-Approved Subcontractors	1	JHw	
B.14 Backup Service Plan	3	JHw	
B.15 Key Personnel	3	JHw	
B.16 Route Maps	3	JHw	
B.17 Facilities and Solid Waste Facilities	10	JHw	

LENNOX GARBAGE DISPOSAL DISTRICT
EXHIBIT 3D—CONTRACTOR DOCUMENTATION
C. DIRECTOR CONSENT REQUIRED
SIGNATURE PAGE 3 of 3

B.18 Additional Contractor Commitments	2	JHW	
B.19 Transition Roll-Out Plan	3	JHW	
B.20 Difficult to Service Occupants	2	JHW	
B.21 Movement of Green Waste	8	JHW	

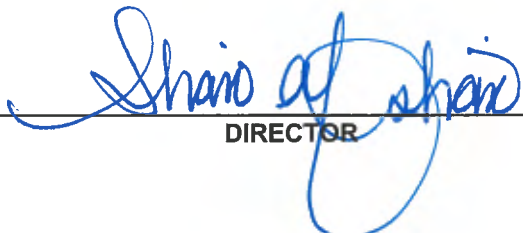

DIRECTOR

8/9/18

DATE



CONTRACTOR

9 AUGUST 2018

DATE

Exhibit 3D-Contractor Documentation



Item A.1 – CONTRACTOR’S PERMIT AND PERMIT APPLICATION

This item consists of 14 pages (including this page).

Item A.1 – CONTRACTOR’S PERMIT AND PERMIT APPLICATION

Enclosed, please find the following Ware Disposal Inc. permits, as required.

- Ware Disposal Inc. County of Los Angeles Waste Collector Permit from the Los Angeles County Department of Health Services. The current Waste Collector Permit is operational for calendar year 2018 (Number PR157340) (see below for waste collector permit);
- Ware Disposal Inc. California Integrated Waste Management Board Covered E-Waste & Recycling permit for calendar year 2018 (CEWID #116831);
- Ware Disposal Inc. California Integrated Waste Management Board Waste Tire Hauler permit for calendar year 2018 (TPID #1600133);
- Ware Disposal Inc. Department of Toxic Substances Control EPA Number as a hazardous waste generator/handler (CAL000347005)
- Ware Disposal Inc. California Department of Food and Agriculture Permit/Compliance Agreement for transporting green waste (30-CITRUS-0021).

 Jeffrey D. Gunzenhauser, MD MPH Interim Health Officer	THIS PERMIT MUST BE CONSPICUOUSLY DISPLAYED ON THE PREMISES
PR Number: PR0157340 Program ID: WARE DISPOSAL INC. Description: SWF - WASTE COLLECTOR YARD FEE	Public Health Permit Valid Until 12/31/2018
Facility Owner - Mail Address WARE DISPOSAL INC. P.O. BOX 131B SANTA ANA, CA 92702	Facility Location WARE DISPOSAL INC. 1451 MANHATTAN AVE FULLERTON, CA 92831
SWA	
	

Ware Disposal Inc.

Lennox GDD



Business Detail: Ware Disposal Company, Inc. (TWIC) (1600133)

New Search

Businesses Info	
Business Name	Ware Disposal Company, Inc. (TWIC)
Business TPID	1600133
Website	
Contact Person(s)	Jay Ware, Jason RMJH, Manny Gonzalez

Mailing/Site Information	
Site Address:	
1451 Manhattan Ave Fullerton, CA 92831-5221 United States County: Orange Phone: (714) 664-0159	
Mail Address:	
P O Box 1318 Santa Ana, CA 92707-1318 United States County: Orange Phone:	

Current Role Status	
ROLE	STATUS
hauler	Registered
Generator	Yes

Waste Tire Permit Summary
No Permit record for this business.



Last updated: Data updated continuously
 Waste Tire Program: <http://www.calrecycle.ca.gov/Tires>
 Hotline: (866) 898-0630 (toll free) WasteTires@calrecycle.ca.gov

[Conditions of Use](#) | [Privacy Policy](#) | [Language Complaint Form](#)
 ©1995-2018 California Department of Resources Recycling and Recovery (CalRecycle). All rights reserved.

STATE OF CALIFORNIA

DEPARTMENT OF RESOURCES RECYCLING AND RECOVERY

REGISTERED

WASTE TIRE HAULER

Ware Disposal Company, Inc. (TWIC)
P.O. Box 1318
Santa Ana, CA 92707-1318

ISSUED BY



DEPUTY DIRECTOR

VEHICLE LICENSE PLATE NUMBER

8D25147

UNIT NUMBER (INTERNAL USE)

DIGITAL SERIAL NUMBER

18-00546

ISSUE DATE

October 25, 2017

EXPIRATION DATE

December 31, 2018

CA RECYCLE TPID NUMBER

1600133

FOR QUESTIONS CONCERNING THIS REGISTRATION, PLEASE CALL (866) 896-0600

ONLY ORIGINAL REGISTRATION VALID

DO NOT COPY OR REPRODUCE

Ware Disposal Inc.

Lennox GDD

Organization Details

<http://www.cafrecycle.ca.gov/Electronics/Reports/Detail.aspx?Partici>



Organization Details: Ware Disposal, Inc. (CEWID: 116831)

New Search

Current Status: Active
Approved As: Collector
Application Last Approved: 9/5/2017
Renewal Application Due: 6/7/2019
Contact: Jay Ware (jay@waredisposal.com)
Phone: (714) 664-0077
Signatories:
 Jason Rush
 Jay Ware
Physical Address:
 1451 Manhattan Avenue
 Fullerton, CA 92831
Mailing Address:
 P.O. Box 1318
 Santa Ana, CA 92702 1318

Collector Status	Started	Ended
Active	9/5/2017	
Active - Applicant is or was approved to operate in the specified row for the date range ->Close		

Disclaimer: The California Department of Resources Recycling and Recovery (CalRecycle) is dedicated to providing timely and accurate information so waste can be managed in accordance with all applicable laws and policies. Due to the rapidly evolving nature of laws and policies pertaining to the management of electronic product discards, CalRecycle cannot guarantee that organizations listed as resources herein are in full compliance with applicable rules. CalRecycle conducts ongoing efforts to determine the scope of these organizations' services. However, these may change without CalRecycle's knowledge. The inclusion or exclusion of an organization from these lists does not constitute an endorsement of that organization's regulatory status or environmental performance. For additional information about the management of discarded electronic products, please refer to material handling (15627), administered by the Department of Toxic Substances Control.

Last Updated: Data updated continuously
 Electronic Discards Help: www.cafrecycle.ca.gov/ehelp/
 email: info@cafrecycle.ca.gov | 916-341-6269

[Home](#) | [About Us](#) | [Privacy Policy](#) | [Language](#) | [Contact Form](#)
 ©1999 - 2018 California Department of Resources Recycling and Recovery (CalRecycle). All rights reserved.



Matthew Rodriguez
Secretary for
Environmental Protection

**Department of Toxic
Substances Control**

Barbara A. Lee, Director
1001 I Street
P.O. Box 806
Sacramento, CA 958120806



Edmund G. Brown Jr.
Governor

EPA ID PROFILE

Map
ID Number: CAL000347005 Status: ACTIVE
Name: WARE DISPOSAL INC Inactive Date:
County: ORANGE Record Entered: 10/7/2009 2:52:25 PM
NAICS: 56292 Last Updated: 7/10/2017 9:50:28 AM

	Name	Address	City	State	Zip Code	Phone
Location	WARE DISPOSAL INC	1451 MANHATTAN AVE	FULLERTON	CA	928315221	
Mailing		PO BOX 1318	SANTA ANA	CA	927021318	
Owner	BJW PROPERTIES LLC	1451 MANHATTAN AVE	FULLERTON	CA	928315221	7146640677
Operator/Contact	JAY WARE	1451 MANHATTAN AVE	FULLERTON	CA	92831	7146640677

Based Only Upon ID Number: CAL000347005

Calif. Manifests?	Non Calif. Manifests?	Transporter Registration?
Yes	N/A	ACTIVE

California and Non California Manifest Tonnage Total and Waste Code by Year Matrix by Entity Type (if available) are on the next page

Calif. Manifest Counts and Total Tonnage

Top line represents Manifest Count and Bottom line represents Total Tonnage

Ware Disposal Inc.

Lennox GDD

Year	Generator	Trans. 1	Trans. 2	TSDf	ALT. TSDf
2011	2 0.15000	0 0.00000	0 0.00000	0 0.00000	0 0.00000
2012	1 1.66800	0 0.00000	0 0.00000	0 0.00000	0 0.00000
2013	5 4.08400	0 0.00000	0 0.00000	0 0.00000	0 0.00000
2014	2 3.45800	0 0.00000	0 0.00000	0 0.00000	0 0.00000

Non California Manifest Total Tonnage

No Records
Found

Waste Code Matrix					
California	Generator	Trans. 1	Trans. 2	TSDf	Alt. TSDf
RCRA	Generator	Trans. 1	Trans. 2	TSDf	Alt. TSDf

[Waste Code Matrix as a spreadsheet](#)

The Department of Toxic Substances Control (DTSC) takes every precaution to ensure the accuracy of data in the Hazardous Waste Tracking System (HWTS). However, because of the large number of manifests handled, inaccuracies in the submitted data, limitations of the manifest system and the technical limitations of the database, DTSC cannot guarantee that the data accurately reflect what was actually transported or produced.



Department of Toxic Substances Control

Maziar Movassaghi, Acting Director
1201 T Street
P.O. Box 806
Sacramento, California 95812 0806



Arif Ali, Chief of Compliance

ATTN: JAY WARE
WARE DISPOSAL INC
P.O. BOX 8089
NEWPORT BEACH, CA 92658

EPA ID Number Issued: October 07, 2009
Location Address:
1451 MANHATTAN AVE
FULLERTON CA 9283152

PERMANENT RECORD - DO NOT DESTROY
YOUR CALIFORNIA EPA IDENTIFICATION NUMBER IS:

CAL000347005

This is to acknowledge that a permanent California Environmental Protection Agency identification (EPA ID) Number has been assigned to your place of business.

An EPA ID Number is assigned to a person or business at a specific site. It is only valid for the location and person or business to which it was assigned. If your business has multiple generation sites, each site must have its own unique number. If you stop handling hazardous waste, move your business, change ownership, change mailing address, or change the type or amount of waste you handle, you must notify the Department of Toxic Substances Control immediately. If your business has moved, your EPA ID Number must be canceled. A new number must be obtained for your new location if you continue to generate hazardous waste.

This EPA ID Number must be used for all manifesting, record keeping, and reporting requirements. Please retain this notice in your files.

Department of Toxic Substances Control
Hazardous Waste Management Program
Generator Information Services Section
Telephone: (916) 255-1136 or California Only Toll-free Number (800) 618-6842

Operator's Initials: jhodes

version: July 2006

Printed on Recycled Paper

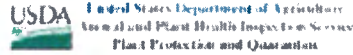

**COOPERATIVE ASIAN CITRUS PSYLLID AND HUANGLONGBING QUARANTINE PROGRAM
COMPLIANCE AGREEMENT**

Orange County Agricultural Commissioner / CDFA / USDA

(Pursuant to California Food and Agriculture Codes 5701-5705, California Code of Regulations 3435, 3439, and 3154, and the Federal Domestic Quarantine Order, Citrus Greening Disease and Asian Citrus Psyllid, and Master Permits QC1386, QC1464, and QC1480)

Orange County Agricultural Commissioner's Office
 Street Address: 222 E Bristol Lane
Orange, CA 92865
 Phone: (714) 955-0100
 Fax: (714) 921-2713
 Contact: Rebekah Ban

Compliance Agreement Number 30-C HTRUS-0021

Establishment Name:	WARE DISPOSAL INC			
Owner / Manager Name:	JAY WARE			
Mailing Address:	PO BOX 1318	City:	SANTA ANA	Zip: 92702 1318
Physical Address:	1451 MANHATTAN AVENUE	City:	FULLERTON	Zip: 92831 5221
Phone:	(714) 864-0677	E-Mail:	jason@waredisposal.com	
Cross Street:	Manhattan and Burton, Fullerton	Lat/Long:	33 558 19, -117 902839	

Program:
 The Orange County Agricultural Commissioner, the California Department of Food and Agriculture (CDFA), and the United States Department of Agriculture (USDA), cooperating as the Asian Citrus Psyllid and Huanglongbing Disease Quarantine Program

Business/Establishment:
 Establishment Name (subsequently referred to as "Establishment"):

WARE DISPOSAL INC

Background:
 The pests known as Asian citrus psyllid (ACP) and Huanglongbing (HLB) present a real and ongoing threat to the agricultural industry, environment and economy of the State of California. Movement of regulated articles and commodities is a recognized channel for the spread of ACP and HLB from established areas to new locations. The ACP and HLB Quarantine Program is a cooperative effort between public entities that are responsible for mitigating the movement of ACP from regulated areas where the pest is established to new locations. The list of regulated articles and commodities can be found here <http://phpps.cdffa.ca.gov/PE/Interim/Exclusions/wdf/acpsyllid.pdf>

AGREEMENT:

A. The Asian Citrus Psyllid and Huanglongbing Quarantine Program, hereafter referred to as the Program, will permit your establishment to self-execute the Asian Citrus Psyllid and Huanglongbing quarantine requirements attached as exhibits checked below, inclusive and incorporated into this agreement by reference as if fully set out. The exhibits checked below are binding:

Check all that apply.

<input type="checkbox"/>	Exhibit ACP Citrus-G	Grower / Grove Manager
<input type="checkbox"/>	Exhibit ACP Citrus-PH	Citrus Packer / Citrus Juicer/ Citrus Processor
<input checked="" type="checkbox"/>	Exhibit ACP Citrus-T	Transporter / Hauler - Citrus Fruit
<input type="checkbox"/>	Exhibit 1386-G	Grower / Grove Manager - Mandarins with Stems and Leaves
<input type="checkbox"/>	Exhibit 1386-PH	Packer / Processor - Mandarins with Stems and Leaves
<input checked="" type="checkbox"/>	Exhibit 1386-T	Transporter / Hauler - Mandarins with Stems and Leaves
<input type="checkbox"/>	Exhibit 1480-G	Grower / Grove Manager in an HLB Quarantine Area
<input type="checkbox"/>	Exhibit 1480-PH	Packer / Processor - Citrus Fruit Grown in an HLB Quarantine Area
<input type="checkbox"/>	Exhibit X1	Program Management Practices for Aerial Spray Treatments
<input type="checkbox"/>	Exhibit X2	Program Management Practices for Ground Spray and Drunch Treatments
<input type="checkbox"/>	Exhibit X3	Program Management Practices for Hazardous Materials Spills

B. In exchange for the Program's promise contained in sub-paragraph "A" above, the Establishment agrees to abide by the following rules and regulations:

1. Handle, process, and/or move regulated articles in accordance with the Asian Citrus Psyllid and Huanglongbing quarantine requirements;
2. Follow the Program's instructions regarding the use of all permits and certificates;
3. Maintain and make such records, as the Program requires, accessible for inspection upon reasonable notice by the Program Officer. These records shall be maintained for a period of the later of 2 years or the resolution of any outstanding claims.

C. This agreement becomes effective on signing and shall remain in effect until canceled by either party on 30 days notice to the other at the address of either appearing above. However, the Program may accelerate the notice to immediate for cause, including but not limited to the Establishment's abandonment of the procedures outlined in the attached Exhibit(s).

D. Establishment assumes liability, if any, arising from the manner in which Establishment sells, handles or distributes any regulated host material.

NOTICE: Any signatory or employee of any signatory who violates the terms of this Compliance Agreement may be subject to civil penalties pursuant to California Food and Agricultural Code Section 5705

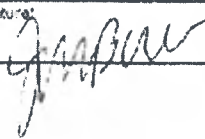
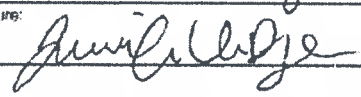
Signed in the County of <u>Orange</u> in the State of California on <u>02</u> / <u>27</u> / <u>2018</u>	
Establishment Manager/Owner	Program Officer
Print Name: JAY WARE	Print Name: <i>Jennifer VanDyke</i>
Signature: 	Signature: 



Compliance Agreement # 30-CITRUS-021

**EXHIBIT: ACP CITRUS – T
TRANSPORTER / HAULER**

**PROVISIONS FOR THE INTRASTATE MOVEMENT OF BULK CITRUS FRUIT
FROM OR WITHIN AN ASIAN CITRUS PSYLLID BULK CITRUS REGIONAL QUARANTINE ZONE**

To Be Used in Conjunction with QC Permit 1464

Establishment agrees to the following:

1. Establishments Under Compliance

- a. Only transport shipments from a Grower/Grove Manager operating under compliance with the ACP Program.
- b. Only transport shipments to a Packer/Juicer/Other Processor operating under compliance with the Program.

*Establishments operating under compliance can be verified online at:
https://www.cdfa.ca.gov/plant/acc/req_establishments.html*

2. Safeguarding

All shipments of citrus fruit shall be safeguarded the entire time while in transit, beginning before the vehicle departs the loading site and until it reaches final destination for offloading. Any screen mesh used as an ACP-proof barrier shall be 0.3 square millimeters (e.g. 0.547 x 0.547, or 0.5 x 0.6) or less in size. Approved safeguarding measures include the following:

- a. Citrus fruit is transported in a fully enclosed vehicle, or
- b. Transporting vehicles which have solid wall construction on sides and rear; a solid tarpaulin or ACP-proof barrier shall cover the top. The tarp or ACP-proof barriers shall be in good repair without tears or holes and be securely fastened to the solid walls of the truck, ensuring no gaps are present and in a manner that would prevent exposure to ACP or the loss of fruit, leaves, stems, branches, and plant debris while in transit, or
- c. Transporting vehicles constructed of wire mesh or expanded metal shall be completely covered with a solid tarp or ACP-proof barriers that extend down to the truck bed, ensuring no gaps are present. The tarp or ACP-proof barrier shall be in good repair without tears or holes and be securely fastened to the bed of the truck in a manner that would prevent exposure to ACP or the loss of fruit, leaves, stems, branches, and plant debris while in transit, or
- d. Transporting vehicles which have a flatbed trailer with field pallets or bins shall be entirely covered to the bed of the truck with a solid tarp or ACP-proof barrier. The tarp or screen mesh shall be in good repair without tears or holes and be securely fastened to the bed of the truck, ensuring no gaps are present around the bins, and in a manner that would prevent exposure to ACP or the loss of fruit, leaves, stems, branches, and plant debris while in transit, or
- e. Any other Program approved manner specified in the "Special Instructions."

3. Transporter Cleanliness

The vehicle and/or trailer used for transporting the shipment must be free of all leaf and stem debris and free of all life stages of ACP prior to transport and after delivery.

4. Evidence of Compliance

Place a copy of the compliance agreement, this exhibit, and the applicable "ACP-Free Declaration" form in each transport vehicle.

5. Direct Route

Take the most continuous, direct route, without interruption to a Program approved receiver.

6. Green Waste Disposal

All green waste, including leaf and stem debris, must be continuously collected, safeguarded, and disposed of in accordance with the Program, local County Agricultural Commissioner, under QC Master Permit 1289 or other Program approved manner.

12/27/2017

Page 1 of 2

- 7. **Records**
Maintain records of all ACP host shipments for a minimum of two years and make such records available to Program officials immediately upon request.
- 8. **Training**
Ensure all employees receive training to be compliant with all specifications of the compliance agreement and this exhibit.
- 9. **Spill Notification**
Notify the Program as soon as possible and no later than 24 hours after spillage of any shipment.
- 10. **Vehicle Tracking System**
List all truck and trailer license plates below. The Establishment shall update the Program immediately any time license plates are added, changed, or are no longer in use. If more space is needed, continue on back of this exhibit or attach pages as needed.
- 11. **Violation**
Violation of any terms of the compliance agreement or this exhibit shall result in the suspension of the compliance agreement until an investigation is completed and for a minimum period of two weeks.

Transporter License Plates Will be provided once vehicles have been procured.

1		11	
2		12	
3		13	
4		14	
5		15	
6		16	
7		17	
8		18	
9		19	
10		20	

SPECIAL INSTRUCTIONS:

JAY WARE, Ware Disposal Inc.
Printed name (Owner/Manager)

Signature of Establishment

27 February 2018
Date

Failure to comply with any stipulation outlined above may result in civil penalties pursuant to California Food and Agricultural Code Section 5705 and/or revocation of this Agreement.

12/27/2017

Page 2 of 2



Compliance Agreement # 30-CITRUS-0021

**EXHIBIT 1386-T
TRANSPORTER/HAULER
OF MANDARINS WITH STEMS AND LEAVES**

**PROVISIONS FOR THE INTRASTATE MOVEMENT OF MANDARINS WITH ATTACHED STEMS AND/OR LEAVES
FROM OR WITHIN AN ASIAN CITRUS PSYLLID BULK CITRUS REGIONAL QUARANTINE ZONE**

To Be Used in Conjunction with Master Permit QC 1386

Establishment agrees to the following:

1. Establishments Under Compliance

- a. Ensure that mandarin fruit with attached stems and leaves being transported is produced by a grower/grove manager under compliance with the ACP Program.
 - i. Mandarins with stems and leaves must not originate or be processed in an area quarantined for Huanglongbing (HLB) or regulated for sweet orange scab (SOS); and
 - ii. The fruit must not be commingled with fruit that has been in an area quarantined for HLB or regulated for SOS.
- b. Ensure fruit is delivered to and handled by packers/processors under compliance with the Program. Establishments operating under compliance can be verified online at https://www.cdfa.ca.gov/plant/acc/req_establishments.html

2. Safeguarding

All shipments of mandarin fruit with attached stems and leaves must be safeguarded the entire time while in transit, beginning before the vehicle departs the loading site and until it reaches final destination for offloading. Any screen mesh used as an ACP-proof barrier shall be 0.3 square millimeters (e.g. 0.547 x 0.547, or 0.5 x 0.6) or less in size. Approved safeguarding measures include the following:

- a. Mandarin fruit is transported in a fully enclosed vehicle, or
- b. Transporting vehicles which have solid wall construction on sides and rear, a solid tarpaulin or ACP-proof barrier shall cover the top. The tarp or ACP-proof barriers shall be in good repair without tears or holes and be securely fastened to the solid walls of the truck, ensuring no gaps are present and in a manner that would prevent exposure to ACP or the loss of fruit, leaves, stems, branches, and plant debris while in transit, or
- c. Transporting vehicles constructed of wire mesh or expanded metal shall be completely covered with a solid tarp or ACP-proof barriers that extend down to the truck bed, ensuring no gaps are present. The tarp or ACP-proof barrier shall be in good repair without tears or holes and be securely fastened to the bed of the truck in a manner that would prevent exposure to ACP or the loss of fruit, leaves, stems, branches, and plant debris while in transit, or
- d. Transporting vehicles which have a flatbed trailer with field pallets or bins shall be entirely covered to the bed of the truck with a solid tarp or ACP-proof barrier. The tarp or screen mesh shall be in good repair without tears or holes and be securely fastened to the bed of the truck, ensuring no gaps are present around the bins, and in a manner that would prevent exposure to ACP or the loss of fruit, leaves, stems, branches, and plant debris while in transit, or
- e. Any other Program approved manner specified in the "Special Instructions"

3. Transporter Cleanliness

The vehicle and/or trailer used for transporting the shipment must be free of all leaf and stem debris and free of all life stages of ACP prior to transport and after delivery.

4. Evidence of Compliance

Place a copy of the compliance agreement, this exhibit, and the applicable "ACP-Free Declaration" form in each transport vehicle



5. **Direct Route**
Take the most continuous, direct route, without interruption to a Program approved receiver
6. **Green Waste Disposal**
All green waste, including leaf and stem debris, shall be continuously collected, safeguarded and disposed of in accordance with the Program, local County Agricultural Commissioner, under QC Master Permit 1289 or other Program approved manner
7. **Records**
Maintain records of all ACP host shipments for a minimum of two years and make such records available to Program officials immediately upon request.
8. **Training**
Ensure all employees receive training to be compliant with all specifications of the compliance agreement and this exhibit.
9. **Spill Notification**
Notify the Program as soon as possible and no later than 24 hours after spillage of any shipment.
10. **Vehicle Tracking System**
List all truck and trailer license plates below. Update the Program immediately any time license plates are added, changed, or are no longer in use. If more space is needed, continue on the back of this exhibit or attach pages as necessary.
11. **Violation**
Violation of any terms of the compliance agreement or this exhibit shall result in the suspension of the compliance agreement until an investigation is completed and for a minimum period of two weeks.

Transporter License Plates Will be provided once vehicles have been procured

1		8	
2		9	
3		10	
4		11	
5		12	
6		13	
7		14	

SPECIAL INSTRUCTIONS: _____

JAY WARE Ware Disposal Inc
Printed name (Owner/Manager)

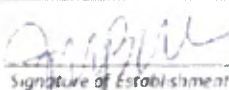
Signature of Establishment

27 February 2018
Date

Failure to comply with any stipulation outlined above may result in civil penalties pursuant to California Food and Agricultural Code Section 5705 and/or revocation of this Agreement.

12/27/2017

Page 2 of 2

Exhibit 3D-Contractor Documentation

Item A.2 – INVENTORY OF SERVICE ASSETS

This item consists of 1 pages (including this page).

No Longer Used.

Exhibit 3D-Contractor Documentation

Item A.3 – CONTAINER SPECIFICATIONS

This item consists of 13 pages (including this page).

BILL OF SALE
(Sale of Containers)

This **BILL OF SALE** ("*Agreement*") is made and entered into between Consolidated Disposal Service, L.L.C., a Delaware limited liability company dba Republic Services of Southern California ("*Republic*") and Ware Disposal, Inc., a California corporation ("*Ware*"). The parties shall be collectively referred to herein as the "*Parties*" and individually as a "*Party*," unless specifically identified otherwise. This Agreement shall be effective upon the date that all Parties have executed this Agreement (the "*Effective Date*"), as evidenced by the signatures below.

In consideration of the mutual promises herein made, and for good and valuable consideration, the receipt and adequacy of which is hereby acknowledged, the Parties hereto agree as follows:

1. IDENTIFICATION AND SALE OF CONTAINERS. Ware shall acquire from Republic Three Hundred and Thirty-Eight (338) commercial containers and Four Thousand Seven Hundred and Thirty-Six (4,736) residential containers. Republic agrees to sell to Ware, and Ware agrees to purchase from Republic, said containers (the "*Containers*") as provided in Section 2.

2. PURCHASE PRICE. The Parties agree that Ware will pay Republic a Purchase Price of One Hundred Twenty Thousand Seven Hundred and Eighty-Five Dollars (\$120,785.00) plus sales tax in the amount of Eleven Thousand Four Hundred and Seventy-Five Dollars (\$11,475.00) for a total payment of One Hundred Thirty-Two Thousand Two Hundred and Sixty Dollars (\$132,260.00) (the "*Purchase Price*"). The Parties further agree that the Purchase Price shall be paid on or before August 12, 2018. As of the Effective Date, Republic shall convey and transfer all its rights, title and interest in the containers purchased hereunder to Ware free and clear of all security interests, pledges, mortgages, liens, charges, judgments, adverse claims or any other similar encumbrances ("*Encumbrances*"). Republic shall make the containers available for use no later than the Effective Date unless the Parties agree otherwise in writing.

3. TAXES. Any sales tax associated with the transfer of the Containers pursuant to this Agreement shall be paid to Republic by Ware in the amount described in Paragraph 2. Republic shall remit all sales tax to the relevant taxing authority as applicable. Subject to the foregoing, Ware shall be solely responsible for and pay its own income and other taxes (whether federal, state or local), if any, in connection with the transaction contemplated by this Agreement.

4. REPRESENTATIONS AND WARRANTIES. With respect to the Containers, Ware represents and warrants to Republic that Ware is fully aware of the nature, condition, and location of the Containers. Ware has further conducted to its own satisfaction an independent investigation of the Containers and is not relying upon any representations made to Ware by Republic or any of Republic's agents or employees, except those expressly set forth in this Agreement. Republic

represents and warrants to Ware that Republic has good and marketable title to the Containers, free and clear of any Encumbrances.

5. REMOVAL OF IDENTIFICATION. On or before sixty (60) days after the Effective Date, Ware shall remove or otherwise obscure from the Containers, all visible names, logos or other marks identifying Republic.

6. DISCLAIMER OF WARRANTIES. ALL OF THE CONTAINERS ARE SOLD "AS-IS", "WHERE IS", "WITH ALL FAULTS", AND WITHOUT WARRANTY OR REPRESENTATION EITHER EXPRESS OR IMPLIED AS TO (A) THE VALUE OF THE CONTAINERS, (B) MERCHANTABILITY OR FITNESS FOR ANY PARTICULAR PURPOSE, (C) THE RIGHT TO THE QUIET ENJOYMENT OF THE CONTAINERS, (D) THE DESIGN, CONDITION, OR QUALITY OF MATERIAL OR WORKMANSHIP IN THE CONTAINERS, (E) THE PRESENCE OR ABSENCE OF ANY HAZARDOUS SUBSTANCES IN, UNDER, OR ON, OR DISPOSED OF, OR DISCHARGED FROM THE CONTAINERS; (F) NON-INFRINGEMENT OF INTELLECTUAL PROPERTY RIGHTS; OR (G) ANY OTHER MATTER WHATSOEVER, IT BEING AGREED THAT ALL SUCH RISKS ARE BORNE BY THE PARTY ACQUIRING THE CONTAINERS.

7. ENTIRE AGREEMENT; AMENDMENT. This Agreement constitutes the entire agreement among the Parties concerning the Containers and supersedes all previous correspondence, communications, agreements and understandings, whether oral or written among the Parties with respect to the transaction memorialized by this Bill of Sale. This Agreement may not be modified, in whole or in part, except upon unanimous approval of the Parties and by a writing signed by all the Parties.

8. LEGAL FEES. In the event any legal action is taken by either Party against the other Party to enforce any of the terms and conditions of this Agreement, it is agreed that the unsuccessful Party to such action shall pay to the prevailing Party therein all court costs, reasonable attorneys' fees and expenses incurred by the prevailing Party.

9. HEADINGS. The Headings used in this Agreement are inserted only as a matter of convenience and for reference only and in no way define, limit, or describe the scope of this Agreement or the intent of any provision thereof.

10. GOVERNING LAW. This Agreement, and any amendments or supplements thereto, shall be governed by and construed in accordance with the laws of the State of California without reference to its choice or conflict of laws principles.

11. COUNTERPARTS. This Agreement may be executed in two or more counterparts, each of which shall be deemed an original, but all of which together shall constitute one and the same instrument.

IN WITNESS WHEREOF, the Parties enter into this Agreement. Each person signing this Agreement represents and warrants that he or she has been duly authorized to enter into this Agreement by the Party on whose behalf it is indicated that the person is signing.

**CONSOLIDATED DISPOSAL
SERVICE, L.L.C.**

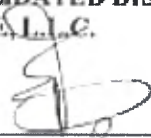
By: 
Name: KAY GARNEAU
Title: General Manager
Date: 7/17/2018

WARE DISPOSAL, INC.

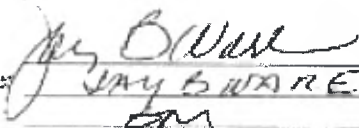
By: 
Name: JAY SWARE
Title: GM
Date: 7/16/2018

Environmental



Rehrig Pacific Roll-out Carts

Proven to withstand the rigors of today's collection systems, Rehrig Pacific's **HuskyLite Roll-out Carts** are setting new industry standards for durability and efficiency. Available in 18 gallon through 95 gallon models, for nearly any curbside application, these carts roll easily even with heavy loads. The continuous one-piece handle provides a strong gripping area and the wide wheelbase makes maneuvering easy.

HuskyLite carts are flexible, yet hold their shape even after years of service. A reinforced top lip adds strength and rigidity as do the double drag rail and reinforced bottom. The specially designed wide ground-hugging base helps keep these carts upright and stable.

Options for the Roll-out Carts include internal and external locking lids, which can be made with slots for collecting confidential documents or cutouts for recyclable beverage containers. Wheel options include blow-molded wheels or quiet treaded snap-on wheels that install in seconds.

Roll-out Carts are shipped with lids already attached, saving additional assembly time.





RELY ON REHRIG

95 Gallon Nestable Bar Roll Out Cart



Specifications	IN/LB	CM/KG
Capacity (Gallons / Liters)	95 Gal	360 L
Overall Depth (D)	33.7	85.7
Overall Width (W)	28.7	72.9
Overall Height with Lid (H)	45.1	114.6
53' Trailer Quantity	486	

Decoration Areas	WIDTH (IN)	HEIGHT (IN)
Side Brand - Hot Stamp (B1)	11.5	7.5
Barcode & Serial Number (B2)	9.75	1.5
Lid Brand - Hot Stamp (B3)	11.0	2.25
4 Color In Mold Label or Hot Stamp (B4)	12.0	8.0

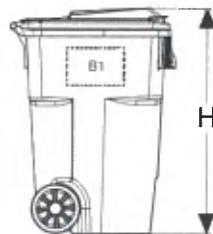

Features & Benefits

- Proven to withstand the rigors of today's household refuse, recyclables and organics collection programs, Backed by 10 year non-prorated warranty
- Meets/Exceeds all ANSI type B & G container standards, Compatible with all ANSI certified Fully and Semi-Automated Lift Arm Lifters
- Constructed of high quality, resilient UV-Stabilized HDPE; Ability to include Post-Consumer Recycled (PCR) material to support your sustainability goals, Available in a wide range of colors
- Continuous one-piece handle provides strong gripping area designed to provide optimum control of a fully loaded cart while the wide wheelbase is designed for easy maneuvering
- Lid is of one-piece construction with a lid handle throughout the front of the lid
- Carts are shipped with lids already attached reducing assembly time
- One piece blow-molded wheels snap on (BMSO) with integrated spacers, taking seconds to assemble
- Permanently imprint cart bodies and/or lids with customized Hot Stamp Branding of Logos and Recycling Slogans, Multi-Colored In Mold Labels (IML's) are also available
- Barcode & Serial Number imprinted to facilitate A&D distribution and manual inventory control and work order tracking
- RFID Tag Enabled option provides innovative asset and participation tracking programs powered by Rvision
- Many additional services and technology offerings available and powered by Rvision to improve capital utilization, enhance customer experience and prevent capital and revenue losses
- Additional Cart Options: Internal and external locking lids, lid cut outs or vents, locking options, and lid stops

Corporate Headquarters
4010 East 26th St., Los Angeles, CA 90058
(800) 421-6244 • (323) 262-5145

Locations
Los Angeles, CA • Orlando, FL • Atlanta, GA • De Soto, KS
Erie, PA • Dallas, TX • Kenosha, WI • Quebec, Canada
Querétaro, Qro Mexico

Web: www.rehrigpacific.com



A FAMILY TRADITION OF GROWTH, SERVICE AND INNOVATION

95GallonNestableBarROC-REV NC
© 2017 Rehrig Pacific Company

Cart Labels:

LENNOX GDD					
TRASH				BASURA	
NOT ACCEPTABLE			NO SE ACEPTAN		
<ul style="list-style-type: none"> ✓ Concrete ✓ Dirt ✓ Large Appliances ✓ Yard Waste 	<ul style="list-style-type: none"> ✓ Construction Debris ✓ Furniture ✓ Recyclables ✓ Hazardous Waste 	<ul style="list-style-type: none"> ✓ Concreto ✓ Tierra y Piedras ✓ Artefactos Eléctricos Voluminosos ✓ Desechos de Palo y Jardines 	<ul style="list-style-type: none"> ✓ Residuos De Construcción ✓ Muebles ✓ Reciclables Desechos Peligrosas 		
<p>THE FOLLOWING HOUSEHOLD HAZARDOUS WASTE MATERIALS ARE NOT ACCEPTABLE (antifreeze, household cleaners, motor oil, paint thinner, paints latex or oil based.</p>			<p>DESECHOS PELIGROSOS DOMÉSTICOS INCLUYE TODO LO CLASIFICADO COMO TOXICO, FLAMABLE O IRRITANTE (anticongelantes, líquidos par limpieza domestica, aceite de automóviles, diluyente de pintura, pinturas, látex y base de aceite</p>		
<p>FOR MORE INFORMATION ABOUT HOW TO DISPOSE OF HOUSEHOLD HAZARDOUS WASTE MATERIAL CALL - 1-800-993-5844</p>			<p>PARA MAS INFORMACIÓN DE DESECHOS DOMÉSTICOS PELIGROSOS POR FAVOR LLAME A 1-800-993-5844</p>		
<p>To request replacement and/or additional container(s) – Contact Ware Disposal Co Inc – 877-714-WARE (9273) County Of Los Angeles Department Of Public Works Monday – Thursday 7:00a.m. to 5:30 p.m. 1-800-993-5844</p>			<p>Para reemplazar y/o pedir bota(s) adicionales llama a Ware Disposal Co Inc. – 877-714-WARE (9273) Condado de Los Ángeles Departamento de Trabajos Públicos Lunes – Jueves 7:00a.m. a 5:30 p.m. – 1-800-993-5844</p>		

LENNOX GDD			
GREEN WASTE			
GREEN WASTE		DESECHOS VERDES	
ACCEPTABLE	NOT ACCEPTABLE	SE ACCEPTAN	NO SE ACCEPTAN
<ul style="list-style-type: none"> ✓ Grass Clippings ✓ Leaves ✓ Brush ✓ Shrubbery Pruning ✓ Sawdust ✓ Tree Trimmings ✓ Tree Limbs 4 Diameter Maximum 	<ul style="list-style-type: none"> ✓ Palm Tree Trimming ✓ Palm Founds ✓ Cactus ✓ Dirt And Rocks ✓ Plastic Or Paper Bags ✓ Animal Waste ✓ Food Waste ✓ Trash 	<ul style="list-style-type: none"> ✓ Recortes De Césped ✓ Hojas ✓ Matorrales ✓ Recortes De Arbustos ✓ Ramas Pequeñas ✓ Aserrín ✓ Recortes De Arboles ✓ Ramas De Arboles, Máximo De 4 Pulgadas De Diámetro 	<ul style="list-style-type: none"> ✓ Recortes De Plañera ✓ Hojas De Palmas ✓ Cacaos ✓ Tierra Y Rocas ✓ Bolas De Plástico o De Papel ✓ Estiércol De Animal ✓ Sobras De Comida
<p>(1) Place all GREEN WASTE in the GREEN containers.</p> <p>(2) Place container on the curb with the lid closed.</p> <p>(3) Bags or boxes will NOT be picked up from the curb.</p>		<p>(1) Ponga todos los DESECHOS VERDES en el recipiente VERDE.</p> <p>(2) Ponga los recipientes en la banqueta con las tapas cerradas.</p> <p>(3) Desechos verdes puestos en la banqueta dentro cajas o bolas as NO serán recogido.</p>	
<p>To request replacement and/or additional container(s) – Contact Ware Disposal Co Inc – 877-714-WARE (9273).</p> <p>County Of Los Angeles Department Of Public Works Monday – Thursday 7:00a.m. to 5:30 p.m. 1-800-993-5844</p>		<p>Para reemplazar y/o pedir bota(s) adicionales llama a Ware Disposal Co Inc – 877-714-WARE (9273)</p> <p>Condado de Los Ángeles Departamento de Trabajos Públicos Lunes – Jueves 7:00a.m. hasta 5:30 p.m. 1-800-993-5844</p>	

LENNOX GDD			
RECYCLABLES			
ACCEPTABLE	NOT ACCEPTABLE	SE ACCEPTAN	NO SE ACCEPTAN
<ul style="list-style-type: none"> ✓ Aluminum & Tin Cans ✓ Aluminum Foil ✓ All Glass Bottles & Jars ✓ Clear, Colored & White Plastic Containers ✓ Newspapers ✓ Mixed Paper ✓ Junk Mail ✓ White Ledger Paper ✓ Corrugated Cardboard ✓ Magazines ✓ Cereal Boxes (With Liners Removed ✓ Telephone Books ✓ Plastic Bags ✓ Plastic Milk Containers ✓ All Plastics Labeled 1 & 2 	<ul style="list-style-type: none"> ✓ Scrap Metal ✓ Window Or Safety Glass ✓ Mirrors ✓ Light Bulbs ✓ Styrofoam ✓ Wax Paper ✓ Ceramics ✓ Clothing ✓ Drinking Glasses ✓ Plastic Wrap ✓ Food Waste ✓ Disposable Diapers 	<ul style="list-style-type: none"> ✓ Botes De Aluminio Y Lata ✓ Papel Aluminio ✓ Todas Las Botella Y Frascos De Vidrio ✓ Los Recipientes De Plástico De Color Charros, De Colores Y Blancos ✓ Periódicos ✓ Todo Tipo De Papel ✓ Correo De Propagandas ✓ Revistas ✓ Papel Blanco ✓ Cartón Corrugado ✓ Cajas De Cereal (Sin Los Forros) ✓ Directorios Telefónicas ✓ Bolsas De Plástico ✓ Botellas De Leche ✓ Todas Los Plásticos Clasificados 1 Y 2 	<ul style="list-style-type: none"> ✓ Desechos De Metal ✓ Vidrio De Ventana O Seguridad ✓ Espejos ✓ Focos ✓ Plástico Esponjoso ✓ Papel Encerado ✓ Ropa ✓ Cerámica ✓ Vasos De Beber ✓ Envoltura Plástico ✓ Sobras De Comida ✓ Pañales Para Tirar
<p>(1) Place all RECYCALBLES in the BLUE container.</p> <p>(2) Place the container on the curb with the lid closed.</p> <p>(3) Bags or boxes will NOT be picked up from the curb.</p>		<p>(1) Ponga todo MATERIAL RECICLABLE en el recipiente AZUL.</p> <p>(2) Ponga los recipientes en la banqueta con las tapas cerradas.</p> <p>(3) Desechos verdes puestos en la banqueta dentro cajas o bolas as NO serán recogido.</p>	

<p>To request replacement and/or additional container(s) – Contact Ware Disposal Co Inc – 877-714-WARE (9273)</p> <p>County Of Los Angeles Department Of Public Works Monday – Thursday 7:00a.m. to 5:30 p.m. 1-800-993-5844</p>	<p>Para Reemplazar y/o pedir bota(s) adicionales llame a Ware Disposal Co Inc 877-714-WARE (9273)</p> <p>Condado de Los Ángeles Departamento de Trabajos Públicos Lunes – Jueves 7:00a.m. a 5:30 p.m. 1-800-993-5844</p>
--	--

DUMPSTERS (BINS)

Ware Disposal Inc. possesses enough bins as part of its ongoing rolling stock to handle the work associated with the Lennox Garbage Disposal District.

DUMPSTER (BIN) LABELS

Below, please find the bin labels for the Lennox Garbage Disposal District.

Please place these items in the recycling bin

Por favor coloque estos artículos en el contenedor de reciclaje

<p>Office Paper <i>Papel De Oficina</i></p> 	<p>Aluminum, Tin, Metal, Bi-metal <i>Aluminio, Lata, Bi-metálico</i></p> 	<p>Glass <i>Vidrio</i></p> 	<p>Plastics <i>Plásticos</i></p> 	<p>Clean, Small, Pieces of Wood <i>Pedazos Pequeños De Madera</i></p> 	
<p>Newspapers, Magazines, Junk Mail <i>Periódicos, Revistas y Correo No Deseado</i></p> 	<p>NO:</p> <p>Food Waste <i>Desperdicios De Comida</i></p> <p>Construction Material <i>Materiales De Construcción</i></p> <p>Hazardous Waste <i>Residuos Peligrosos</i></p>		<p>Yard Waste <i>Desperdicios Verdes</i></p> <p>Appliances and Electronics <i>Aparatos de hogar Y Electrónicos</i></p> <p>Clothing/Linen <i>Ropa/ Telas</i></p>		<p>Cardboard and Dry Food Boxes <i>Cajas De Cartón y de Alimentos</i></p> 













NO Hazardous Waste



**Please do not place hazardous waste materials in this bin.
Examples of items that are prohibited include:**

<ul style="list-style-type: none">• All batteries• Paint• Pesticides• Household cleaners/chemicals• Vehicle fluids (antifreeze, motor oil, etc.)	<ul style="list-style-type: none">• Prescription drugs• Sharps (syringes, lancets)• All other hazardous waste labeled toxic, poison, corrosive, flammable, combustible or irritant
--	--

NO:





Residents may dispose of these materials for free by contacting (888) CleanLA or visit www.CleanLA.com



WARNING

NO SCAVENGING

**DO NOT REMOVE MATERIALS
PUNISHABLE BY FINE UP TO \$5,000**

Los Angeles County Code § 20.72.196
California Public Resources Code § 41953



ADVERTENCIA

NO SE PERMITE REBUSCAR

**NO REMUEVA MATERIALES
CASTIGABLE CON MULTA DE HASTA \$5,000**

Código del Condado de Los Angeles § 20.72.196
Código de Los Recursos Públicos de California § 41953

CONTAINER PLACEMENT GUIDELINES



- Carts must be placed directly in front of the residence with wheels touching the curb
- Place carts at least 18" apart from each other
- Weight Limits
 - 96 gal = 250 lbs.
 - 64 gal = 150 lbs.
 - 32 gal = 100 lbs.

Note: Based on cart specifications.

Exhibit 3D-Contractor Documentation

Item A.4 – VEHICLE SPECIFICATIONS

This item consists of 18 pages (including this page).

The vehicles listed below are assigned to perform Task 1 and Task 2 services in the Lennox service area.

Collection Vehicles List for Lennox

Vehicle number		Fuel	Model	Description	Year	Make	Material
140		CNG	Autocar	Sideloader VIN 5VCACRLE0BH211701	2011	Xpeditor	Refuse, Recycling, Green
142		CNG	Autocar	Sideloader VIN 5VCACRLE2BH211702	2011	Xpeditor	Refuse, Recycling, Green
143		CNG	Autocar	Sideloader VIN 5VCACRLE4BH211703	2011	Xpeditor	Refuse, Recycling, Green
145		CNG	Autocar	Sideloader VIN 5VCACRLE6BH212271	2011	Xpeditor	Refuse, Recycling, Green
144		CNG	Autocar	Sideloader VIN 5VCACRLE1BH212291	2011	Xpeditor	Refuse, Recycling, Green
141		CNG	Autocar	Sideloader VIN 5VCACRJF39H209625	2009	Xpeditor	Refuse, Recycling, Green
77		CNG	Peterbilt	Sideloader VIN 3BPZL20X48F718638	2008	320	Refuse, Recycling, Green
78		CNG	Peterbilt	Sideloader VIN 3BPZL20X68F718639	2008	320	Refuse, Recycling, Green
79		CNG	Peterbilt	Sideloader VIN 3BPZL20X28F718640	2008	320	Refuse, Recycling, Green
80		CNG	Peterbilt	Sideloader VIN 3BPZL20X48F718641	2008	320	Refuse, Recycling, Green
81		CNG	Peterbilt	Sideloader VIN 3BPZL20X68F718642	2008	320	Refuse, Recycling, Green
82		CNG	Peterbilt	Sideloader VIN 3BPZL20X69F718643	2008	320	Refuse, Recycling, Green
83		CNG	Peterbilt	Sideloader VIN 3BPZL20X29F718719	2008	320	Refuse, Recycling, Green
104		CNG	Peterbilt	Front End Load VIN 3BPZL20X69F719355	2009	320	Refuse, Recycling, Green
10		CNG	Isuzu	Flat bed VIN 54DC4W1C4CS804531	2012	Flat Bed	Bulky Items
43		CNG	Isuzu	Flat Bed VIN 54DC4W1C6CS804532	2012	Flat Bed	Bulky Items

Autocar Specifications



An ISO 9001:2000 Certified Company

Autocar Xpeditor 6x4 Key Specifications

Engine and Equipment

Engine model	Cummins 2013 ISL9 rated from 300 hp to 370 hp Cummins 2013 ISX12 rated from 350 hp to 425 hp Cummins SL G (natural gas) rated from 300 hp to 320 hp Cummins SK12G (natural gas) rated at 350 hp
Exhaust Diesel	Horizontally mounted DPF with LH vertical SCR Horizontally mounted DPF with RH vertical SCR
Exhaust Dies	LH vertical 3-way catalytic converter RH vertical 3-way catalytic converter Horizontal exhaust with rail mounted 3-way catalytic converter
Air cleaner	15 inch single stage EPG 15 inch single stage with safety element EPG 16 inch 2 stage
Radiator	1300 sq inch aluminum
Fan & drive	2 speed fan drive
Coolant hoses/piping	Saeco hoses with constant tension clamps
Coolant	Extended life coolant

Transmission and Equipment

Transmission model	Allison 3000 RDS (not available with ISX12) Allison 4000 RDS
Transmission gearing	5 or 6 speed
Transmission controls	Allison push button
Transmission cooler	Remote oil to coolant shell and tubefloating bundle
Transmission lubricant	Transynd synthetic auto trans fluid
Driveshaft	Dana Spicer/Balfour round, yoke size 1710, 1780 or 1810 dependent on transmissions and driveline rotational speeds

Front Axle and Equipment

Axle model	Meritor MF0-24 Meritor MF0-11 Meritor MF0-12 Dana F-2200W
Front suspension	6,500 lb Flat leaf rated at 14,500 lb capacity 7,500 lb Flat leaf rated at 16,500 lb capacity 8,500 lb Flat leaf rated at 18,500 lb capacity 9,500 lb Low camber flat leaf rated at 20,500 lb capacity 10,100 lb Flat leaf rated at 22,000 lb capacity 10,200 lb Taper leaf rated at 22,000 lb capacity
Power steering	TAS 65 with assist ram
Brakes	Meritor 18.5 x 4 QP Meritor 18.5 x 7 QP Meritor 18.5 x 7 SSSJ Meritor EX 225 air disc

Rear Axle and Equipment

Axle model	Meritor MT40-14X Meritor MT40-14X with 1/2 inch housing Meritor MT44-14X Meritor RT45-550 Meritor RT45-554 Meritor RT52-555
Rear axle ratio	4.39 to 6.14 Dependent on axle model, vehicle configuration and application
Rear suspension	Haulmax HW2-400 at a 54 inch axle spread, rated at 40,000 lb capacity Haulmax HW2-400 at a 54 inch axle spread, rated at 45,000 lb capacity HMS22 at a 54 inch axle spread, rated at 52,000 lb capacity Pymax EX 462 Air Ride at a 54 inch axle spread, rated at 46,000 lb capacity

Ware Disposal Inc.

Lennox GDD

Brakes	Meritor 16 5x7 QP Meritor 16 5 x 8 62 QP Meritor 16 5 x 8 62 SSO Meritor 16 5 x 7 P cast shoe Meritor EX-225 Air Disc
--------	---

Chassis and Equipment

Wheelbase	Available in 3 inch increments between 143 inch and 269 inch
Frame	3/8 inch Variable drop rail. 120 kPsi heat treated steel, RBM of 3,259,000 lb in to 4,220,000 lb in dependent on drop configuration and liners
Heavy duty front end	Available for severe duty service applications such as snow plowing
Tow device	Two tow pins integral with front crossmember

Cab and Equipment

Cab construction	The cab is constructed from corrosion-resistant steel followed by a Cathodic Electrocoat dip process before the top coat is applied
Cab drive configuration	Single LH drive Single RH drive Dual drive dual sit Dual drive RH standup Single LH drive RH standup
Cab doors	Steel doors with power or manual crank window regulators
Mirrors	Black or chrome plastic housing with dual pane mirrors. Options include power adjustment, heat and integrated marker lights
Cab climate control system	30,000 BTU air conditioner with heater
Steering column	Adjustable for tilt on single drive cab configurations
Steering wheel	16 or 18 inch Diameter
Driver seats	National Cush II low back air ride Sears C2 air ride Various Bostrom selections
Passenger seats	Fixed type low back Sears C2 fixed or air ride Various Bostrom selections



ACX 6X4 TYPICAL
 CUMMINS 15L ENGINE
 ALLISON 4500 TRANSMISSION
 40' STEER W/STEER
 40' STEER W/STEER
 HENDRICKSON HMX 46X REAR SUSPENSION
 20" WHEELBASE
 62" OVERHANG
 ALL DIMENSIONS IN INCHES

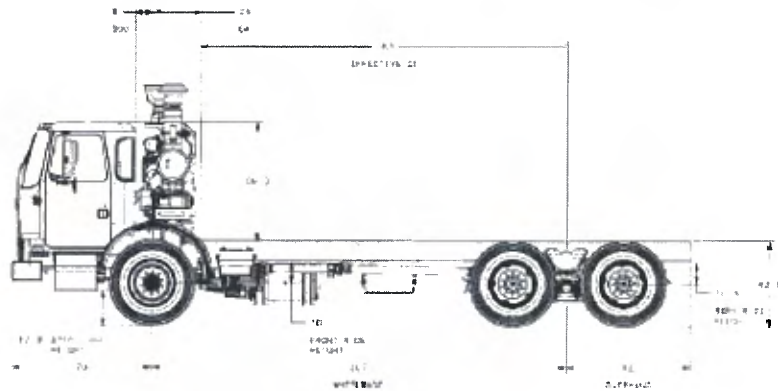
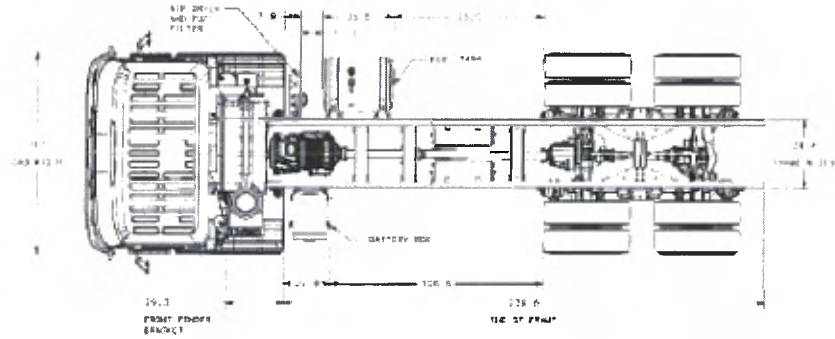

Ware Disposal Inc.

Lennox GDD

PETERBILT 320 SPECIFICATIONS



	Vocational
Cab	Steel Structure with Aluminum Skin and Fiberglass Roof
Hood	N/A
Sleepers	N/A
Seats	Driver: Peterbilt or Sears Passenger: Peterbilt, Sears or 2 Person
Engines	PACCAR PX-9 Cummins ISX12 Cummins Westport ISLG Cummins Westport ISX12G
Air Cleaner(s)	Single Back of Cab
Exhaust System	Single (Vertical)
Exhaust Guards	Stainless Steel - Vertical
Transmissions	Fuller Manual 10 or 13 Speed Allison Automatic 4, 5 or 6 Speed
Frames	10 3/4" Steel
Front Axles	Dana Spicer (12,000 lbs., 14,600 lbs. or 20,000 lbs.) Meritor (12,000 lbs. Single) Meritor (36,000 lbs. Tandem)
Front Springs	Taper Leaf
Front Hubs	Iron or Aluminum
Front Brakes	Air Disc or Air Cam Drum
Single Rear Axles	Dana Spicer (21,000 lbs., 23,000 lbs., 25,000 lbs., 26,000 lbs., 30,000 lbs.) Meritor (21,000 lbs., 23,000 lbs.)
Tandem Rear Axles	Dana Spicer (40,000 lbs., 44,000 lbs., 46,000 lbs., 52,000 lbs., 60,000 lbs.) Meritor (40,000 lbs., 44,000 lbs., 46,000 lbs.)
Tridem Rear Axles	Dana Spicer (69,000 lbs.) Meritor (66,000 lbs.)
Rear Hubs	Iron or Aluminum
Rear Brakes	Air Disc or Air Cam Drum
ABS Systems	Bendix 4S4M, 6S4M or 6S6M Air





Single Rear Suspensions	Peterbilt AirTrac Reyco 79KB Reyco 102 Reyco 102AR
Tandem Rear Suspension	Peterbilt Air Trac Peterbilt Air Leaf Peterbilt Low Air Leaf Hendrickson HN Hendrickson HMX Hendrickson RT Reyco 102 Chalmers 854 Neway
Tridem Rear Suspension	Peterbilt Air Trac Neway
Tires	Bridgestone, Goodyear or Michelin
Wheels	Steel or Aluminum 22.5" or 24.5"
Air Dryers	Bendix
Air Tanks	Steel or Aluminum
Chassis Hose	Nylon or Wire Braid
Air & Electric Mounting	Optional End of Frame
Fuel Tanks	23" Aluminum 50 - 120 Gallon 26" Aluminum 50 - 150 Gallon
Battery Box	Steel or Aluminum
Tool Box	Optional
Bumpers	Steel Painted or Chrome, Aluminum Polished

Please see your local Peterbilt dealer to use Peterbilt PROSPECTOR to specify options on your particular truck.



CUMMINS ISL G ENGINE SPECIFICATONS

Cummins Westport
The Natural Choice



ISL G



The Leading Natural Gas Engine For Truck And Bus.



Lower Emissions, Improved Performance, Lower Costs.

The ISL G is the natural choice in alternative-fuel engine technology. With industry leading performance and first fit OEM availability, it combines all the advantages of clean-burning, low-cost natural gas with the power and torque needed for shuttle and school bus, urban transit, vocational and medium-duty truck and tractor applications.

Since the ISL G was introduced in 2007, thousands of truck and bus customers have benefited from the impressive low-end torque, transient response and quiet operation of the ISL G. Today, the ISL G meets current U.S. Environmental Protection Agency (EPA) and California Air Resources Board (ARB) emissions standards, as well as EPA greenhouse gas (GHG) and U.S. Department of Transportation (DOT) fuel-consumption regulations.

Dedicated Factory-Built Natural Gas Engine

The ISL G is a dedicated, factory built natural gas engine, manufactured by Cummins on the same assembly line as the ISL9 diesel. It shares many components and parts with the Cummins L Series diesels, including the same full skinned block, for increased rigidity and strength. The design provides superior piston ring and bearing life, improved coolant flow and targeted-piston cooling. For improved reliability and durability the ISL G features a new heavy duty Exhaust Gas Recirculation (EGR) cooler, redesigned exhaust manifold and gaskets, improved turbo housing and water pump and a newly updated Ignitor Control Module (ICM) and sensors. Life-to-rebuild and rebuildability are similar to those of diesel engines.

Advanced Combustion Technology.

The 8.9-liter ISL G uses Stoichiometric cooled Exhaust Gas Recirculation (SEGR) combustion, leveraging Cummins power EGR technology to create a high-performance natural gas engine. Stoichiometric combustion is the theoretical or ideal combustion process in which fuel and oxygen are completely consumed, with no unburned fuel or oxygen in the exhaust.

The cooled-EGR system takes a measured quantity of exhaust gas and passes it through a cooler to reduce temperatures before mixing it with fuel and the incoming air charge to the cylinder.

Cooled EGR, in combination with stoichiometric combustion, provides significant benefits. The use of cooled EGR (in place of large amounts of excess air used in lean-burn technology) lowers combustion temperatures and knock tendency. SEGR combustion also improves power density and fuel economy versus lean-burn and traditional stoichiometric engines.

Maintenance-Free Aftertreatment.

Another benefit of the ISL G combustion technology is enabling the use of Three-Way Catalyst (TWC) aftertreatment. TWCs are effective, simple, passive devices, packaged as part of the muffler. They provide consistent emissions control performance, are maintenance-free and can be mounted vertically or horizontally on the vehicle. The ISL G does not require active aftertreatment such as a Diesel Particulate Filter (DPF) or Selective Catalytic Reduction (SCR).



Three-Way Catalyst Aftertreatment

Natural Gas - The Fuel Choice Is Yours.

The ISL G operates on 100 percent natural gas, which can be carried on the vehicle in either compressed (CNG) or liquefied (LNG) form. The ISL G can also run on renewable natural gas (RNG) made from biogas or landfill gas that has been upgraded to vehicle-fuel quality. To meet engine fuel requirements under a variety of load conditions, the engine requires the fuel storage system to provide at engine fuel pressure at rated conditions between 70 psi and 150 psi.





ISL G Ratings

Engine Model	Advised hp (kW) @ rpm	Peak Torque lb-ft (N·m) @ rpm	Governed Speed
ISL G 320	320 (239) @ 2100	1000 (1357) @ 1300	2200 RPM
ISL G 300	300 (224) @ 2100	850 (1160) @ 1300	2200 RPM
ISL G 280	280 (208) @ 2100	800 (1077) @ 1300	2200 RPM
ISL G 260	260 (194) @ 2100	660 (895) @ 1300	2200 RPM
ISL G 250	250 (188) @ 2100	730 (995) @ 1300	2200 RPM

ISL G Specifications

Maximum Horsepower	320 HP	239 KW
Peak Torque	1000 LB-FT	1357 N·m
Governed Speed	2200 RPM	
Clutch Engagement Torque	560 LB-FT	745 N·m
Type	4-cycle, spark-ignited, in-line 6-cylinder, turbocharged, CAC	
Engine Displacement	540 CU IN	8.9 LITERS
Bore and Stroke	4.49 IN x 5.09 IN	114MM x 128MM
Operating Cycles	4	
Oil System Capacity	7.3 U.S. GALLONS	27.6 LITERS
Coolant Capacity	13.1 U.S. QUARTS	12.4 LITERS
System Voltage	12 V	
Net Weight (Dry)	1,625 LB	737 KG
Fuel Type	CNG/LNG/RNG	Methane number 75 or greater
Aftreatment	Three-Way Catalyst (TWC)	

Features And Benefits.

- > **Air/Fuel Regulation** – Cummins closed-loop electronic control system based on Cummins Interact™ System. Improved sensors for engine parameters, including intake manifold pressure and temperature, fuel inlet pressure, knock detector, air/fuel ratio and fuel mass flow.
- > **Air Intake System** – Charge-air cooling reduces emissions by lowering intake manifold air temperatures.
- > **Accessory Belt Drive System** – Self-tensioning serpentine poly-vee belt accessory drive system for water pump, engine-mounted fan hub and most alternators. Gear-driven air compressor with provision for gear-driven hydraulic pump.
- > **High Energy Ignition System** – Improved ICM provides better performance and improved spark plug and coil durability, plus self-diagnostics.
- > **High-Efficiency Lube Cooler** – Lowers oil temperatures for longer engine life.
- > **Crankshaft** – Eight-counterweight, fully balanced, high-tensile-strength steel forging with induction-hardened fillets and journals, for outstanding durability.
- > **Oil Filter** – The combination full-flow and bypass oil filter improves filtration while minimizing oil filter replacement and disposal costs.
- > **Control System** – Full drive by wire Electronic Control Module (ECM) provides full monitoring and control of engine sensors, fuel system and ignition system. Full interface capability to Cummins INSITE™ and diagnostic service tools. ECM provides Original Equipment Manufacturers (OEMs) and end users with the ability to tailor performance of the engine to fit the vehicle's mission.
- > **Electronic Features Include:**
 - Road-speed governing
 - Accelerator interlock
 - SAE J1587/J1939
 - Power Take-Off (PTO) control
 - Cruise control
 - Engine protection system
- > **Farts Simplicity** – Enables most engine service and repair operations with common tools.
- > **Wastegate Turbocharger** – With water-cooled bearing housing for durability. Electronic control for precise air handling.

Gearing Recommendations.

For the best reliability and durability, the recommended maximum gross vehicle weight (GVW) for the ISL G is 66,000 lb (29,937 kg). Select gearing for fuel economy in regional-haul applications where engine speed is 1700-1800 rpm at optimal cruise. For vocational, transit and refuse applications, select gearing where engine speed is 1750-1900 rpm at cruise. Consult your Cummins or Cummins Westport representative to discuss specific gearing guidelines for your application.



Optimizing Performance With PowerSpec.™

Cummins PowerSpec helps you find the ideal gearing specs for engine performance or fuel economy, making it possible to tailor the operation of Cummins Westport engines to fit every customer's application. PowerSpec can also read fault codes, and can be programmed to collect trip information for multiple drivers. PowerSpec works on both ISL G and ISX12 G engines. See cumminsengines.com/powerspec for more information.

Base Warranty.

Cummins Westport engines feature the same factory base warranty coverage as Cummins diesel engines. For transit bus and shuttle engines, a standard 2 year/unlimited mileage/kilometers warranty with full parts and labor coverage on warrantable failures* applies.



For school bus engines, standard coverage is 5 years/100,000 miles (160,934 km), whichever comes first. Major components are covered for 2 years/300,000 miles (482,803 km), whichever comes first.

For truck customers, full engine coverage is provided for 2 years/250,000 miles (402,336 km), whichever comes first.

*Warrantable failures are those due to defects in materials or workmanship.

Extended Coverage.

For additional peace of mind, Cummins Westport offers a variety of extended coverage plans to meet every customer's need. For full extended coverage plan details, contact your local Cummins distributor or Cummins Westport representative.



Better Customer Care.

Cummins Westport-powered vehicles are supported by Cummins service network, the largest and most capable in North America. Cummins-authorized technicians are fully trained on Cummins Westport natural gas engines with ready access to Genuine Cummins parts and warranty support. For questions regarding your Cummins Westport engine or for assistance in finding a repair facility in the United States or Canada, call Cummins Care at 1-800-DIESELS™ (1-800-343-7357).

Cummins Westport - The Natural Choice.

Cummins Westport Inc. designs, engineers and markets 6- to 12-liter spark-ignited natural gas engines for commercial transportation applications such as trucks and buses. Our dedicated 100 percent natural gas engines are manufactured by Cummins, and are available as a factory-direct option from leading truck and bus manufacturers.



The Natural Gas Academy.

To learn more about natural gas engines for transportation, and how natural gas can work for your fleet, visit the Cummins Westport Natural Gas Academy online. You'll find videos, information and resources about engines, OEM availability, fuel systems, refueling, maintenance and more: cumminswestport.com/natural-gas-academy

Maintenance Intervals

ISL G Truck < 66,000 GVW

Maintenance Item	Miles/Kilometers	Hours	Months
Oil and Filter*	15,000 MI 24,000 KM	100	6
Fuel Filter	30,000 MI 48,000 KM	1,000	12
Coolant Filter	15,000 MI 24,000 KM	500	6
Spark Plugs	45,000 MI 72,000 KM	1,500	18
Change Coolant	60,000 MI 96,000 KM	2,000	24
Valve Adjustment**	60,000 MI 96,000 KM	2,000	24
Air Cleaner/Element	Follow vehicle manufacturer's published recommendations		

*Requires natural gas engine oil (CEC 20074).
 **Initial valve adjustment at 1,000 hours

ISL G Torque Curves

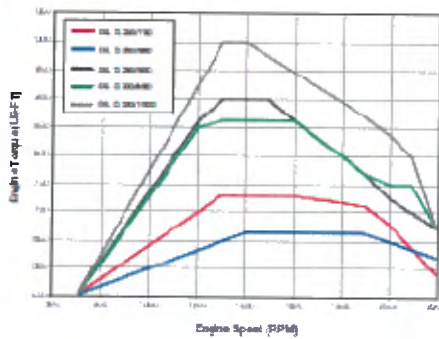

Cummins Westport is a pioneer in product improvement. Thus specifications may change without notice. Illustrations may include optional equipment.

Maintenance Intervals

ISL G Urban Transit Bus And Refuse Truck

Maintenance Item	Miles/Kilometers	Hours	Months
Oil and Filter*	7,500 MI 12,000 KM	500	6
Fuel Filter	15,000 MI 24,000 KM	1,000	12
Coolant Filter	7,500 MI 12,000 KM	500	6
Spark Plugs	22,500 MI 36,000 KM	1,500	18
Change Coolant	30,000 MI 48,000 KM	2,000	24
Valve Adjustment**	30,000 MI 48,000 KM	2,000	24
Air Cleaner/Element	Follow vehicle manufacturer's published recommendations		

- > Default intervals (in hours) stated. Interval is whichever comes first (hours, miles or time).
- > Refer to QuickServe® Online or Owner Manual for complete details on maintenance intervals.
- > Based on normal duty cycle of 10 mph average speed. Distance intervals will increase or decrease based on average speed.



Introductory Vehicle Billboard Example:



MOBILE TECHNOLOGY



EASILY VIEW ROUTES, STOPS & GPS TRACKING

Map-Pak works on the Google Maps™ platform, the most powerful and cost effective mapping application on the market. Easily view and display all routes and their stops from the Soft-Pak dispatching center. Click on any stop to verify account information while easily identifying overlapping stops to improve route efficiencies. Take advantage of Google Maps™ route optimization to re-sequence and improve route performance and profitability. All data flows back to Soft-Pak for easy accountability and back office reporting.

Map-Pak and **Mobile-Pak** work together by displaying the location of all active mobile devices. Each driver's GPS location is sent to Soft-Pak in real time, providing instant vehicle verification and playback purposes to insure driver efficiencies.



Identify your different routes in real time with **Mobile-Pak**. Red is route C1, Blue is an route R1 (see above)

THE BENEFITS TO **Map-Pak**:

- Visually display routes in various colors
- No software to load
- Everything is run via 'the cloud'
- Utilize Google Map™ for terrain, traffic, or satellite views
- Live traffic updates for drivers and dispatching
- Geo Code directly from hand held to 'pin point' a stop
- Route optimization and re-sequence via Google Maps™
- Display and record all driver activities for playback purposes
- Increased customer service with driver and route verification

3550 Camino Del Rio North, Suite #208 - San Diego, CA 92108 • Tel: 888.763.8725
 sales@soft-pak.com • www.soft-pak.com

Ware Disposal Inc.

Lennox GDD



Mobile-Pak

IN-TRUCK COMPUTING MADE EASY AND AFFORDABLE

EXTEND THE VALUE OF YOUR **i-Pak** OR **e-Pak** APPLICATION WITH **Mobile-Pak**

With **Mobile-Pak**, drivers can easily view and scroll through their route list, update customer activity, verify extra services and locate their next stop. The driver's GPS location and all route activity is sent to **i-Pak** or **e-Pak** in real time, updating service information in the customer's account as well as productivity, work orders, billing and route follow-up.

Mobile-Pak is designed on the Android tablet platform, allowing any size tablet to be mounted in the cab for easy viewing/one click use. The mobile tablets allow for signature capture or picture taking with the images available in the customer's account. Tablets also connect to onboard scales to verify container weight and auto completes are an option for high density routes.

Mobile-Pak provides reliable/easy to use in-cab computing that improves efficiency for roll off, liquid waste, commercial and residential drivers.



Easy one-click 'COMPLETE' or 'HOLD' for Roll off, Commercial & Residential Routes



An affordable and proven tablet solution that provide efficiencies to both driver and back office

Mobile-Pak COMES WITH:

- Scheduled and on call work sent instantly to the drivers
- GPS vehicle display with viewable map to locate next stop
- Picture taking for any service related issues
- Capture signatures for customer verification or contracts
- Geo Code each stop for route management
- Enter scale/ticket information from disposal facility
- Auto Complete feature for larger high density routes
- Driver activity board to manage route & driver behavior
- Connect to On-board Scales to capture weights
- Works with any size Android tablet
- Optional rugged tablets for increased durability

8525 Gibbs Drive #300, San Diego, CA 92123 • Tel: 888.763.8725
 sales@soft-pak.com • www.soft-pak.com

Mobile-Pak integration with i-Pak/e-Pak

Customer Service

- **Sales History tab** – updated with date of service, day, arrival time, depart time, complete/skip code, weight (from on board scales), latitude/longitude (geo code) of service
- **Services tab** – updated with date of service, day, arrival time, depart time, complete/skip code, weight, latitude/longitude (geo code) of service
- **Services tab** – updated with photos taken from mobile-Pak
- **Services tab** – route history – users can click on a day/route to see the route status and last sequence number that was serviced
- **Work Orders** – photos and terms & conditions that have been signed for that work order from mobile-pak are always available to view in that work order
- **Note Pad** – notes from mobile-Pak update the note pad
- **Sales & Adjustments** – any extra charges the drivers enter from mobile-Pak get posted as a sales adjustment batch

Accounting

- **Route Follow up** – weights, time of service, extra services/charges and notes are populated from mobile-Pak and edited/posted to the customers' accounts.

Operations

- **Dispatching** – work orders get updated with colors when drivers complete or skip a work order type job
- **Dispatching** – users can see any work orders that have been dispatched from e-Pak but not picked up by the drivers tablets (pending mobile-Pak work orders)
- **Dispatching** – Dispatch can send messages to drivers
- **Dispatching/work order lists** – Dispatching work orders or running work order lists creates the work order data for mobile-Pak to load
- **Dispatching** – The process of dispatching a work order will send it to the tablet (very important for same day service requests, important jobs than need to be done ASAP, etc.)
- **Route Lists** – Running route lists will create the scheduled route list data for mobile-pak to load (on call work orders can also be included with this process)
- **Temporary Route Splits** – Can move stops from one route to another route for drivers that need help (will take stops from original mobile-Pak tablet and productivity and move to the mobile-Pak tablet and productivity of the helper route)
- **Route Status Display** – Displays current sequence/stop number, route status, last service address, route notes, and if there are pictures for that route. Access to OBC detail from this screen
- **View Route Activity** – screen to filter information across all routes (by skips, completes, extras, disposal data, driver activities, messages, logins, notes, paused stops and photos)

- View Route Activity – for routes that are not sequenced, can sequence the route in the order the driver did the route that day
- OBC Activity/Audit Report (printed or into excel)
- OBC Driver Activity Report (printed or into excel)
- OBC resequencing – If a driver has changed a sequence number from Mobile-Pak, ability to push the new sequence numbers to that account or delete
- OBC Route download activity – view/verify data that has been sent to each mobile-Pak tablet
- Pre/Post vehicle inspection reports – Set up drivers pre/post requirements on the mobile-pak server and generate pre/post vehicle inspection reports
- Mobile-Pak dashboard – see all mobile-Pak route data in real time for operations to make on the fly decisions about routes and reallocating route resources
- Mobile-Pak configuration – set up mobile-Pak templates by vehicles, routes, route types, so when a certain type of vehicle logs in, all tablet settings/permissions are defaulted

Map-Pak

- See real time Mobile-Pak GPS data in Map-Pak
- See vehicle trail of all GPS pings for a mobile-Pak vehicle
- See all mobile-Pak events (Skips, completes) in Map-Pak

Productivity

- Drivers logs – Mobile-Pak updates start odometer, start time, service/delay code, in serial #, out serial #, arrive customer time, arrive disposal site time, depart disposal site time, depart customer time, disposal site, disposal ticket number, material, tonnage, end odometer and end route time
- Route Costing – Mobile-Pak updates start odometer, start time, arrive disposal site time, depart disposal site time, stop time, disposal site, disposal ticket number, material, tonnage, downtime/activities, end odometer and end route time

Web-Pak

- Photos from mobile-Pak can be displayed in Web-Pak for your customers to sign in and view.
- Route History – (future development) see past service information from mobile-Pak in Web-Pak (date of service, time of service, completed/skipped)

Miscellaneous

- Messages – The message screen will pop up for dispatcher when a message is received from a driver or when the driver logs out with stops that have not been completed



Invoice Date 03/01/2018
 Invoice Number 211459
 Invoice Total 53750.00
 Customer Number 1-11913
 Due Date

WARE DISPOSAL
 1035 E 4TH ST
 SANTA ANA CA 92701

Service Address
 WARE DISPOSAL
 1035 E 4TH ST
 SANTA ANA CA 92701

Date	Description	Quantity	Rate	Total
03/01/18	20 MOBILE-PAK LICENSES	20.00		43000.00
03/01/18	REQUESTED AND APPROVED BY-			
03/01/18	MICHAEL SHAFFER			
03/01/18	*			
03/01/18	ADDITIONAL SUPPORT FEES FOR			
03/01/18	MARCH 1, 2018 - FEBRUARY 28, 2019			
03/01/18	SUPPORT FEES			10750.00
03/01/18	*			
03/01/18	THANK YOU FOR YOUR BUSINESS!			

Payment is Due Upon Receipt
 Thank You
 We now accept payments online. Visit our
 website at WWW.SOFT-PAK.COM
 Your access code is 0101592

Total Invoice 53750.00
Please Pay
 53750.00

For proper credit please fill out and return the below portion

Invoice Date 03/01/2018
 Invoice Number 211459
 Customer Number 1-11913
 Due Date

Please Pay \$53750.00
 Amount Enclosed \$

WARE DISPOSAL
 1035 E 4TH ST
 SANTA ANA CA 92701

SO. CAL SOFT-PAK, INC.
 8525 GIBBS DR
 SUITE 300
 SAN DIEGO, CA 92123

*Ware Disposal Inc. already possesses the Mobile Paks and is not awaiting delivery of said.

Exhibit 3D-Contractor Documentation

Item A.5 – SUBCONTRACTOR

This item consists of 1 pages (including this page).

None to report.

Ware Disposal Inc.

Lennox GDD

Exhibit 3D-Contractor Documentation

Item A.6 – OFFICE

This item consists of 1 pages (including this page).

Office: 1035 East 4th Street, Santa Ana, California 92701 4750

Hours: Monday through Friday – 7:00 a.m. to 5:00 p.m.
Saturday – 7:00 a.m. to 1:00 p.m.

Repair Shop/Vehicle Yard: 1451 Manhattan Avenue, Fullerton, California 92831 5221

T 877 714 9273

F 714 664 0696

www.waredisposal.com

Exhibit 3D - Contractor Documentation

Item B.1 – FORM ON NON-COLLECTION NOTICE

This item consists of 2 pages (including this page).

B.2 Form of Non-Collection Notice



NON-COLLECTION NOTICE

- 1. Unpermitted waste such as household hazardous waste, electronic waste, batteries and fluorescent tubes were placed in the containers. Contact the County of Los Angeles hotline at 1 888 CLEAN LA or visit their website at www.CleanLA.com for more information.
- 2. Due to unsafe service conditions.
- 3. ALL waste must be inside containers provided to you with the exception of pre-arranged bulky or excess item pick-ups.
- 4. Your containers or bulky item waste was not set out at the collection set out site.
- 5. Your container exceeds weight limitations as identified on the terms and conditions section of the Subscription Notice.
- 6. Your account is past due.
- 7. Premises are not safely accessible to vehicles.
- 8. Your recyclables (blue) is contaminated with trash and/or recyclables, and/or manure.
- 9. Your organics container is contaminated with trash and/or recyclables, and/or manure.
- 10. Your trash container is contaminated with manure.
- 11. Your manure container is contaminated with trash and/or recyclables, and/or organics.
- 12. Other: _____

If the above is corrected by 12:00pm today, please contact our customer service center on 877 714 9273 and we will return and collect today at no charge.

|

Ware Disposal Inc.

Lennox GDD

Exhibit 3D - Contractor Documentation

Item B.2 – WAIVER OF LIABILITY

This item consists of 2 pages (including this page).

**GENERAL RELEASE AND WAIVER OF LIABILITY
FOR DAMAGE TO PRIVATE DRIVEWAYS STREETS, PARKING LOTS, DRIVEWAYS, PAVEMENT
AND PERSONAL INJURY**

- 1. **PERMISSION TO ENTER.** Customer allows [Contractor Name] to enter and/or utilize the premises of the undersigned Customer for the purposes of providing the Solid Waste Collection services described on the attached Subscription Order. [Contractor Name] agrees to provide Solid Waste Collection services by use of the following:
 - Standard Collection Vehicle Special Collection Vehicle Other _____

- 2. **WAIVER OF LIABILITY.** [Contractor Name] is obligated and liable to Customer under its Exclusive Franchise Contract with the County, including Part 9C of Exhibit 5, and item B of Section 4 of said Contract, to repair or replace to the satisfaction of the Customer, any physical damage to public or private property, driveways or other pavement, and shall reimburse to the satisfaction of the Customer the cost of any personal injury, caused by [Contractor Name] negligence or willful acts or omissions. [Contractor Name] and Customer shall indemnify and hold COUNTY harmless from liabilities related to entering Customers' Premises.

- 3. **BINDING.** This acknowledgement, hold harmless, and release/assumption of risk shall be binding on all of Customer's successors and administrators for the term of the Contract with the County.

CUSTOMER INFORMATION

In signing this permission and release/assumption of risk/waiver, I hereby acknowledge and represent:

- That I have read this release, understood it and signed it voluntarily; and
- That I am the legal Customer or authorized agent paying for services at the premises at the address provided below.

Customer or Authorized Agent's Printed Name	Name of Business (N/A for residential)
Customer or Authorized Agent's Signature	Date
Service Location Street Address	Property Owner's Street Address (if different)
Service Location City & ZIP	Property Owner's City, State & ZIP (if different)

CONTRACTOR INFORMATION

[Contractor Name] Authorized Agent Printed Name	CONTRACTOR's Name
[Contractor Name] Authorized Agent's Signature	Date

Ware Disposal Inc.

Lennox GDD

Exhibit 3D - Contractor Documentation

Item B.3 – TERMS AND CONDITIONS SUMMARY

This item consists of 3 pages (including this page).



Rate Sheet

August 13, 2018

To Our Valued Lennox Garbage Disposal District Customer:

The County of Los Angeles Board of Supervisors awarded Ware Disposal, Inc. a contract to provide trash, recycling, and green waste collection services in the Lennox Garbage Disposal District. The term of this contract is 7 years with two 18-month renewal options for a potential total contract term of 10 years. The initial 7-year term commences on August 13, 2018.

All property owners in the Lennox Garbage Disposal District are enrolled to receive trash, recycling, and green waste services from Ware Disposal, Inc., which are assessed on the annual property tax bill. **Please note that the District does not provide service fee reimbursements to property owners who choose to receive services from a different waste hauler.** For information regarding services available to you, please call Ware Disposal, Inc.'s Customer Service Department at (877) 714-9273, Monday through Friday, 8 a.m. to 5 p.m. and Saturday, 8 a.m. to 12 p.m.

In addition to services assessed and paid for through the annual property tax bill, other services may be requested. Such services are listed below and are available for a fee, which will be billed by and paid directly to Ware Disposal, Inc. A Senior Discount of 25% off the additional services fees will be given to single family and duplex customers who meet the following criteria: head of household, 62 or older, and who either (a) qualify for utility rate discounts based on financial need or (b) generate small amounts of waste and use a 32-gallon cart for trash. Please call Ware Disposal, Inc.'s Customer Services Department to request for these services.

Additional Services and Surcharges: These services are available upon request.

Recyclables Cart with Gravity Lock (one-time charge)	\$25.00 (\$18.75 with senior discount)
Additional Containers Above Basic Service, each:	
For Carts:	
Trash (beyond 1 cart)	\$15.31/month (\$11.48/month with senior discount)
Recycling (beyond 2 carts)	\$2.84/month (\$1.86/month with senior discount)
Green Waste (beyond 2 carts)	\$6.43/month (\$4.82/month with senior discount)
For Dumpsters:	
Trash (for every additional ½ cubic yard)	\$15.31/month
Recycling (for every additional ½ cubic yard)	\$2.84/month
Green Waste (for every additional ½ cubic yard)	\$6.43/month
Container Size Exchange (beyond 1 per year):	\$12.29/exchange
Additional (beyond three/year) on-call collection of bulky items, excess trash, and excess green waste:	\$18.44/collection (\$13.83/collection with senior discount)
Difficult to Service: For any customer who requests this service or for difficult-to-service residential premises (such as hills or cul-de-sacs where collection vehicles cannot safely drive):	\$12.29/month (\$9.22/month with senior discount)
Roll-out/backyard service for Customers Receiving Services in Wheeled Plastic Carts (hauler brings carts to the curb to be serviced by collection vehicle and returned to the back yard or other designated location for an additional monthly fee of:	Elderly or disabled customers: Free Minimum Service (0 to 10 Feet): \$1.23 (\$0.92 with senior discount) Full Service (11 Feet to 50 Feet): \$6.15 (\$4.61 with senior discount)

TERMS AND CONDITIONS

What We Will Collect. We will collect trash, recyclables, and green waste in containers we provide. You must place these materials in the appropriate containers. Materials placed outside of containers will not be picked up unless previous arrangements have been made.

We Will Not Collect Hazardous Waste. State law prohibits disposal of hazardous materials and certain electronic devices in your containers. These include: most paints, pesticides, petroleum derivatives such as motor oil and solvents, electronic devices such as cathode ray tubes (as in TV and computer monitors), LCD and plasma screens. Other items banned from disposal include: batteries, thermostats, computers, telephones, answering machines, radios, stereo equipment, tape players/recorders, phonographs, videocassette players/recorders, calculators, aerosol cans, fluorescent lights, and certain mercury-containing devices. If these items are identified in your trash, your container will be tagged and not serviced. Certain electronic devices may be separately collected. For additional safe and legal disposal options, call 1(888) CLEAN LA or visit www.CleanLA.com.

How to Request Container Replacement/Repair. We will replace or repair broken containers within 2 days of customer's request without additional charge. Stolen containers will also be replaced within 2 days of customer's request without additional charge provided the customer submits a police report. Otherwise, customer will be charged a fee as listed on your rate sheet.

Alternative Container Size Exchange. We will exchange containers within 7 days of customer's request for alternative size container once per year at no additional charge. Requests for container exchanges beyond once per year will be charged a fee as listed on your rate sheet.

Difficult to Service. At a charge listed on the rate sheet, this service is available to difficult to service areas, such as cul-de-sacs or hills, where automated collection vehicles cannot safely drive or to any other customer upon request.

On-Call Pickups of Bulky Items and Excess Solid Waste. We will collect up to a total of 3 pickups per year, at no additional charge, items listed below that are set out at the curb on your next regularly scheduled pickup day if you call us at least 24 hours in advance.

Bulky Items. Maximum of 10 items per pickup. Examples of bulky items include discarded furniture (such as chairs, sofas, mattresses, box springs, and rugs); appliances (such as refrigerators, range, washers, dryers, water heaters, dishwashers, plumbing, and other similar items) and construction and demolition debris in up to two 70-pound containers.

Bagged Green Waste. Maximum of 10 bags/bundles per pickup. Green waste must be in bags or bound bundles less than 4 feet in length.

Bagged Trash. Maximum of 5 bags per pickup. Trash must be in bags.

Additional On-Call Pickups of Bulky Items and Excess Solid Waste. We will collect bulky items and excess solid waste, in excess of three times per year, on your next regularly scheduled pickup day, at the charges listed on your rate sheet, if you call us at least 24 hours in advance.

Holiday Tree Pickups. We will collect your holiday trees (such as Christmas trees and Hanukkah bushes) placed at the curb on your regularly scheduled collection day during the period of three weeks following December 25th. You must strip them of ornaments, garlands, tinsel, flocking and stands.

Additional Customer Options Regarding Recyclables. Customers may donate or sell any or all of their recyclables to persons other than this waste hauler.

How Much We Will Charge. We will charge all our customers the rates shown on the Rate Sheet for any additional requested services.

When You Must Pay. Customers who request additional services will be billed for these services three months in advance. We mail you your bill on or after the first day of your billing period, for example, on April 1 for the billing period of April, May, and June. Your bill is due no later than the last day of the first month, for example, on April 30. If we do not receive payment by the last day of the second month, for example, on May 31, your bill will become delinquent and an additional 10% fee will be added to the balance. We may terminate your service by the end of the third month and your containers will be removed. A \$25.00 interruption of service fee will be charged to restart service and a \$25.00 fee will be charged for returned checks.

Customer Termination Rights and Right To Self-Haul. You may terminate service without cause at any time by giving us 21-day notice. You also have the right to self-haul your waste instead of subscribing to our service.

Additional Information for Customers Receiving Services in Wheeled Plastic Carts

When We Will Collect. We will service cart customers once per week, between the hours of 6:00 a.m. to 6:00 p.m. on the same day, Monday through Friday, each week. If your scheduled collection day falls on or after a holiday, collection will be delayed during the holiday week by one day (Friday customers will have their collection on Saturday). The holidays we observe are Memorial Day, Independence Day, Labor Day, Thanksgiving, Christmas, and New Year's Day. Should there be a permanent change in your scheduled collection day, we will notify you in advance. If we miss your collection, please call us and we will return to pick it up, without charge, on the same day if you call before 12:00 p.m. or on the next collection day if you call after 12:00 p.m.

Where We Will Pick Up. On your scheduled collection day, cart customers must place carts at the agreed set-out site with carts facing the street and 18 inches apart from each other. Handles and wheels must be facing the curb. If we agreed to collect on private driveways or pavement, we will ask you to sign a waiver of damage liability and/or indemnification. Carts must only be placed at the set-out site for collection within the hours of 5:00 p.m. on the day before scheduled collection and 8:00 p.m. on the day of collection or 2 hours after collection, whichever is later.

How to Receive Roll-Out Service. We can bring your carts out to the pickup point, at no additional charge, for single family and duplex customers who certify they are not able-bodied or are elderly (over the age of 62) and have no able-bodied person residing in their household. Roll-out service will be provided to these customers during their weekly collection of trash, recyclable materials, and organics, as well as during the annual curbside clean-up event, holiday tree pick-ups, and additional on-call pickups. These services are also available to any other customer upon request at the charge listed on the rate sheet. We will ask you to sign a waiver of damage liability and/or indemnification prior to providing this service.

Weight Limitations of Carts. The weight limit for each automated cart is as follows: 96-gallon cart = 250 lbs., 64-gallon cart = 150 lbs., 32-gallon cart = 100 lbs. If carts are found to be over these weight limits, they will be tagged and not serviced.

To receive additional information regarding these terms and conditions or your service, please call us toll-free at (877) 714-9273, Monday through Friday, from 8 a.m. and 5 p.m., except holidays, and from 8 a.m. to 12 p.m. on Saturday. If we do not satisfactorily resolve any complaint, you may call the County at 1-888-CLEAN LA (or 253-2652).

Exhibit 3D-Contractor Documentation

Item B.4 – UN-PERMITTED WASTE SCREENING AND REPORTING

This item consists of 7 pages (including this page).

Unpermitted Waste Screening Protocol: The purpose of Ware Disposal Inc.'s Unpermitted Waste Screening Protocol is to prevent prohibited wastes from entering the waste stream through any of the weekly collection services or special services provided by Ware Disposal, or to manage wastes collected pursuant to the contract. Fully automated collection systems protect worker health and safety by creating a buffer between worker and waste. These systems also make it more difficult to detect the entry of prohibited wastes into the waste stream. This program is an important component of the Ware Disposal effort to assure the highest level of service to the assigned area's customers. Our method is as follows:

Ware Disposal drivers are properly trained to identify any hazardous materials in containers. Drivers will be given regular refresher courses as well including simulation to assure adherence to training principles. There will be an initial training session with respect to unpermitted waste screening and response activities, with refresher and updates on a quarterly basis. There will be cameras in the packer compartment of the truck that will aid the driver in identifying the presence of unpermitted wastes and materials during tipping activities. Ware Disposal will augment this with periodic checks of all vehicles and drivers by the route and/or field supervisor. In the event of unpermitted waste, we shall use several sequential steps to resolve the situation with the customer:

First occurrence

- Cart will not be emptied;
- Cart will be tagged with a non-collection notice;
- Customer service will notify customer by phone or mail that further contamination will result in non-collection.

Second occurrence

- Cart will not be emptied;
- Cart will be tagged with non-collection notice;
- Field or route supervisor will meet with resident to discuss the problem.

Third occurrence

- Cart will not be emptied;
- Cart will be tagged with non-collection notice;
- Field or route supervisor will meet with resident to discuss the problem;
- County will be notified and any further action will be at the County's direction.

In the event there are unsafe and/or hazardous materials in the containers, if safe enough to handle with conventional equipment and procedures, it will be removed and customer will be given the County's HHW round up number (1 888 CLEAN LA) to call to find out about the next convenient round up event. The County of Los Angeles' Household Hazardous and Electronic Waste collection program flyer will be left with the resident informing them of the next convenient round up event. The 1 888 CLEAN LA telephone number will be included on the tag as well.

Ware Disposal Inc.

Lennox GDD

To assist the community and customers with understanding what is safe and what is unsafe, Ware Disposal shall develop and implement a Safe Disposal Education Program. This program shall have two elements: home education and school education. The home education component shall consist of holding an annual town hall meeting and frequently updating of a well-publicized web site, delivery of an annual pamphlet describing the safe disposal program, use of magnets displaying the safe disposal message, a biannual convergent media message sent to each home identifying safe disposal procedures and safe alternatives to toxics, and provision of messaging on all on-hold callers identifying the availability of safe disposal opportunities and soliciting their participation. The school component will consist of updates to PTA and student assemblies on the issue of safe vs. unsafe disposal, and the provision of convergent media materials for use in the school curriculum extolling the benefits of safe disposal to all school aged children and youth.

Contamination audits: Ware Disposal will conduct contamination audits. Our specific protocol is as follows. Within the first six months of commencing the contract, Ware Disposal shall check all customers' recyclable carts and green waste carts once to ascertain whether customers are using their carts appropriately. This is defined as recyclables only in the recycling cart, and green waste only in the green waste cart. Checks will be conducted by having a team of employees trained to conduct inspections to observe the contents of each inspected cart by manually opening the lid of the cart or bin and visually inspecting the contents to identify potential contamination. This likely will take about a month to complete. Results will be tabulated and reported to the County on a house and route basis. Checking will be done after carts are placed at the curb, ready for collection. After the first six months of service, this procedure will be repeated annually for at least 20 percent of all carts on a rotating basis, such that all carts are checked at least once every five years. If Ware Disposal personnel observe contamination during the course of this or any other audit, we will leave a non-collection notice on the cart, and our dispatcher will be called and alerted to this event. Ware Disposal will follow up with a call to the residence to help them to understand why the cart wasn't collected and what they need to do to avoid non-collection.

Within two months, Ware Disposal shall recheck any residences that had contamination to assure that carts are free of contamination at collection. If not, a non-collection notice shall again be left, the dispatcher called, but customer services will follow up with a site visit to help train the resident in proper operation. It is noted that Ware Disposal shall provide a recap of all such audit activities in its monthly report.

In addition to these spot checks, Ware Disposal shall regularly check the extent of contamination from the post collection processing/marketing results. The desired level of residue will be set at about 10%. Anything above this level will be cause for Ware Disposal to send out information or other materials to help inform residents about contamination issues. The contamination audit will also be utilized to augment the existing unpermitted waste screening protocol.

Ware Disposal Inc.

Lennox GDD

Emergency Response Procedure: As it relates to employee response procedure when hazardous wastes are encountered during collection activities, the following represents Ware Disposal's policy.

First, Ware Disposal seeks to reduce this potential problem through public education and instruct residents that household hazardous waste they wish to discard should not be placed into their regular trash or recycling container. Residents will be encouraged to seek out public education assistance through www.888CleanLA.com and other media. Such wastes can be corrosive, toxic, ignitable, flammable or reactive and commingling them with their regular trash could create a dangerous situation. Much of their regular trash goes to landfills where household hazardous waste can contaminate soil and seep into ground water.

However, there are residents that do not heed such a public education warning. In the event that the refuse and/or recycling container is contaminated, Ware Disposal will notify the resident of such an occurrence. First notification is a non-collection notice on the cart and no service for the contaminated cart. The second notification is a non-collection notice on the cart, no service to the contaminated cart and a letter. The third notification is a non-collection notice, no service to the contaminated cart and a mailed letter with notification to the County of Los Angeles.

If Ware Disposal accidentally collects hazardous waste during collection, or there is a toxic spill or leak, the following is what Ware Disposal will accomplish in that specific event:

- Keep the area well ventilated;
- Extinguish any open flame or heat source, provided it is safe to do so;
- Keep all children and pets away;
- Ensure that employees wear gloves and protective clothing;
- Stop the product from spreading by covering the spill with an absorbent material;
- Provided that the material in question is relatively safe to handle, sweep and scoop the absorbent into a container with a lid or into a strong plastic bag. Clean area with soap and rags, put used rags into container as well. No Ware Disposal employee has ever been instructed to wash hazardous materials into the storm water system;
- The supervisor will label the container with the product name, chemical name and hazard category, provided that this information is readily available. If not, Ware Disposal will contact its hazardous waste collection provider to make a special pick up of said material and identify it accordingly.
- If the hazardous waste encountered is large and not manageable, the employee is to call the dispatch office immediately (all drivers are equipped with mobile phones with GPS systems), where the operations manager will contact the company's hazardous waste collection provider to make a special pick up, as well as contacting the County's Fire Department, Los Angeles County Health Care Agency, Environmental Health Division and the State of California Department of Health Services so that all appropriate governmental agencies have been contacted.

Ware Disposal Inc.

Lennox GDD

The appropriate local agencies will be notified either via telephonically, facsimile and/or e-mail, then include the incident on the next monthly report to the County of Los Angeles.

- If the hazardous waste is not detected during collection and ultimately ends up at Madison Materials, Madison has a hazardous waste screening program in place as well.

A. Protocol

Ware Disposal Inc. has developed and implemented the Un-Permitted Waste Screening Protocol included in the contract documentation in compliance with Applicable Law and including at a minimum:

1. Ongoing Employee Training in Identification

As a part of Ware Disposal Inc.'s ongoing training program, all drivers, swampers and route personnel are required to attend monthly and quarterly tailgate safety meetings. During these meetings we also conduct training sessions to educate employees on our safety policies, notification procedures, and household hazardous waste. Drivers are trained in both identification procedures and notification procedures when Un-Permitted waste is discovered. Drivers discovering Un-Permitted waste are instructed to complete a Non-Collection notice, place one copy on the container (whenever safe) and file the second copy at the office.

2. Driver Inspection

Based on our experience, the automated curbside collection process can hamper visual identification of Un-Permitted waste. For this reason, Ware Disposal Inc. has installed camera monitors on each automated vehicle. This additional step gives the driver/operator a clear visual of the contents of each container before it is commingled with the load.

3. Immediate Driver Response

While unloading the collection container into the holding hopper the driver has a clear view of the waste products as they are emptied and staged for compaction. All drivers are trained and prepared to segregate materials upon identification.

Un-Permitted materials such as U-Waste or Household Hazardous Waste or any suspicious unidentified materials shall be left at the service address and a Non-collection tag shall be affixed to the container.

Should any material appear to be dangerous in nature or a threat to the health and safety of the community or Ware Disposal Inc. personnel, the area route supervisor shall immediately notify the County fire department and the appropriate local agency for immediate resolution.

Ware Disposal Inc.

Lennox GDD

4. Driver Notification

All Ware Disposal Inc. drivers are trained and prepared to deal with any Un-Permitted waste issue. Ware Disposal Inc. personnel have been instructed to complete the non-collection tag and affix it to the offending container. The notification tag shall explain the violation and the proper means of disposal. All drivers are trained and prepared to segregate materials upon identification.

Each Un-Permitted disposal incident shall be reported to the dispatch center and the area route supervisor. The service address shall be monitored, if necessary, for additional disposal violations. Ware Disposal Inc. customer service shall log each incident and supply a copy to the County of Los Angeles.

Should any material appear to be dangerous in nature or a threat to the health and safety of the community or Ware Disposal Inc. personnel, the area route supervisor will immediately notify the County fire department and the appropriate local agency for immediate resolution.

5. Notification of Appropriate Agency or Department

Ware Disposal Inc. shall maintain a complaint and incident log for the Lennox GDD. Customer Service shall monitor and record all Un-Permitted waste violations/incidents identified by Ware Disposal Inc. personnel. All records shall be copied and supplied to the County of Los Angeles per the requirements of the contract. Ware Disposal Inc. shall report its observations to the Director in addition to notifying the offender. Habitual violators shall be reported to the County inspector and service may be suspended pending final resolution.

Should any material appear to be dangerous in nature or a threat to the health and safety of the community or Ware Disposal Inc. personnel, the area route supervisor will immediately notify the County fire department and the appropriate local agency for immediate resolution.

6. Appropriate Actions

Ware Disposal Inc. is committed to proper manifestation and management of Un-Permitted waste materials. In the event suspicious material is identified the area route supervisor will be immediately notified and proper containment materials will be applied. All collected materials will be properly containerized, removed, and transported by a license contractor in accordance with Applicable Law.

7. Compliance with Applicable Law

Ware Disposal Inc. will comply with all Local, State and Federal laws as outlined in on compliance standards defined in the Department of Transportation (DOT) (Title 49 CFR) and the United States Environmental Protection Agency Title 40 CFR, as well as with California EPA and DTSC regulations.

8. Form and Content of Labels

Each automated cart contains language and illustrations prohibiting customers from

Ware Disposal Inc.

Lennox GDD

discarding Un-Permitted Waste in English, Mandarin and Spanish. The final content of this information has been approved by the County of Los Angeles and was paid for and distributed by Ware Disposal Inc. or its contractor.

B. Prohibition on Collection

Unless licensed in accordance with Applicable Law, Ware Disposal Inc., is prohibited from collecting Un-Permitted waste, other than in connection with providing collection of bulky items, CEDS, or E-waste as outlined in the Lennox GDD contract. Ware Disposal Inc., will notify all persons required by Applicable Law of Unpermitted Wastes that it finds or observes in Solid Waste.

C. Reports to Director

Ware Disposal Inc. shall use Reasonable Business Efforts to report to the Director and the appropriate agency as required by Applicable Law any observance of suspicious materials it reasonably believes or suspects to contain Un-Permitted Waste being disposed of or released onto any County or any other public property, including storm drains, streets, or other public rights of way.

D. Labels

Ware Disposal Inc. shall affix labels to each automated cart used in the Lennox GDD and dumpster, with language and illustrations prohibiting customers from discarding Un-Permitted Waste in English, Mandarin and Spanish.

E. Safe Disposal Customer Education Program

As part of the Ware Disposal Inc. Un-Permitted Waste Screening Protocol, Ware Disposal Inc. has developed and implemented a customer education program to maximize exclusion of Un-Permitted Waste from disposal and promote safe handling of Un-Permitted Waste as stipulated in Part II Section 6. Ware Disposal Inc. shall distribute this education program in conjunction with its customer outreach for the Waste Diversion Program. Ware Disposal Inc. shall submit the materials to COUNTY at least one month prior to distributing them for the approval of format and content. Materials shall be developed and circulated once each calendar year in accordance with the terms and conditions outlined in Part II Section 6 of the Agreement.

Ware Disposal Inc. shall notify the subscribers regarding the safe handling of Un-Permitted Waste through our community outreach efforts. Unsafe disposal of Un-Permitted Waste will be strongly discouraged. Any items deemed to be hazardous waste, U-Waste, or E-Waste will not be collected in the regular cart collection program. Should such material be presented at the curb, a Non-Collection Notice will be affixed to the cart.

Lastly, Ware Disposal understands and agrees with the terms of the contract that pertain to unpermitted waste screening as described in Section 13

Ware Disposal Inc.

Lennox GDD

Exhibit 3D-Contractor Documentation

Item B.5 – ACKNOWLEDGMENT

This item consists of 4 pages (including this page).

B.5 ACKNOWLEDGMENT

Ware Disposal Inc., acknowledges that it has read and completely understands the program(s) related to the Safely Surrendered Baby Law as articulated in the bid documents and the County of Los Angeles website www.babysafela.org.

Ware Disposal Inc., agrees to provide each employee involved with the contract a copy of the "No Shame. No Blame. No Names." County program documentation, in both English and Spanish, as provided in the downloadable version on the County of Los Angeles website.

Ware Disposal Inc., and its contractors will post posters of copies of County of Los Angeles posters regarding the Safely Surrendered Baby Law in every facility where their employees are present.

And Ware Disposal Inc., acknowledges receipt of fact sheet relating to the Non-Employee Injury Report form.



Signature

COUNTY OF LOS ANGELES
NON-EMPLOYEE INJURY REPORT

Dept Name _____ Dept # _____
DIV. or Facility _____
SECTION _____
IRMIS Code # _____

Prepared for County Counsel in defense of the County Special Districts and employees

INSTRUCTIONS:

- 1 All incidents involving injury to non-employees, however, minor, while on County property (owned or leased) must be reported, by the Guard, Marshal's Office or Department in proximity to incident, as follows:

Two copies to: CARL WARREN & CO., P.O. Box 116, Glendale, CA 91209-0116

FATALITIES OR SERIOUS INJURIES MUST BE REPORTED IMMEDIATELY BY PHONE TO CARL WARREN & CO. (818) 247-2206

INJURED NON-EMPLOYEE:

- 1 Name _____
(Last Name) (First Name) (Middle Name)
 - 2 Address _____
 - 3 Age _____
 - 4. Sex Male Female
- If minor, give name of parent or guardian _____

TIME AND PLACE:

- 5 Place of occurrence _____
(Name of County Facility, Bldg. Street Number) (City or Town)
 - 6. Location in building _____
(In detail: Bldg., Floor, Room No.)
 - 7 Date of occurrence _____ Hour _____ AM/PM
 - 8. Weather: _____ Clear _____ Rain
- POLICE REPORT Yes No POLICE AGENCY REPORTING _____ STATION _____ DEPT #, _____

DESCRIPTION OF INCIDENT:

- 9. What was employee doing? _____
- 10. What happened? (Describe fully, stating whether injured person fell, was struck, etc.) Give all factors contributing to injury:

(If necessary, continue on separate sheet)
- 11 Condition of floor, sidewalk, steps or other physical property or equipment involved: _____
- 12. Was there any defect or foreign substance or object involved? If so, describe: _____
- 13. If slip and fall. Person's shoes _____ heels _____ caps _____
(Type) (Type) (Type)

NATURE OF INJURY AND PART OF BODY AFFECTED:

- 14 Be specific! State which part of body injured; whether right or left, etc. If exact nature of injury is undetermined, give opinion:

TREATMENT GIVEN:

- 15. Was treatment given to the injured person by County Personnel? _____ By whom? _____
 Type of Treatment _____
- 16. Was ambulance called? _____ Which company _____ By whom? _____
- 17. Taken to hospital? _____ Which? _____

STATEMENTS BY INJURED AND WITNESSES:

(Note. Attach additional pages if needed)

18. Statement of injured as to what happened. _____

19. Witness No. 1: Name: _____
(Last Name) (First Name) (Initial)
 Address: _____ Telephone: _____
(Number) (Street) (City)
 Statement: _____

20. Witness No. 2: Name: _____
(Last Name) (First Name) (Initial)
 Address: _____ Telephone: _____
(Number) (Street) (City)
 Statement: _____

Date Report Prepared: _____
 Prepared by: _____ Phone: _____
(Print Name)
 _____ Dept. _____
(Title)

(Signature)

Exhibit 3D-Contractor Documentation

Item B.6 – INSURANCE AND PERFORMANCE ASSURANCE

This item consists of 25 pages (including this page).

LENNOX GDD INSURANCE CERTIFICATE



CERTIFICATE OF LIABILITY INSURANCE

DATE (MM/DD/YYYY)
6/14/2018

THIS CERTIFICATE IS ISSUED AS A MATTER OF INFORMATION ONLY AND CONFERS NO RIGHTS UPON THE CERTIFICATE HOLDER. THIS CERTIFICATE DOES NOT AFFIRMATIVELY OR NEGATIVELY AMEND, EXTEND OR ALTER THE COVERAGE AFFORDED BY THE POLICIES BELOW. THIS CERTIFICATE OF INSURANCE DOES NOT CONSTITUTE A CONTRACT BETWEEN THE ISSUING INSURER(S), AUTHORIZED REPRESENTATIVE OR PRODUCER, AND THE CERTIFICATE HOLDER.

IMPORTANT: If the certificate holder is an ADDITIONAL INSURED, the policy(ies) must be endorsed. If SUBROGATION IS WAIVED, subject to the terms and conditions of the policy, certain policies may require an endorsement. A statement on this certificate does not confer rights to the certificate holder in lieu of such endorsement(s).

PRODUCER HUB International Insurance Services Inc. License #0757776 3636 American River Drive, Suite 200 Sacramento CA 95864		CONTACT NAME: Rocio Leon PHONE (A/C, No, Ext): 916-480-4134 E-MAIL ADDRESS: Rocio.Leon@hubinternational.com FAX (A/C, No): 916-993-7234	
INSURED Ware D sposal Inc P O Box 1318 Santa Ana CA 92702		INSURER(S) AFFORDING COVERAGE	
WAREDIS-02		INSURER A: Greenwich Insurance Company (A)	NAIC # 22322
		INSURER B: Westchester Surplus Lines Insurance Company (A)	10172
		INSURER C: Alaska National Insurance Company (A)	38733
		INSURER D: Evanston Insurance Company (A)	35378
		INSURER E:	
		INSURER F:	

COVERAGES CERTIFICATE NUMBER: 494008170 REVISION NUMBER:

THIS IS TO CERTIFY THAT THE POLICIES OF INSURANCE LISTED BELOW HAVE BEEN ISSUED TO THE INSURED NAMED ABOVE FOR THE POLICY PERIOD INDICATED. NOTWITHSTANDING ANY REQUIREMENT, TERM OR CONDITION OF ANY CONTRACT OR OTHER DOCUMENT WITH RESPECT TO WHICH THIS CERTIFICATE MAY BE ISSUED OR MAY PERTAIN, THE INSURANCE AFFORDED BY THE POLICIES DESCRIBED HEREIN IS SUBJECT TO ALL THE TERMS, EXCLUSIONS AND CONDITIONS OF SUCH POLICIES. LIMITS SHOWN MAY HAVE BEEN REDUCED BY PAID CLAIMS

INSR LTR	TYPE OF INSURANCE	ADDL SUBR INSD WVD	POLICY NUMBER	POLICY EFF (MM/DD/YYYY)	POLICY EXP (MM/DD/YYYY)	LIMITS
A X	COMMERCIAL GENERAL LIABILITY CLAIMS-MADE X OCCUR \$1,000 PD Ded Per Occurrence GEN'L AGGREGATE LIMIT APPLIES PER: POLICY X PROJ LOC OTHER	Y Y	GEC300730-03	2/28/2018	2/28/2019	EACH OCCURRENCE \$1,000,000 DAMAGE TO RENTED PREMISES (Ea occurrence) \$100,000 MED EXP (Any one person) \$5,000 PERSONAL & ADV INJURY \$1,000,000 GENERAL AGGREGATE \$2,000,000 PRODUCTS - COM/PROP AGG \$2,000,000
B X	AUTOMOBILE LIABILITY ANY AUTO ALL OWNED AUTOS SCHEDULED AUTOS H-RED AUTOS NON-OWNED AUTOS	Y Y	AEC304538603	2/28/2018	2/28/2019	COMBINED SINGLE LIMIT (Ea accident) \$1,000,000 BODILY INJURY (Per person) \$ BODILY INJURY (Per accident) \$ PROPERTY DAMAGE (Per accident) \$ BI/PD Deductible \$5,000
B X	UMBRELLA LIAB X OCCUR EXCESS LIAB CLAIMS-MADE DED RETENTION		G48863306031	2/1/2018	2/28/2019	EACH OCCURRENCE \$10,000,000 AGGREGATE \$10,000,000
C	WORKERS COMPENSATION AND EMPLOYERS' LIABILITY ANY PROPRIETOR/PARTNER/EXECUTIVE OFFICER/ MEMBER EXCLUDED? (Mandatory in NH) If yes, describe under DESCRIPTION OF OPERATIONS below	Y/N N/A	17H WS 05450	8/1/2017	8/1/2018	X PER STATUTE E.L. EACH ACCIDENT \$1,000,000 E.L. DISEASE - EA EMPLOYEE \$1,000,000 E.L. DISEASE - POLICY LIMIT \$1,000,000
D	Contractors Pollution Liability/ Transportation Pollution Liability		17CPLOWE00598	2/28/2017	2/28/2020	Each Poll Condition 2,000,000 Aggregate 4,000,000 Deductible 10,000

DESCRIPTION OF OPERATIONS / LOCATIONS / VEHICLES (ACORD 101, Additional Remarks Schedule, may be attached if more space is required)
 General Liability Per Project Aggregate Applies per written contract
 Re: Lennox Garbage Disposal District
 Additional Insured County of Los Angeles and its Special Districts, elected officials, officers, agents, and employees as additional insured with respect to liability arising out of ongoing and completed operations as required per written contract.
 CA0444 1013 CG2010 0413, CG2037 0413, CG2404 0509, IXI405 0910, MEIL1203 0312, MEEI2205 1214, MEEI2209 0516 WC040306 0484, XIL424 0605

CERTIFICATE HOLDER County of Los Angeles Department of Public Works Business Relations and Contracts Division, 8th Flo Attn: David Pang 900 S Fremont Avenue Alhambra CA 91803	CANCELLATION SHOULD ANY OF THE ABOVE DESCRIBED POLICIES BE CANCELLED BEFORE THE EXPIRATION DATE THEREOF, NOTICE WILL BE DELIVERED IN ACCORDANCE WITH THE POLICY PROVISIONS. AUTHORIZED REPRESENTATIVE
---	--

POLICY NUMBER AEC004538603

COMMERCIAL AUTO
CA 04 44 10 13

THIS ENDORSEMENT CHANGES THE POLICY. PLEASE READ IT CAREFULLY.

WAIVER OF TRANSFER OF RIGHTS OF RECOVERY AGAINST OTHERS TO US (WAIVER OF SUBROGATION)

This endorsement modifies insurance provided under the following:

- AUTO DEALERS COVERAGE FORM
- BUSINESS AUTO COVERAGE FORM
- MOTOR CARRIER COVERAGE FORM

With respect to coverage provided by this endorsement, the provisions of the Coverage Form apply unless modified by the endorsement

This endorsement changes the policy effective on the inception date of the policy unless another date is indicated below

Named Insured: WARE DISPOSAL, INC
Endorsement Effective Date: February 28 2018

SCHEDULE

<p>Name(s) Of Person(s) Or Organization(s):</p> <p>ANY PERSON OR ORGANIZATION THAT YOU ARE REQUIRED IN A WRITTEN CONTRACT OR WRIT TEN AGREEMENT TO WAIVE ANY RIGHT OF RECOVERY WE MAY HAVE AGAINST THE PERSON OR ORGANIZATION, PROVIDED THE "BODILY INJURY" OR "PROPERTY DAMAGE," OCCURS SUBSEQUENT TO THE EXECUTION OF THE WRITTEN CONTRACT OR WRITTEN AGREEMENT.</p>
<p>Information required to complete this Schedule, if not shown above, will be shown in the Declarations</p>

The Transfer Of Rights Of Recovery Against Others To Us condition does not apply to the person(s) or organization(s) shown in the Schedule, but only to the extent that subrogation is waived prior to the "accident" or the "loss" under a contract with that person or organization

POLICY NUMBER GEC380073003

COMMERCIAL GENERAL LIABILITY
CG 20 10 04 13

THIS ENDORSEMENT CHANGES THE POLICY. PLEASE READ IT CAREFULLY.

**ADDITIONAL INSURED – OWNERS, LESSEES OR
CONTRACTORS – SCHEDULED PERSON OR
ORGANIZATION**

This endorsement modifies insurance provided under the following

COMMERCIAL GENERAL LIABILITY COVERAGE PART

SCHEDULE

Name Of Additional Insured Person(s) Or Organization(s)	Location(s) Of Covered Operations
ANY PERSON OR ORGANIZATION THAT YOU ARE REQUIRED IN A WRITTEN CONTRACT OR WRITTEN AGREEMENT TO INCLUDE AS AN ADDITIONAL INSURED, PROVIDED THE "BODILY INJURY" OR "PROPERTY DAMAGE" OCCURS SUBSEQUENT TO THE EXECUTION OF THE WRITTEN CONTRACT OR WRITTEN AGREEMENT.	VARIOUS
Information required to complete this Schedule, if not shown above, will be shown in the Declarations	

A. Section II – Who Is An Insured is amended to include as an additional insured the person(s) or organization(s) shown in the Schedule, but only with respect to liability for "bodily injury", "property damage" or "personal and advertising injury" caused, in whole or in part, by

1. Your acts or omissions; or
2. The acts or omissions of those acting on your behalf,

in the performance of your ongoing operations for the additional insured(s) at the location(s) designated above

However:

1. The insurance afforded to such additional insured only applies to the extent permitted by law, and
2. If coverage provided to the additional insured is required by a contract or agreement, the insurance afforded to such additional insured will not be broader than that which you are required by the contract or agreement to provide for such additional insured

B. With respect to the insurance afforded to these additional insureds the following additional exclusions apply.

This insurance does not apply to "bodily injury" or "property damage" occurring after:

1. All work, including materials, parts or equipment furnished in connection with such work, on the project (other than service, maintenance or repairs) to be performed by or on behalf of the additional insured(s) at the location of the covered operations has been completed, or
2. That portion of "your work" out of which the injury or damage arises has been put to its intended use by any person or organization other than another contractor or subcontractor engaged in performing operations for a principal as a part of the same project

- C. With respect to the insurance afforded to these additional insureds, the following is added to **Section III – Limits Of Insurance:**

If coverage provided to the additional insured is required by a contract or agreement, the most we will pay on behalf of the additional insured is the amount of insurance:

1. Required by the contract or agreement; or
 2. Available under the applicable Limits of Insurance shown in the Declarations;
- whichever is less

This endorsement shall not increase the applicable Limits of Insurance shown in the Declarations.

POLICY NUMBER GEC300073003

COMMERCIAL GENERAL LIABILITY
CG 20 37 04 13

THIS ENDORSEMENT CHANGES THE POLICY. PLEASE READ IT CAREFULLY.

ADDITIONAL INSURED – OWNERS, LESSEES OR CONTRACTORS – COMPLETED OPERATIONS

This endorsement modifies insurance provided under the following

COMMERCIAL GENERAL LIABILITY COVERAGE PART
PRODUCTS/COMPLETED OPERATIONS LIABILITY COVERAGE PART

SCHEDULE

Name Of Additional Insured Person(s) Or Organization(s)	Location And Description Of Completed Operations
<p>ANY PERSON OR ORGANIZATION THAT YOU ARE REQUIRED IN A WRITTEN CONTRACT OR WRITTEN AGREEMENT TO INCLUDE AS AN ADDITIONAL INSURED. PROVIDED THE "BODILY INJURY" OR "PROPERTY DAMAGE" OCCURS SUBSEQUENT TO THE EXECUTION OF THE WRITTEN CONTRACT OR WRITTEN AGREEMENT</p>	<p>VARIOUS</p>
<p>Information required to complete this Schedule, if not shown above, will be shown in the Declarations</p>	

A. Section II - Who Is An Insured is amended to include as an additional insured the person(s) or organization(s) shown in the Schedule, but only with respect to liability for "bodily injury" or "property damage" caused, in whole or in part, by "your work" at the location designated and described in the Schedule of this endorsement performed for that additional insured and included in the "products-completed operations hazard"

However:

1. The insurance afforded to such additional insured only applies to the extent permitted by law, and
2. If coverage provided to the additional insured is required by a contract or agreement, the insurance afforded to such additional insured will not be broader than that which you are required by the contract or agreement to provide for such additional insured

B. With respect to the insurance afforded to these additional insureds, the following is added to Section III - Limits Of Insurance:

If coverage provided to the additional insured is required by a contract or agreement, the most we will pay on behalf of the additional insured is the amount of insurance:

1. Required by the contract or agreement, or
2. Available under the applicable Limits of Insurance shown in the Declarations,

whichever is less

This endorsement shall not increase the applicable Limits of Insurance shown in the Declarations

ENDORSEMENT #

This endorsement, effective 12:01 a.m., 02/28/2018 forms a part of
Policy No. AEC004538603 issued to Ware Disposal, Inc.
by Greenwich Insurance Company

THIS ENDORSEMENT CHANGES THE POLICY. PLEASE READ IT CAREFULLY.

CANCELLATION NOTIFICATION TO OTHERS ENDORSEMENT

In the event coverage is cancelled for any statutorily permitted reason, other than nonpayment of premium, advanced written notice will be mailed or delivered to person(s) or entity(ies) according to the notification schedule shown below:

Name of Person(s) or Entity(ies)	Mailing Address	Number of Days Advanced Notice of Cancellation
County of Los Angeles Department of Public Works	Business Relations and Contracts Division, 8 th Floor Attn: David Pang 900 S. Fremont Avenue Alhambra, CA 91803	30

All other terms and conditions of the Policy remain unchanged

IXI 405 0910

© 2010 X L America, Inc. All Rights Reserved
May not be copied without permission

ENDORSEMENT #

This endorsement, effective 12:01 a.m., 02/28/2018 forms a part of
Policy No. GEC300073003 issued to Ware Disposal, Inc
by Greenwich Insurance Company

THIS ENDORSEMENT CHANGES THE POLICY. PLEASE READ IT CAREFULLY

CANCELLATION NOTIFICATION TO OTHERS ENDORSEMENT

In the event coverage is cancelled for any statutorily permitted reason, other than nonpayment of premium, advanced written notice will be mailed or delivered to person(s) or entity(ies) according to the notification schedule shown below.

Name of Person(s) or Entity(ies)	Mailing Address:	Number of Days Advanced Notice of Cancellation
County of Los Angeles Department of Public Works	Business Relations and Contracts Division, 8 th Floor Attn David Pang 900 S. Fremont Avenue Alhambra, CA 91803	30

All other terms and conditions of the Policy remain unchanged.

IXI 405 0910

© 2010 X L America, Inc. All Rights Reserved.
May not be copied without permission



WAIVER OF OUR RIGHT TO RECOVER FROM OTHERS ENDORSEMENT - CALIFORNIA

We have the right to recover our payments from anyone liable for an injury covered by this policy. We will not enforce our right against the person or organization named in the Schedule. (This agreement applies only to the extent that you perform work under a written contract that requires you to obtain this agreement from us.)

You must maintain payroll records accurately segregating the remuneration of your employees while engaged in the work described in the Schedule.

The additional premium for this endorsement shall be 2 % of the California workers' compensation premium otherwise due on such remuneration.

Person or Organization	SCHEDULE	Job Description
Blanket Waiver. Any person or organization for whom the insured, has agreed by written contract to furnish this waiver.		

This endorsement changes the policy to which it is attached and, unless otherwise stated, is effective on the date issued at 12:01 A.M. standard time at your mailing address shown in the policy. The information below is required only when this endorsement is issued subsequent to commencement of the policy.

Endorsement Effective August 1st, 2017

Policy No. 17H WS 05450

Insured Ware Disposal, Inc

Endorsement No. 4

Countersigned By Wayne Bryan

John O. Bronson Co. / Sacramento

WC 04 03 06 (04 84)

ENDORSEMENT #

This endorsement, effective 12:01 a.m., 02-28-2018, forms a part of
Policy No. GEC3000730-03 issued to Ware Disposal, Inc.
by Greenwich Insurance Company.

THIS ENDORSEMENT CHANGES THE POLICY. PLEASE READ IT CAREFULLY.

PRIMARY INSURANCE CLAUSE ENDORSEMENT

This endorsement modifies insurance provided under the following:

COMMERCIAL GENERAL LIABILITY COVERAGE PART
PRODUCTS/COMPLETED OPERATIONS COVERAGE PART

It is agreed that to the extent that insurance is afforded to any Additional Insured under this policy, this insurance shall apply as primary and not contributing with any insurance carried by such Additional Insured, as required by written contract.

All other terms and conditions of this policy remain unchanged.

XIL 424 0605
©. 2005 XL America, Inc.



THIS ENDORSEMENT CHANGES THE POLICY. PLEASE READ IT CAREFULLY.

INTERLINE

POLICY CHANGES

CHANGE NUMBER: 6

POLICY NUMBER: 17CPLOWE00598	POLICY CHANGES EFFECTIVE 06/13/2018	COMPANY: EVANSTON INSURANCE COMPANY
NAMED INSURED WARE DISPOSAL, INC. P.O. BOX 1318 SANTA ANA, CA 92702	AUTHORIZED REPRESENTATIVE 13500 Worldwide Facilities, LLC 725 S. Figueroa Street, 19 th Floor Los Angeles, CA 90017	
COVERAGE PART(S) AFFECTED: CONTRACTOR'S POLLUTION LIABILITY COVERAGE FORM		

The following item(s):

<input type="checkbox"/> Insured's Name/Additional Named Insureds	<input type="checkbox"/> Insured's Mailing Address	<input type="checkbox"/> Policy Number
<input type="checkbox"/> Effective/Expiration Date/Policy Period	<input type="checkbox"/> Company	<input type="checkbox"/> Locations/Location Description
<input type="checkbox"/> Insured's Legal Status/Business Description	<input type="checkbox"/> Minimum Earned Premium	<input type="checkbox"/> Rates
<input checked="" type="checkbox"/> Coverage Forms and Endorsements	<input type="checkbox"/> Policy Cancel/Reinstatement	<input type="checkbox"/> Limits/Exposures/Premium Basis
<input type="checkbox"/> Additional Insureds, Loss Payees, Mortgagees	<input type="checkbox"/> Buildings/Personal Property	<input type="checkbox"/> Deductibles
<input type="checkbox"/> Aggregate Cap	<input type="checkbox"/> Classification/Class Codes	<input type="checkbox"/> Underlying Insurance Information
<input type="checkbox"/> Per Vehicle Limit	<input type="checkbox"/> Vehicle	<input type="checkbox"/> Drivers
<input type="checkbox"/> Vehicle Description (Type/Year/Make/Model/ Vehicle Identification Number/Cost New/Value)	<input type="checkbox"/> Equipment	<input type="checkbox"/> Other (describe below)

is (are) changed added deleted as shown below:

1. Endorsement # 5 is hereby declared null and void and deleted in its entirety from this policy.
2. Form MEEI 2205 12 14 (Amendment Of Limits Of Insurance (Designated Project Or Premises)) is added to this policy as attached.
3. Form MEEI 2209 05 16 (Primary And Non-Contributory With Waiver Of Subrogation For Specified Project Or Contract) is added to this policy as attached

The above amendments result in a change in the premium as follows

<input checked="" type="checkbox"/>	NO CHANGES	<input type="checkbox"/>	TO BE ADJUSTED AT AUDIT	<input type="checkbox"/>	ADDITIONAL PREMIUM \$	<input type="checkbox"/>	RETURN PREMIUM \$
<input type="checkbox"/>	NO RETURN PREMIUM - CLAIM STILL IN PROCESS	<input type="checkbox"/>	NO RETURN PREMIUM - TOTAL LOSS TO INSURED ITEM	<input type="checkbox"/>	NO RETURN PREMIUM - FULLY EARNED PROVISION APPLIES	<input type="checkbox"/>	OTHER (DESCRIBE):

All other terms and conditions remain unchanged

A handwritten signature in cursive script, appearing to read "T. W. Shaw", written in dark ink on a light background.

AUTHORIZED SIGNATURE



ENVIRONMENTAL
POLICY NUMBER: 17CPLOWE00598

EVANSTON INSURANCE COMPANY

THIS ENDORSEMENT CHANGES THE POLICY. PLEASE READ IT CAREFULLY.

**AMENDMENT OF LIMITS OF INSURANCE
(DESIGNATED PROJECT OR PREMISES)**

This endorsement modifies insurance provided under the following, where indicated by an "X" below:

- COMMERCIAL GENERAL LIABILITY COVERAGE FORM
- CONTRACTOR'S POLLUTION LIABILITY COVERAGE FORM
- ENVIRO FLEX ENVIRONMENTAL IMPAIRMENT LIABILITY COVERAGE FORM
- ENVIRONMENTAL PROFESSIONAL LIABILITY COVERAGE FORM
- OWNERS AND CONTRACTORS PROTECTIVE LIABILITY COVERAGE FORM

SCHEDULE

DESIGNATED PREMISES: Various premises located within the Lennox Garbage Disposal District in the County of Los Angeles, California

DESIGNATED PROJECT: The collection, transportation, delivery, storage, processing, recycling, composting and disposal of solid wastes for premises located within the Lennox Garbage Disposal District in the County of Los Angeles, California, as stipulated in the Exclusive Franchise Agreement between the County of Los Angeles and Ware Disposal, Inc.

The Limits of Insurance shown in this Schedule are:

- Included within and not in addition to the Limits of Insurance in the Declarations
- In addition to the Limits of Insurance in the Declarations.

	Limits Of Insurance	Retroactive Date
<u>COMMERCIAL GENERAL LIABILITY</u>		
General Aggregate Limit	\$	
Products-Completed Operations Limit Aggregate Limit	\$	
Personal And Advertising Injury Limit	\$	
Each Occurrence Limit	\$	
Damage To Premises Rented To You Limit	\$	
Medical Expense Limit	\$	
<u>CONTRACTOR'S POLLUTION LIABILITY</u>		
Each Pollution Condition Limit	\$ 2,000,000	Not Applicable
General Aggregate Limit	\$ 4,000,000	
<u>ENVIRONMENTAL PROFESSIONAL LIABILITY</u>		
Each Claim Limit	\$	
General Aggregate Limit	\$	
<u>ENVIRO FLEX ENVIRONMENTAL IMPAIRMENT LIABILITY</u>		
Each Loss Limit	\$	
Each Coverage Aggregate Limit	\$	

MEEI 2205 12 14

Includes copyrighted material of Insurance Services Office, Inc., with its permission

Coverage Form Aggregate Limit	\$
<u>COMBINED POLICY AGGREGATE LIMIT OF LIABILITY</u>	\$ 5,000,000

- A. The limits of insurance shown in the Declarations are replaced by the limits designated in the Schedule above as respects the designated project or premises shown above.
- B. The Retroactive Date(s) shown in the Declarations are replaced by the Retroactive Date(s) designated in the Schedule above, but only as respects coverages for which an entry is shown in the above Schedule.

All other terms and conditions remain unchanged



ENVIRONMENTAL
POLICY NUMBER: 17CPLOWL00598

EVANSTON INSURANCE COMPANY

THIS ENDORSEMENT CHANGES THE POLICY. PLEASE READ IT CAREFULLY.

PRIMARY AND NON-CONTRIBUTORY WITH WAIVER OF SUBROGATION FOR SPECIFIED PROJECT OR CONTRACT

This endorsement modifies insurance provided under the following, where indicated by an "X" in the checkbox(es) below

- COMMERCIAL GENERAL LIABILITY COVERAGE FORM
- CONTRACTOR'S POLLUTION LIABILITY COVERAGE FORM
- PRODUCTS/COMPLETED OPERATIONS LIABILITY COVERAGE FORM

SCHEDULE

Project Name:	Exclusive Franchise Contract between the County of Los Angeles and Ware Disposal, Inc. for the collection, transportation, delivery, storage, processing, recycling, composting and disposal of solid wastes for premises located within the Lennox Garbage Disposal District in the County of Los Angeles, California
Location:	Various premises located within the Lennox Garbage Disposal District in the County of Los Angeles, California
Operations / Work / Services:	The collection, transportation, delivery, storage, processing, recycling, composting and disposal of solid wastes
Contract # / Work Order / ID #:	Exclusive Franchise Contract between the County of Los Angeles and Ware Disposal, Inc.
Name Of Person Or Organization:	County of Los Angeles Department of Public Works Business Relations and Contracts Division Attn: David Pang 900 S. Fremont Avenue, 8 th Floor Alhambra, CA 91803

Please refer to each Coverage Form to determine which terms are defined. Words shown in quotations on this endorsement may or may not be defined in all Coverage Forms.

The following changes apply only with respect to the Project shown in the Schedule of this endorsement:

- A. The Other Insurance condition of the Coverage Form(s) indicated above is replaced by the following:

Other Insurance

This insurance will be primary and not contributory with any other insurance available to the person or organization shown in the Schedule of this endorsement under any other third party liability policy

- B. The Transfer Of Rights Of Recovery Against Others To Us condition is replaced by the following:

Transfer Of Rights Of Recovery Against Others To Us

We waive any right of recovery we may have against the person or organization shown in the Schedule of this endorsement because of payments we make for injury or damage arising out of your ongoing operations or "your work" done under a written contract with that person or organization and included in the "products-completed operations hazard" or "completed operations". This waiver applies only to the person or organization shown in the

Schedule of this endorsement. This waiver shall not apply for "occurrences" or "pollution conditions" resulting from the sole negligence of the person or organization shown in the Schedule above.

The coverage provided by Paragraphs A. and B. above applies only if:

1. The person or organization shown in the Schedule of this endorsement is also granted additional insured status under this insurance; and
2. Required by a written contract, signed by both parties and executed prior to the commencement of operations.

All other terms and conditions remain unchanged



ENVIRONMENTAL
POLICY NUMBER 17CPLOWE00598

EVANSTON INSURANCE COMPANY

THIS ENDORSEMENT CHANGES THE POLICY. PLEASE READ IT CAREFULLY.

TRANSPORTATION POLLUTION LIABILITY (FIRST AND THIRD PARTY VEHICLES)

This endorsement modifies insurance provided under the following:

CONTRACTOR'S POLLUTION LIABILITY COVERAGE FORM

SCHEDULE

SUBLIMITS

- Each Claim \$ Not Applicable
- Each Pollution Condition \$ 1,000,000
- Total All Claims \$ 1,000,000

DEDUCTIBLES

- Each Claim \$ Not Applicable
- Each Pollution Condition \$ SEE MEEI 2226 02 18

RETROACTIVE DATE: Not Applicable

SCHEDULE OF COVERED AUTOS

<u>Vehicle #:</u>	<u>Year:</u>	<u>Make:</u>	<u>Model:</u>	<u>Identification Number:</u>	<u>Sublimit</u>	<u>Deductible</u>
					\$	\$
					\$	\$
					\$	\$
					\$	\$
					\$	\$
					\$	\$
					\$	\$
					\$	\$
					\$	\$
					\$	\$

A. SECTION I - COVERAGES, paragraph 2. Exclusions. n. Transported Materials is replaced by the following

n. Transported Materials

'Bodily injury' or 'property damage' arising from any waste or products or materials transported, shipped, or delivered by aircraft, auto, or watercraft, to a location beyond the boundaries of a jobsite at which you are performing or have performed 'your work'. However, this exclusion does not apply to 'bodily injury' or 'property damage' arising from any waste or any products or materials transported, shipped, or delivered either by

- (1) You in a 'covered auto', or
- (2) On your behalf by a 'carrier'

B. The following is added to the applicable DEFINITIONS section of the Coverage Form to which this endorsement is attached

'Covered auto' means "autos" owned and operated by you, but only those that are listed on the above Schedule, however, if no 'autos' are listed on the above Schedule, all 'autos' owned and operated by you will be 'covered autos'

C. The coverage provided by this endorsement is subject to the sublimits shown in the above Schedule, which are the most we will pay for:

1. Each "claim",
2. Each "pollution condition", and
3. The total of all "claims" if applicable.

Sublimits shown for vehicles in the Schedule Of Covered Autos are the most we will pay for either each 'claim' or each 'pollution condition' for each scheduled vehicle.

If no sublimits are indicated in the above Schedule, then the Limits of Insurance shown in the Declarations will apply.

- D. We will pay covered 'claims' in excess of the Each Claim Deductible or the Each Pollution Condition Deductible, if a Deductible amount for such is shown in the above Schedule.
- E. The sublimits shown in the above Schedule are included within, and are not in addition to, the Limits of Insurance shown on the Declarations.
- F. Coverage provided by this endorsement shall not be utilized to evidence financial responsibility of any insured under any applicable federal, state, provincial or local law.
- G. The Retroactive Date shown in the Declarations, if any, is replaced by the Retroactive Date shown in the Schedule above, but only as respects coverage provided by this endorsement.

All other terms and conditions remain unchanged.

LENNOX GDD PERFORMANCE BOND



JUN 21 2018

Inland Surety

A Division of HUB International Insurance Services Inc.

3390 University Avenue, Suite 330
Riverside, CA 92504
(951) 788-8581
Fax: (951) 742-4791
E.L. No. 0757776

June 18, 2018

Ware Disposal, Inc.
Attention: Jay Ware
1035 East 4th Street
Santa Ana, CA 92701

RE DESCRIPTION: 100% Performance Bond
TRANSACTION: New
SURETY: RLI Insurance Company
BOND NUMBER: CMS0288990
EFFECTIVE DATE: 08/13/2018
EXPIRATION DATE: 06/30/2019

This bond is continuous until cancelled. If applicable, payment is due upon receipt of our invoice. Non-payment will result in cancellation.

This bond is non-cancelable and continues indefinitely. If the bond is no longer required, please provide us with applicable documentation. The premium is due until the evidence of release or satisfaction is accepted by the surety.

This is a term bond and will not renew at expiration.

PRINCIPAL: Ware Disposal, Inc.
OBLIGEE: County of Los Angeles, Department of Public Works
Business Relations and Contracts Division, 8th Floor
Attention: David Pang
900 S. Fremont Avenue
Alhambra, CA 91803

RE Lennox Garbage Disposal District

BOND AMOUNT \$208,089.15
PREMIUM \$3,212.00 TERM: 1 Year(s)

X Enclosed is ONE (1) ORIGINAL Bond(s) or RIDER(s) and a YOUR COPY. X As applicable, please sign and file the ORIGINAL(s) with the OBLIGEE.

Enclosed is a YOUR COPY only. The ORIGINAL(s) has been filed directly with the OBLIGEE.

- Our invoice will follow shortly.
- Comments.

Please let us know if you have any questions. Thank you!

ISSUED IN ONE ORIGINAL COUNTERPART

BOND NO. CMS0288990
PREMIUM \$3,121.00

ORIGINAL

BOND FOR FAITHFUL PERFORMANCE
Annually Renewable Performance and Payment Bond

KNOW ALL MEN BY THESE PRESENTS, That Ware Disposal, Inc.

("Principal") and RLI Insurance Company ("Surety") are held and firmly bound unto the COUNTY OF LOS ANGELES, State of California ("Obligee"), in the penal sum of Two Hundred Eight Thousand Eighty Nine and 15/100's (\$208,089.15) dollars for the payment of which sum, the Principal and Surety bind themselves, and each of their heirs, administrators, executors, successors and assigns, jointly and severally, firmly by these presents.

WHEREAS, the Principal has entered into a contract with the Obligee entitled (The) Lennox Garbage Disposal District (the "Franchise Agreement") for the performance of the terms, conditions, covenants and obligations and services set forth in the Franchise Agreement, including but not limited to providing Franchise services in bins or dumpsters and roll off boxes in the unincorporated areas of Los Angeles County and payment of the applicable franchise fee, and payment of any liquidated damages assessed pursuant to the Franchise Agreement, and

WHEREAS, the Franchise Agreement is hereby referred to and made a part hereof as fully and to the same extent as if copied at length herein,

NOW, THEREFORE, THE CONDITION OF THE ABOVE OBLIGATION IS SUCH, that if the Principal shall well and truly perform each and every covenant and obligation in the Franchise Agreement at the time and in the manner specified in the Franchise Agreement during the term of this bond, and shall reimburse the Obligee for all loss and damage which the Obligee may sustain by reason of failure or default on the part of the Principal, then this obligation shall be void, otherwise it shall remain in full force and effect.

PROVIDED, however that this bond is subject to the following conditions and provisions:

1. This bond is for the term beginning August 13, 2018 and ending June 30, 2019
2. In the event of default by the Principal in the performance of the Franchise Agreement during the term of this bond, the Surety shall be liable only for the loss to the Obligee due to damages as described in Section 15 of the Franchise Agreement. The Surety, after investigation, shall with reasonable promptness determine the amount for which it may be liable to the Obligee as soon as practicable after the amount is determined and tender payments to the Obligee to secure substitute services, remedy damages incurred, and ensure satisfaction of all performance obligations as set forth in Section 15 of the Franchise Agreement and only for the purpose of enforcing such Franchise Agreement obligations as they pertain to this bond.
3. Except for a claim for compensatory damages as defined in Section 17, D.1 of the Franchise Agreement, no claim, action, suit or proceeding, except as hereinafter set forth, shall be had or maintained against the Surety on this instrument unless it be brought or instituted and process served upon the Surety within two years after the expiration of the stated terms of this bond.
4. Neither non-renewal by the Surety, nor the failure or inability of the Principal to file a replacement bond in the event of non-renewal, shall itself constitute loss by the Obligee recoverable under this bond, notwithstanding any language in the Franchise Agreement to the contrary.
5. The bond may be extended for additional one year terms at the option of the Surety by Continuation Certificate executed by the Surety.
6. The liability of the Surety under this bond and all Continuation Certificates shall not be cumulative and under no circumstances shall the Surety's liability exceed the penal sum stated herein.
7. No right of action shall accrue on this bond to or for the use of any person, entity or corporation other than the Obligee and this bond cannot be assigned to any other party without the written consent of the Surety.
8. Other than the Surety's right to renew this bond to extend its termination date, the Surety shall not and agrees that any change, extension of time, alteration or addition to the terms of the Contract, including alterations in the work to be done or increase or decrease of the material to be furnished, shall not in any

way release either the Principal or Surety, and Surety hereby waives notice of any such change, extension of time, alteration or addition.

- 9 In the event that suit is brought against this bond, the Surety will pay, in addition to the penal sum herein, costs and reasonable expenses and fees, including reasonable attorney's fees, as awarded and fixed by the court

Signed and sealed this 18th day of June, 2018

Ware Disposal, Inc

Principal

BY: [Signature] (Seal)

SUDITH WARE, PRESIDENT
Name and Title

RLI Insurance Company

Surety

BY: [Signature] (Seal)

[Signature]

Attorney-in-fact

BY: [Signature]

REN WARE, VICE PRESIDENT/SECRETARY
Name and Title

APPROVED AS TO FORM.

MARY C. WICKHAM
County Counsel

BY:

[Signature]
Deputy

POWER OF ATTORNEY

R.I. Insurance Company Contractors Bonding and Insurance Company

9025 N. Lindbergh Dr. Peoria, IL 61615
Phone 800-645-2402

Know All Men by These Presents:

That this Power of Attorney is not valid or in effect unless attached to the bond which it authorizes executed, but may be detached by the approving officer if desired.

That **R.I. Insurance Company** and/or **Contractors Bonding and Insurance Company**, each an Illinois corporation, (separately and together, the "Company") do hereby make, constitute and appoint:

Kenneth A. Coate, Julia B. Haes, jointly or severally

in the City of Riverside, State of California its true and lawful Agent(s) and Attorney(s) in Fact, with full power and authority hereby conferred, to sign, execute, acknowledge and deliver for and on its behalf as Surety, in general, any and all bonds and undertakings in an amount not to exceed Twenty Five Million Dollars (\$25,000,000.00) for any single obligation

The acknowledgment and execution of such bond by the said Attorney in Fact shall be as binding upon the Company as if such bond had been executed and acknowledged by the regularly elected officers of the Company.

R.I. Insurance Company and/or **Contractors Bonding and Insurance Company**, as applicable, have each further certified that the following is a true and exact copy of a Resolution adopted by the Board of Directors of each such corporation, and is now in force, to wit:

"All bonds, policies, undertakings, Powers of Attorney or other obligations of the corporation shall be executed in the corporate name of the Company by the President, Secretary, any Assistant Secretary, Treasurer, or any Vice President, or by such other officers as the Board of Directors may authorize. The President, any Vice President, Secretary, any Assistant Secretary, or the Treasurer may appoint Attorneys in Fact or Agents who shall have authority to issue bonds, policies or undertakings in the name of the Company. The corporate seal is not necessary for the validity of any bonds, policies, undertakings, Powers of Attorney or other obligations of the corporation. The signature of any such officer and the corporate seal may be printed by facsimile."

IN WITNESS WHEREOF, the **R.I. Insurance Company** and/or **Contractors Bonding and Insurance Company**, as applicable, have caused these presents to be executed by its respective Vice President with its corporate seal affixed this 22nd day of May, 2018.



**R.I. Insurance Company
Contractors Bonding and Insurance Company**

By: B.W.D.
Barton W. Davis Vice President

State of Illinois }
County of Peoria } ss

On this 22nd day of May, 2018, before me, a Notary Public, personally appeared Barton W. Davis, who being by me duly sworn, acknowledged that he signed the above Power of Attorney as the aforesaid officer of the **R.I. Insurance Company** and/or **Contractors Bonding and Insurance Company** and acknowledged said instrument to be the voluntary act and deed of said corporation.

By: Mitchell L. Johnson
Cretchen L. Johnson Notary Public

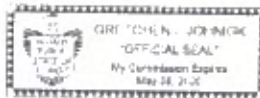

CERTIFICATE

I, the undersigned officer of **R.I. Insurance Company** and/or **Contractors Bonding and Insurance Company**, do hereby certify that the attached Power of Attorney is in full force and effect and is irrevocable; and furthermore, that the Resolution of the Company as set forth in the Power of Attorney, is now in force. In testimony whereof, I have hereunto set my hand and the seal of the **R.I. Insurance Company** and/or **Contractors Bonding and Insurance Company** this 22nd day of May, 2018.

**R.I. Insurance Company
Contractors Bonding and Insurance Company**

By: Jean M. Stephenson
Jean M. Stephenson Corporate Secretary

CALIFORNIA ALL-PURPOSE ACKNOWLEDGMENT

CIVIL CODE § 1189

A notary public or other officer completing this certificate verifies only the identity of the individual who signed the document to which this certificate is attached, and not the truthfulness, accuracy, or validity of that document.

State of California
 County of Riverside
 On JUN 18 2018 before me, R. Balderas, Notary Public
 Date Here Insert Name and Title of the Officer
 personally appeared Julia B. Sales
 Name(s) of Signer(s)

who proved to me on the basis of satisfactory evidence to be the person(s) whose name(s) is/are subscribed to the within instrument and acknowledged to me that he/she/they executed the same in his/her/their authorized capacity(ies), and that by his/her/their signature(s) on the instrument the person(s), or the entity upon behalf of which the person(s) acted, executed the instrument.

I certify under PENALTY OF PERJURY under the laws of the State of California that the foregoing paragraph is true and correct.

WITNESS my hand and official seal.

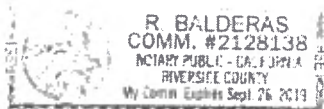

Signature R. Balderas
 Signature of Notary Public

Place Notary Seal Above

OPTIONAL

Though this section is optional, completing this information can deter alteration of the document or fraudulent reattachment of this form to an unintended document.

Description of Attached Document

Title or Type of Document: _____ Document Date: _____
 Number of Pages: _____ Signer(s) Other Than Named Above: _____

Capacity(ies) Claimed by Signer(s)

Signer's Name: <u>Julia B. Sales</u>	Signer's Name: <u>Julia B. Sales</u>
<input type="checkbox"/> Corporate Officer — Title(s): _____	<input type="checkbox"/> Corporate Officer — Title(s): _____
<input type="checkbox"/> Partner — <input type="checkbox"/> Limited <input type="checkbox"/> General	<input type="checkbox"/> Partner — <input type="checkbox"/> Limited <input type="checkbox"/> General
<input type="checkbox"/> Individual <input checked="" type="checkbox"/> Attorney in Fact	<input type="checkbox"/> Individual <input type="checkbox"/> Attorney in Fact
<input type="checkbox"/> Trustee <input type="checkbox"/> Guardian or Conservator	<input type="checkbox"/> Trustee <input type="checkbox"/> Guardian or Conservator
<input type="checkbox"/> Other: _____	<input type="checkbox"/> Other: _____
Signer Is Representing: _____	Signer Is Representing: _____

CALIFORNIA ALL-PURPOSE ACKNOWLEDGMENT

CIVIL CODE § 1189

A notary public or other officer completing this certificate verifies only the identity of the individual who signed the document to which this certificate is attached, and not the truthfulness, accuracy, or validity of that document.

State of California)
County of ORANGE)
On June 23, 2018 before me, J.B. Swan III, Notary Public
personally appeared JUDITH WARE & BEN WARE
Name(s) of Signer(s)

who proved to me on the basis of satisfactory evidence to be the person(s) whose name(s) is/are subscribed to the within instrument and acknowledged to me that he/she/they executed the same in his/her/their authorized capacity(ies), and that by his/her/their signature(s) on the instrument the person(s), or the entity upon behalf of which the person(s) acted, executed the instrument.

I certify under PENALTY OF PERJURY under the laws of the State of California that the foregoing paragraph is true and correct.

WITNESS my hand and official seal



Signature [Handwritten Signature]
Signature of Notary Public

Place Notary Seal Above

OPTIONAL

Though this section is optional, completing this information can deter alteration of the document or fraudulent reattachment of this form to an unintended document

Description of Attached Document
Title or Type of Document: Bond for Faithful Performance Document Date: 06/18/2018
Number of Pages: 2 Signer(s) Other Than Named Above:

Capacity(ies) Claimed by Signer(s)
Signer's Name: JUDITH WARE
Signer's Name: BEN WARE
Corporate Officer - Title(s)
Partner - Limited General
Individual Attorney in Fact
Trustee Guardian or Conservator
Other:
Signer is Representing

Ware Disposal Inc.

Lennox GDD

Exhibit 3D-Contractor Documentation

Item B.7 – INTERNAL REVENUE SERVICE NOTICE 1015

This item consists of 2 pages (including this page).

**Department of the Treasury
Internal Revenue Service
Notice 1015**

(Rev. December 2005)

**Have You Told Your Employees About the
Earned Income Credit (EIC)?**

What is the EIC?

The EIC is a refundable tax credit for certain workers.

Which Employees Must I Notify About the EIC?

You must notify each employee who worked for you at any time during the year and from whom you did not withhold income tax. However, you do not have to notify any employee who claimed exemption from withholding on Form W-4, Employee's Withholding Allowance Certificate.

Note: You are encouraged to notify each employee whose wages for 2005 are less than \$37,263 that he or she may be eligible for the EIC.

How and When Must I Notify My Employees?

You must give the employee one of the following:

- The IRS Form W-2, Wage and Tax Statement, which has the required information about the EIC on the back of Copy B.
- A substitute Form W-2 with the same EIC information on the back of the employee's copy that is on Copy B of the IRS Form W-2.
- Notice 797, Possible Federal Tax Refund Due to the Earned Income Credit (EIC).
- Your written statement with the same wording as Notice 797.

If you are required to give Form W-2 and do so on time, no further notice is necessary if the Form W-2 has the required information about the EIC on the back of the employee's copy. If a substitute Form W-2 is given on time but does not have the required information, you must notify the employee within 1 week of the date the substitute Form W-2 is given. If Form W-2 is required but is not given on time, you must give the employee Notice 797 or your written statement by the date Form W-2 is required to be given. If Form W-2 is not required, you must notify the employee by February 7, 2006.

You must hand the notice directly to the employee or send it by First-Class Mail to the employee's last known address. You will not meet the notification requirements by posting Notice 797 on an employee bulletin board or sending it through office mail. However, you may want to post the notice to help inform all employees of the EIC. You can get copies of the notice by calling 1-800-829-3676, or from the IRS website at www.irs.gov.

**How Will My Employees Know If They Can
Claim the EIC?**

The basic requirements are covered in Notice 797. For more detailed information, the employee needs to see the 2005 Instructions for Form 1040, 1040A, 1040EZ, or Pub. 586, Earned Income Credit (EIC).

How Do My Employees Claim the EIC?

Eligible employees claim the EIC on their 2005 tax return. Even employees who have no tax withheld from their pay or owe no tax can claim the EIC and get a refund, but they must file a tax return to do so. For example, if an employee has no tax withheld in 2005 and owes no tax but is eligible for a credit of \$799, he or she must file a 2005 tax return to get the \$799 refund.

**How Do My Employees Get Advance EIC
Payments?**

Eligible employees who expect to have a qualifying child for 2006 can get part of the credit with their pay during the year by giving you a completed Form W-5, Earned Income Credit Advance Payment Certificate. You must include advance EIC payments with wages paid to those employees, but the payments are not wages and are not subject to payroll taxes. Generally, the payments are made from withheld income, social security, and Medicare taxes. For details, see Pub. 15 (Circular E), Employer's Tax Guide.

**Notice 1015
(Rev. 12-2005)**

Cat No 30599B

Ware Disposal Inc.

Lennox GDD

Exhibit 3D-Contractor Documentation

Item B.8 – CONTRACTOR’S EEO CERTIFICATION

This item consists of 2 pages (including this page).

FORM PW-7

BIDDER'S EQUAL EMPLOYMENT OPPORTUNITY CERTIFICATION

Bidder's Name	WARE DISPOSAL INC.
Address	1451 MANHATTAN AVENUE, FULLERTON, CALIFORNIA 92831 5221
Internal Revenue Service Employer Identification Number	95 374 3725

In accordance with Los Angeles County Code, Section 4.32.010, the Bidder certifies and agrees that all persons employed by it, its affiliates, subsidiaries, or holding companies are and will be treated equally by the firm without regard to or because of race, religion, ancestry, national origin, or sex and in compliance with all antidiscrimination laws of the United States of America and the State of California.

1.	The bidder has a written policy statement prohibiting any discrimination in all phases of employment.	<input checked="" type="checkbox"/> YES <input type="checkbox"/> NO
2.	The bidder periodically conducts a self-analysis or utilization analysis of its work force.	<input checked="" type="checkbox"/> YES <input type="checkbox"/> NO
3.	The bidder has a system for determining if its employment practices are discriminatory against protected groups.	<input checked="" type="checkbox"/> YES <input type="checkbox"/> NO
4.	Where problem areas are identified in employment practices, the bidder has a system for taking reasonable corrective action to include establishment of goals and timetables.	<input checked="" type="checkbox"/> YES <input type="checkbox"/> NO

Bidder	WARE DISPOSAL INC.	
Authorized representative	JUDITH HELAINE WARE	
Signature		Date 9 MAY 2018

Ware Disposal Inc.

Lennox GDD

Exhibit 3D-Contractor Documentation

Item B.9 – INTENTIONALLY OMITTED

Exhibit 3D-Contractor Documentation

Item B.10 – SHARPS COLLECTION

This item consists of 2 pages (including this page).

Sharps Collection Program

Within one week after residential customers' request, Ware Disposal Inc. will provide said subscription customer, at the customers' residential premises, without surcharge to the County or customer, an approved container for sharps disposal in accordance with Applicable Laws.

Ware Disposal Inc. will provide 1 gallon and/or 2 gallon SHARP containers pre-approved by the County of Los Angeles. Upon request by the subscriber, Ware Disposal Inc. personnel will personally and promptly deliver an empty Sharps container kit.

Each kit includes:

1. A government-approved plastic container specially-designed for sharps waste
2. Postage-prepaid mail-back shipping box
3. Pre-addressed shipping labels
4. Prepaid disposal

Ware Disposal Inc. has identified BD Sharps Disposal by Mail (WMI) as their container and autoclave vendor for sharps disposal. BD Sharps Disposal by Mail (WMI) is the nation's largest supplier and processor of medical and sharps waste.

Once the pre-approved container is full, the subscriber completes a simple tracking form and ships the container back to BD Sharps Disposal by Mail (WMI) in the mail-back box. Upon receipt, BD Sharps Disposal by Mail (WMI) documents the delivery and properly treats and destroys the sharps container and its contents. It's convenient, safe, and confidential.

Upon shipment to BD Sharps Disposal by Mail (WMI), the subscriber shall be required to contact Ware Disposal Inc. for a new replacement container. Ware Disposal Inc. shall distribute the 1-gallon or 2-gallon containers to each subscriber up to four times per year. If multiple residents in the same dwelling require additional capacity, Ware Disposal Inc. may increase the container size and/or frequency upon mutual agreement with the subscriber, County staff and Ware Disposal Inc. management.

Ware Disposal Inc. will collect, transport and dispose of materials in accordance with Applicable Laws and will provide the following:

- a. Distribution of County approved Sharps containers (to include outreach efforts)
- b. Collections of Sharps containers
- c. Proper handling and disposal of containers in accordance with Applicable Laws.

Ware Disposal Inc.

Lennox GDD

Exhibit 3D-Contractor Documentation

Item B.11 – MULCH AND COMPOST GIVEAWAY PROGRAM

This item consists of 2 page (including this page).

Ware Disposal Inc. will, twice annually, publicize and offer occupants mulch and compost at no additional charge to customers, occupants or County. This will occur once in the early Spring and again in the early Fall or at alternate dates as requested or approved by the Director. Ware Disposal Inc. will use reasonable business efforts to offer mulch and compost that have been produced by the Lennox GDD community.

Ware Disposal Inc. will offer at least 40 cubic yards of mulch and 40 cubic yards of compost at each event, or any volume requested by the Director not to exceed 80 cubic yards of mulch and 80 cubic yards of compost per event.

Ware Disposal Inc. will comply with the California Department of Food and Agriculture's quarantine restrictions for the movement of green waste.

Ware Disposal Inc.

Lennox GDD

Exhibit 3D-Contractor Documentation

Item B.12 – NO LONGER USED

This item consists of 1 page (including this page).

Exhibit 3D-Contractor Documentation

Item B.13 – DIRECTOR-APPROVED SUBCONTRACTORS

This item consists of 1 page (including this page).

None to report.

Ware Disposal Inc.

Lennox GDD

Exhibit 3D-Contractor Documentation

Item B.14 – BACKUP SERVICE PLAN

This item consists of 3 pages (including this page).

Item B.14 — BACKUP SERVICE PLAN

Backup Service Plan

WARE DISPOSAL INC. shall implement its Backup Service Plan within seven days of Director request if Customer's Solid Waste is not Collected at Customer's Set-Out Site or Abandoned Waste is not Collected for any reason, including uncontrollable circumstances. An example is if WARE DISPOSAL INC.'S drivers strike or it is not possible to provide Contract Services in difficult to service areas due to severe weather conditions, especially on hillsides. In the event there is a protracted service disruption due to any cause, WARE DISPOSAL INC. will institute many proactive actions to sustain Solid Waste Collection Services. Since Customers are expecting Collection, Transportation, and Disposal services that WARE DISPOSAL INC. is not providing, WARE DISPOSAL INC. shall not charge Customer or COUNTY for any of the services described below.

1. Provide Conveniently Located Dumpsters or Roll-off Containers

WARE DISPOSAL INC. will place 3 or 4-yard Dumpsters and/or roll-off Containers throughout the community in key locations approved by Director.

2. Offer Self-Hauling Solid Waste to a Facility

WARE DISPOSAL INC. will use Reasonable Business Efforts to make arrangements with the solid waste facility normally used by WARE DISPOSAL INC. for this Contract, to allow each Occupant to direct haul and dispose of their solid waste 6 days per week. WARE DISPOSAL INC. shall only charge the Customer for disposal costs for quantities beyond the Customer's normal service levels as evident in a copy of a recent bill provided by the Customer or Occupant. For example, a resident with 96-gallon Refuse, Recyclables and Green Waste Carts may dispose up to 0.5 cubic yards of Refuse and Divert up to 0.5 cubic yards of Recyclables and Green Waste each week at no charge.

Additionally, if Director determines the distance to the facilities is too far from Occupants, WARE DISPOSAL INC. will arrange for a local facility to allow each Occupant to drop-off the Solid Waste.

3. Inform Customers of Temporary Procedures

WARE DISPOSAL INC. guarantees the above service and disposal options will be made readily available to each Occupant. WARE DISPOSAL INC. will provide Customers and Occupants with information on where and how to dispose of their solid waste by the following means:

- A phone option on its customer service line to hear a taped looped message.
- Arrange for the broadcast of COUNTY'S 30-second Public Service Announcement video on local cable access channels with WARE DISPOSAL

- INC. to customize it to the situation, such as having text appear on the screen announcing date, times, and addresses.
- Contact local print media and produce a press release.
- Contact Customers and Occupants via phone, email, or text messages.

4. Credit Policy for Missed Contract Services

a. Missed Curbside Collection

Since Customer is expecting a Collection Service not provided, WARE DISPOSAL INC. shall automatically credit Customer for each missed collection. For example, if a strike disrupts 2 weeks of the 13 Collections in a quarter, WARE DISPOSAL INC. would credit Customer 2/13 of that quarter's fee toward the next quarter's fee.

b. Other Customer Services

When WARE DISPOSAL INC. is unable to offer Customer Services other than curbside collection, such as Annual Curbside Cleanup, Mulch/Compost Giveaway events, or other required services, WARE DISPOSAL INC. shall provide evidence of cost associated with those services and offer alternate services acceptable to Director.

5. Provide Replacement Drivers and Security

WARE DISPOSAL INC. shall use Reasonable Business Efforts to require all properly trained and licensed employees to operate Collection Vehicles to maintain core Disposal and Diversion services. As described in the above paragraphs, WARE DISPOSAL INC. shall be properly staffed to provide drop-off services for each Occupant. In addition to WARE DISPOSAL INC. staff, WARE DISPOSAL INC. shall use drivers or Vehicles from other operations and other waste haulers.

Finally, in cases of a strike, WARE DISPOSAL INC. shall work closely with a private security firm to guarantee a safe and consistent operation.

6. Identify Customers Requiring Priority Service

WARE DISPOSAL INC. shall contact the elderly and disabled Occupants with Roll-out Service and shall use Reasonable Business Efforts to collect putrescible Solid Waste from their residence.

Exhibit 3D-Contractor Documentation

Item B.15 –KEY PERSONNEL

This item consists of 3 pages (including this page).

Ware Disposal Inc.

Lennox GDD

CONTRACT SERVICES MANAGERS	
Mr Jay Ware, General Manager	Mr Jason Bryce Rush, Legislative Director
1035 East 4 th Street, Santa Ana, California 92701 4750	1035 East 4 th Street, Santa Ana, California 92701 4750
T 714 664 0677 x105 M 714 906 2887	T 714 664 0677 x100 M 714 906 2403
jay@wardisposal.com	jason@wardisposal.com
AUTHORIZED REPRESENTATIVES	
Mr Jay Ware, General Manager	Mr Jason Bryce Rush, Legislative Director
1035 East 4 th Street, Santa Ana, California 92701 4750	1035 East 4 th Street, Santa Ana, California 92701 4750
T 714 664 0677 x105 M 714 906 2887	T 714 664 0677 x100 M 714 906 2403
jay@wardisposal.com	jason@wardisposal.com
LEAD PERSONS	
Mr Manuel Gonzales, Senior Operations Manager	Mr Jay Ware, General Manager
1451 Manhattan Avenue, Fullerton, California 92831 5221	1035 East 4 th Street, Santa Ana, California 92701 4750
T 714 664 0677 x113 M 714 488 0866	T 714 664 0677 x105 M 714 906 2887
manny@wardisposal.com	jay@wardisposal.com
EMERGENCY CONTACT (outside Contractor's office hours)	
Mr Jay Ware, General Manager	
M 714 906 2887 jay@wardisposal.com	
KEY PERSONNEL	
Mr Jay Ware, General Manager	Mr Jason Bryce Rush, Legislative Director
1035 East 4 th Street, Santa Ana, California 92701 4750	1035 East 4 th Street, Santa Ana, California 92701 4750
T 714 664 0677 x105 M 714 906 2887	T 714 664 0677 x100 M 714 906 2403
jay@wardisposal.com	jason@wardisposal.com
Mr Manuel Gonzales, Senior Operations Manager	Mr Brad Timmons, Senior Sales Manager
1451 Manhattan Avenue, Fullerton, California 92831 5221	1035 East 4 th Street, Santa Ana, California 92701 4750
T 714 664 0677 x113 M 714 488 0866	T 714 664 0677 x123 M 949 636 9741
manny@wardisposal.com	brad@wardisposal.com

Ware Disposal Inc.

Lennox GDD

Ms Nicole Seyle, Recycling Coordinator	Mr Antonio Mejia, Residential Route Supervisor
1740 South Los Angeles Street, Suite 212, Los Angeles, California 90015 3658	1451 Manhattan Avenue, Fullerton, California 92831 5221
T 213 275 1146 x123 M 714 425 2680	T 714 664 0677 x104 M 714 454 3662
nicole@wardisposal.com	tony@wardisposal.com
Mr Edward Lara, Bulky Item Collection Supervisor	Mr Ivan de Jesus Buelna, Mechanic Supervisor
1451 Manhattan Avenue, Fullerton, California 92831 5221	1451 Manhattan Avenue, Fullerton, California 92831 5221
T 714 664 0677 x114 M 714 713 8638	T 714 664 0677 M 714 612 4204
eddie@wardisposal.com	ivan@wardisposal.com
Ms Monique Rodriguez, Lennox GDD CSR Manager	Mr Jose Lazaro, Senior CSR Manager
1035 East 4 th Street, Santa Ana, California 92701 4750	1035 East 4 th Street, Santa Ana, California 92701 4750
T 714 664 0677 x116, M to be assigned	T 714 664 0677 x 121 M 714 710 2469
monique@wardisposal.com	jose@wardisposal.com
Mr Jose Chavez, Project Coordinator/H.R.	Mr Michael Shaffer, Chief Financial Officer
1035 East 4 th Street, Santa Ana, California 92701 4750	1035 East 4 th Street, Santa Ana, California 92701 4750
T 714 664 0677 x443 M 714 343 7033	T 714 664 0677 x118 M 949 836 2374
josec@wardisposal.com	michael@wardisposal.com
Yolanda Mora, Senior A/R Manager	Judith Helaine Ware, President
1035 East 4 th Street, Santa Ana, California 92701 4750	1035 East 4 th Street, Santa Ana, California 92701 4750
T 714 664 0677 x102 M 714 785 7845	T 714 664 0677 x106, M 714 906 5839
yolanda@wardisposal.com	judith@wardisposal.com
SERVICES SAFETY OFFICIAL	
Mr Manuel Gonzales, Senior Operations Manager	
1451 Manhattan Avenue, Fullerton, California 92831 5221	
T 714 664 0677 x113 M 714 488 0866	
manny@wardisposal.com	

Ware Disposal Inc.

Lennox GDD

Exhibit 3D-Contractor Documentation

Item B.16 – ROUTE MAPS AND SCHEDULES

This item consists of 3 pages (including this page).

START AND END POINTS FOR COLLECTION

Monday Route 1: 4054 West 103d Street to 4115 West 107th Street
Monday Route 2: 10814 Acacia Avenue to 5215 West 120th Street
Tuesday Route 1: 10826 Eastwood Avenue to 4656 West 111th Street
Tuesday Route 2: 4532 West 111th Street to 4517 West 111th Street
Wednesday Route 1: 10122 Mansel Avenue to 4618 West 104th Street
Wednesday Route 2: 10224 Firmana Avenue to 4518 West 104th Street
Thursday Route 1: 10721 Buford Avenue to 4834 West 112th Street
Thursday Route 2: 4952 West 104th Street to 5026 West 106th Street
Friday Route 1: 10914 Truro Avenue to 4915 West 112th Street
Friday Route 2: 4960 West 112th Street to 5010 West 112th Street

Exhibit 3D-Contractor Documentation

Item B.17 – FACILITIES AND SOLID WASTE FACILITIES

This item consists of 10 pages (including this page).

**REFUSE DIRECT: PUENTE HILLS MATERIAL RECOVERY FACILITY
19-AA-1043**

Sanitation Districts of Los Angeles County
2808 South Workman Mill Road
Whittier, California 90601

Mr Bob Asgian, Supervising Engineer
T 562 699 7315 x6056
rasgian@lacsds.org

**RECYCLING PRIMARY: PUENTE HILLS MATERIAL RECOVERY FACILITY
19-AA-1043**

Sanitation Districts of Los Angeles County
2808 South Workman Mill Road
Whittier, California 90601

Mr Bob Asgian, Supervising Engineer
T 562 699 7315 x6056
rasgian@lacsds.org

**RECYCLING SECONDARY: MADISON MATERIALS INC.
30-AB-0386**

1035 East 4th Street
Santa Ana, California 92701

Mr Jay Ware, General Manager
T 714 664 0159 x105
jay@waredisposal.com

**GREEN WASTE PRIMARY: PUENTE HILLS MATERIAL RECOVERY FACILITY
19-AA-1043**

Sanitation Districts of Los Angeles County
2808 South Workman Mill Road
Whittier, California 90601

Mr Bob Asgian, Sanitation Districts of Los Angeles County
T 562 699 7315 x6056
rasgian@lacsds.org

**GREEN WASTE SECONDARY: MADISON MATERIALS INC.
30-AB-0386**

1035 East 4th Street
Santa Ana, California 92701

Mr Jay Ware, General Manager
T 714 664 0159 x105
jay@waredisposal.com

BULKY ITEM WASTE/ELECTRONIC AND UNIVERSAL WASTE: MADISON MATERIALS INC.

30-AB-0386

1035 East 4th Street
Santa Ana, California 92701

Mr Jay Ware, General Manager
T 714 664 0159 x105
jay@waredisposal.com

CONSTRUCTION AND DEMOLITION WASTE: MADISON MATERIALS INC.

30-AB-0386

1035 East 4th Street
Santa Ana, California 92701

Mr Jay Ware, General Manager
T 714 664 0159 x105
jay@waredisposal.com

RECYCLING RESIDUAL DISPOSAL: FRANK R BOWERMAN LANDFILL

30-AB-0360

11002 Bee Canyon Access Road
Irvine, California 92602

Ms Isabel Rios-Kahn
714 834 4000
Isabel.rios-kahn@ocwr.ocgov.com

TYPES OF MATERIALS ACCEPTED/REJECTED:

PUENTE HILLS MATERIAL RECOVERY FACILITY:

TYPES OF WASTE ACCEPTED

A variety of different types of waste and recyclables are accepted, including:

- Residential waste
- Commercial waste
- Industrial waste
- Construction and demolition waste

TYPES OF RECYCLABLES THAT ARE PAID FOR OR ACCEPTED AT A REDUCED TIPPING FEE

Some recyclables are accepted at either reduced tipping fees, while others can receive a cash payment. These recyclables include:

- Greenwaste
- Newspaper
- Cardboard

- Mixed paper
- Mixed recyclables containing scrap metal, scrap plastics, bottles, aluminum cans, cardboard, paper, etc.
- Mixed rigid plastics (plastic buckets, crates, children's toys, etc.)

TYPES OF RECYCLABLES THAT ARE RECOVERED

A variety of recyclables are recovered. While some can receive a cash payment or a reduced tipping fee (as listed above), various types of recyclables are recovered, including the following:

- Greenwaste
- Newspaper
- Cardboard
- Mixed paper
- Mixed rigid plastics
- Mattresses
- Wood waste
- Carpet and carpet padding
- Scrap metal
- Beverage containers with redemption value (glass, plastic and aluminum)
- Tin cans
- Asphalt, dirt, and concrete

UNACCEPTABLE MATERIAL THAT WILL BE REJECTED:

- Whole tires from motorcycles, cars and trucks
- Liquid waste
- Hazardous materials, chemicals, or paint
- Salt/brine, detergents
- Sandblasting sand, fly ash and all special wastes
- Used oil or material contaminated with oil
- Treated wood waste
- Non-hazardous wastes containing asbestos
- Pharmaceutical (medicines)
- E-waste

MADISON MATERIALS:

Permissions

1. The acceptance and processing of non-hazardous solid waste is limited to construction and demolition waste, commercial solid waste, industrial waste, inert wastes, source separated residential refuse, and separated for reuse recyclables.
2. No more than 25 tons of combined universal waste and electronic waste shall be received at the facility per day.

Prohibitions

1. Madison Materials shall not receive waste from food establishments (e.g., restaurants, grocery stores, cafeterias, etc.) and residential units which has not been source separate to remove all food material and putrescible waste. At no time will Madison Materials have on site any amount of putrescible waste that is contributing to a nuisance as determined by the LEA.
2. Madison Materials is strictly prohibited from accepting the following types of waste: agricultural solid wastes, animal flesh or parts, ashes, biohazardous wastes, biosolids, food material waste, friable asbestos, grease trap pumping, hazardous waste that is not classified as universal waste, incinerator residue, liquid waste, manure, medical waste, oil field operating waste, radioactive waste, semi-solid waste, septic tank pumping, sewage sludge, and street refuse.
3. Scavenging or open burning.
4. Chipping, grinding, or composting.

FRANK R BOWERMAN LANDFILL:

Prohibitions:

The facility operator is prohibited from accepting hazardous, universal, designated, radioactive, liquid (i.e. water content > 50% by weight), or incinerator waste. The facility operator is also prohibited from accepting sludge, biosolids, friable asbestos, commercial loads of tires, white goods, grease trap and septic tank pumpings, or other wastes requiring special treatment or handling, except as identified in the facility's JTD. No medical waste shall be accepted unless autoclaved (sterilized) prior to disposal at the facility, and shall be spread, compacted and covered immediately. Prohibited non-hazardous waste may be accepted only after processing JTD amendment(s), or in circumstances outlined in conditions 17.c, 17.n and 17.q of this permit.

Electronic Waste (CED's) Contractor

SILICON SALVAGE INC.

CEWID NO. 100957

1500 North Dale Avenue

Anaheim, California 92801

Ms Debbie Allen

T 714 523 2425

debbie@siliconsalvage.com

Methodology of Allocating Materials at Madison Materials

Ware Disposal's protocol is based on a comparison of positive sorts done at Madison Materials and then compared to the diversion allocations provided by the subject facility. Our protocol for Conducting Quarterly Diversion Allocation Audits is described below.

Every load brought to a MRF from a jurisdiction is recorded by the jurisdiction of origin at the scale house. Incoming loads from the County will be deposited on the tipping floor. These loads are not mixed with any other jurisdictions' until the point of processing as it is infeasible to separate and process each jurisdiction's loads separately. Madison Materials has employed a process for allocating tonnage to each city that receives diversion credit. This allocation system is quite similar to that found at other Orange County transfer stations. It has been formulated to be as transparent as it can be as it relates to mixed material recovery facility processing. This type of methodology has already been reviewed by the Orange County Waste and Recycling (OCIWMD) and is consistent with existing policies regarding said issue of the California Resources Recycling and Recovery (Cal-Recycle).

The County's allocation percentage is established as follows. Ware Disposal (through Madison Materials) will separate loads from the County and will characterize the loads in the following order of residential recyclables, commercial, and roll-off (construction and demolition). Each characterization is accomplished by hand sort, and weights are

established for each of the three waste categories. A five-day sampling is conducted to account for changes in the waste stream over the course of a week. These daily samples are then averaged to produce a quarterly characterization that is used to establish the allocation percentage for the County. This characterization process is repeated every quarter to establish the next quarter's allocation to account for seasonal fluctuations. Madison Materials has run tests on the jurisdictions it currently services and the testing has proven to be successful and has resulted in diversion rates in excess of 50%.

The recyclable commodities from this process are recovered paper, cardboard, newsprint, plastics 1-7, scrap metal, non-ferrous metals, aluminum, wood, green waste, drywall, concrete, dirt, asphalt, roofing materials and other assorted recyclable materials. Madison Materials has a successful track record over the past ten (10) years in marketing all of the aforementioned commodities. The results of this recovery process will be reported to the County of Los Angeles as specified in the franchise agreement.



Allocation Methodology for Calculating Diversion for Source Separated Commingled Recyclables at the PHMRF and DART

The County Sanitation Districts of Los Angeles County (Districts) own and operate the Downey Area Recycling and Transfer Facility (DART) located in the City of Downey, and the Puente Hills Materials Recovery Facility (PHMRF) located in an unincorporated portion of Los Angeles County near the City of Whittier.

A. Description of Recovery at the PHMRF and DART:

The DART facility has two sorting systems and the PHMRF has one sorting system. All inbound loads of commingled recyclable materials are weighed, inspected and dumped in the tipping area of the facilities. At the facility's weigh scale station, a computer transaction is created and the hauler, type of material, jurisdiction of origin and net weight of each load is recorded. Each load is inspected after it is dumped in order to ensure that it meets quality standards. The loads are then pushed in to a pile with other loads of commingled recyclables. Front end loaders are used to push the material onto a conveyor which feeds the manual and/or mechanical sorting systems.

At these sorting systems, recyclable materials are separated and placed into dedicated bunkers or bins and the residual waste is conveyed back to the tipping area for disposal. Commodities recovered may include, but are not limited to, cardboard, mixed paper, aluminum cans, HDPE color containers, HDPE natural containers, PETE containers, mixed rigid plastics, scrap metal and glass. The recyclable materials are either shipped directly to markets in bulk (if not baleable), or are conveyed to a baler to be baled. Baled recyclables are loaded into containers and then shipped to markets. For

each load of recyclables shipped out, a computer transaction is created at the facility's weigh scale station, and the destination, material type and net weight is recorded.

B. Description of the Allocation Methodology:

Incoming Tonnage: The PHMRF and DART receive source separated commingled recyclable materials from multiple haulers and jurisdictions. Each load's jurisdiction of origin is identified by the hauler's driver and recorded at the facility's weigh scale station. Therefore, the weights from each incoming jurisdiction are tracked separately.

Waste Characterizations: On at least a quarterly basis, characterizations are performed on samples of source separated recyclables from each hauler and each jurisdiction. Random samples are taken from three loads for each hauler and each jurisdiction. The samples are sorted and weights are measured for the following: cardboard, mixed paper, PETE, HDPE color, HDPE natural, aluminum cans, glass, scrap metal, mixed rigid plastics and residual (non recoverables). The weights from the samples are used to calculate individual characterization percentages by commodity type for source separated recyclables delivered from each hauler and jurisdiction.

Methodology and Calculation: For each hauler and jurisdiction, the characterizations are multiplied by their respective monthly inbound tons delivered to come up with their theoretical tons produced. Each hauler and jurisdiction's theoretical tons produced is then divided by the total theoretical tons produced from all haulers and all jurisdictions to come up with the proportionate share of the total diversion percentage that will be assigned to each individual hauler and jurisdiction. The actual total monthly tons diverted, as measured by the outbound scales, are then multiplied by the proportionate share of diversion for each individual hauler and jurisdiction. With this method, each month, diversion is reconciled to the actual tons of recyclables produced at each facility.

SAMPLE INVOICE – TRASH - PUENTE HILLS LANDFILL

Report RDX026
Page 6612?
Date 02/06/2018

REFUSE DISPOSAL SYSTEM
Account Transaction Summary
January 2018

87137 - WARE DISPOSAL CO

Facility	Transaction Date/Time	Transactions	Vehicle ID	Refuse Type	Gross Weight	Tare Weight	Net Weight	Amount	Contract Amount	Contract Credit
Puente Hills MRF	01/02/2018 09:59 AM	900898125	612JAL	Minimum Load	14.97	14.54	0.43	\$49.84	\$20.54	\$29.30
Puente Hills MRF	01/02/2018 11:07 AM	900898184	6N8B52	Refuse	23.45	16.20	7.25	\$423.40	\$346.26	\$77.14
Puente Hills MRF	01/02/2018 11:43 AM	900898209	3671001	Refuse	27.72	17.05	10.67	\$623.13	\$509.51	\$113.62
Puente Hills MRF	01/02/2018 11:54 AM	900898212	61234A2	Minimum Load	15.27	14.86	0.41	\$49.64	\$19.98	\$29.66
Puente Hills MRF	01/02/2018 12:33 PM	900898221	99571B2	Refuse	16.16	14.50	1.66	\$133.15	\$106.89	\$26.26
Puente Hills MRF	01/02/2018 01:30 PM	900898254	6N8B52	Greenwaste	21.51	16.24	5.27	\$209.78	\$194.46	\$15.32
Puente Hills MRF	01/02/2018 02:01 PM	900898318	90571B2	Refuse	17.14	14.48	2.66	\$155.34	\$127.04	\$28.30
Puente Hills MRF	01/02/2018 03:03 PM	900898343	61234A2	Refuse	16.83	13.92	2.91	\$189.94	\$138.98	\$50.96
Puente Hills MRF	01/02/2018 03:22 PM	900898401	6597448	ICCR in Com Commingled Re	23.66	18.84	4.82	\$0.00	\$0.00	\$0.00
Puente Hills MRF	01/02/2018 03:28 PM	900898405	99571B2	Refuse	18.20	13.08	5.12	\$7.00	\$244.53	\$244.48
Puente Hills MRF	01/02/2018 03:38 PM	900898405	3121001	Refuse	28.84	17.05	11.79	\$668.54	\$663.09	\$5.45
Puente Hills MRF	01/02/2018 04:43 PM	900898409	70J48N1	Refuse	25.45	17.97	7.48	\$436.83	\$357.24	\$79.59
Puente Hills MRF	01/03/2018 05:37 AM	900898447	8772N1	Refuse	28.05	19.11	8.94	\$322.10	\$428.96	\$106.86
Puente Hills MRF	01/03/2018 05:47 AM	900898492	3820601	Refuse	22.31	16.87	5.44	\$317.70	\$258.82	\$58.88
Puente Hills MRF	01/03/2018 05:47 AM	900898494	9E73772	Refuse	27.15	16.21	10.94	\$522.10	\$426.98	\$95.12
Puente Hills MRF	01/03/2018 05:51 AM	900898484	9903642	Refuse	29.49	17.10	12.39	\$545.46	\$446.06	\$99.40
Puente Hills MRF	01/03/2018 06:03 AM	900898505	8778N1	Refuse	20.35	14.76	5.59	\$328.46	\$378.83	\$50.37
Puente Hills MRF	01/03/2018 06:23 AM	900898520	9H8B52	Greenwaste	18.41	18.37	0.04	\$92.82	\$268.98	\$176.16
Puente Hills MRF	01/03/2018 06:49 AM	900898541	9973882	Refuse	20.94	12.50	8.44	\$492.90	\$75.28	\$317.62
Puente Hills MRF	01/03/2018 06:57 AM	900898545	6H8B52	ICCR in Com Commingled Re	20.06	18.24	1.82	\$0.00	\$403.14	\$399.22
Puente Hills MRF	01/03/2018 07:03 AM	900898549	9583702	Refuse	23.53	16.41	7.12	\$415.81	\$340.05	\$75.76
Puente Hills MRF	01/03/2018 07:24 AM	900898583	15013E1	Refuse	14.41	13.09	1.32	\$77.09	\$63.05	\$14.04
Puente Hills MRF	01/03/2018 08:09 AM	900898581	61234A2	Refuse	16.80	12.50	4.30	\$239.44	\$195.82	\$43.62
Puente Hills MRF	01/03/2018 08:09 AM	900898592	61234A2	Refuse	16.58	14.99	1.59	\$110.38	\$90.21	\$20.17
Puente Hills MRF	01/03/2018 08:12 AM	900898584	3821001	Refuse	28.39	17.05	11.34	\$659.42	\$536.83	\$122.59
Puente Hills MRF	01/03/2018 08:17 AM	900898598	61155Y1	Refuse	27.84	17.80	10.04	\$585.34	\$479.51	\$105.83
Puente Hills MRF	01/03/2018 08:27 AM	900898604	9122307	Refuse	14.28	13.44	0.84	\$49.64	\$40.60	\$9.04
Puente Hills MRF	01/03/2018 09:19 AM	900898637	23437S1	Refuse	25.25	15.34	9.91	\$403.54	\$330.02	\$73.52
Puente Hills MRF	01/03/2018 09:43 AM	900898655	31293E2	Refuse	19.26	14.06	5.20	\$303.68	\$248.35	\$55.33
Puente Hills MRF	01/03/2018 09:53 AM	900898656	3821001	Refuse	27.92	17.05	10.87	\$611.45	\$500.05	\$111.40
Puente Hills MRF	01/03/2018 10:01 AM	900898670	15013E1	Refuse	16.35	13.04	3.31	\$183.30	\$158.08	\$25.22
Puente Hills MRF	01/03/2018 10:30 AM	900898678	61234A2	Refuse	18.27	14.89	3.38	\$92.27	\$79.46	\$12.81
Puente Hills MRF	01/03/2018 10:35 AM	900898692	8122113	Refuse	21.38	14.50	6.88	\$402.36	\$329.07	\$73.29
Puente Hills MRF	01/03/2018 10:35 AM	900898705	8772N1	Refuse	28.54	19.11	9.43	\$433.81	\$358.89	\$74.92
Puente Hills MRF	01/03/2018 10:54 AM	900898710	791DAN	Refuse	18.18	12.20	5.98	\$340.21	\$285.60	\$54.61
Puente Hills MRF	01/03/2018 10:54 AM	900898730	9873662	Refuse	23.82	12.50	11.32	\$649.41	\$531.09	\$118.32

SANITATION DISTRICTS OF LOS ANGELES COUNTY
 WEIGHMASTER AUTOMATED TRANSACTION SYSTEM
 Refuse Disposal Customer Activity Report By Name

WVA106Z 3 of 5
 Page
 Date 02/21/2018

From: 01/01/2018 To: 01/31/2018

Licence Plate #	Account Name	Address	City Of Origin	Refuse Type	Loads	Tonnage	Fee
87137	WARE DISPOSAL CO	PO BOX 1318 Santa Ana CA 92702	Anaheim/OrCity	Refuse	2.00	25.48	1,458.03
			Baldwin Park	Refuse	1.00	4.89	285.58
			Bell	Refuse	3.00	29.06	1,697.10
			Befflower	Hard to Handle	10.00	12.87	880.32
				Hard to Handle Minimum	2.00	1.40	119.28
				Minimum Load	2.00	0.64	98.28
				Refuse	166.00	1,542.17	90,082.67
			CHARTER OAK - LACD	Greenwaste	34.00	164.47	7,483.42
				ICCR-In Com Commingled Re	22.00	73.23	0.00
				Refuse	44.00	348.67	20,362.36
			ChatoSan Berdo	ICCR-In Com Commingled Re	7.00	23.51	0.00
			Coalinga	Refuse	1.00	1.52	88.77
			Long Beach	Minimum Load	1.00	0.15	49.64
				Refuse	4.00	12.84	749.85
			Los Angeles	ICCR-In Com Commingled Re	22.00	108.23	0.00
				Refuse	23.00	737.22	8,013.65
			Monterey Pars	Refuse	35.00	287.47	15,620.26
			Pasadena	ICCR-In Com Commingled Re	1.00	4.90	0.00
			Pico Rivera	Refuse	3.00	8.61	502.82
			Pomona	Greenwaste	1.00	2.80	127.40
				ICCR-In Com Commingled Re	3.00	7.81	0.00
				Refuse	56.00	610.32	35,642.68

SAMPLE INVOICE – RECYCLABLES – MADISON MATERIALS



MADISON MATERIALS

CITY OF SANTA ANA C/D DIVERSION REPORT

WARE DISPOSAL INC.

JANUARY 2018

MATERIAL	TONS	PERCENTAGE
CARDBOARD	3.85	0.0384
CARPET	0.23	0.0023
PLASTICS	1.39	0.0139
WOOD	7.14	0.0713
CONCRETE/ASPHALT	12.42	0.1240
STEEL	7.33	0.0732
ALUMINUM	0.21	0.0021
ROOFING MATERIALS	0.82	0.0082
MIXED PAPER	3.29	0.0328
GREEN MATERIALS	5.06	0.0505
AGRICULTURAL COMPOST	31.94	0.3189
TYRES	0.02	0.0002
E WASTE	0.00	0.0000
U WASTE	0.03	0.0003
TREATED WOOD	0.00	0.0000
APPLIANCES	0.04	0.0004
GLASS	0.26	0.0026
COPPER	0.00	0.0000
WIRE NO 1/2	0.23	0.0023
MATTRESSES	0.03	0.0003
ORGANIC FOOD WASTE	1.16	0.0116
RESIDUAL	24.71	0.2467
TOTAL	100.17	1.0000

P.O. Box 1106 Santa Ana, CA 92702 Tel: 714-664-0159 Fax: 714-664-0596

Exhibit 3D-Contractor Documentation

Item B.18 – ADDITIONAL CONTRACTOR COMMITMENTS

This item consists of 2 pages (including this page).

Ware Disposal Inc. made no additional contractor commitments as part of its response to IFB 2018 GDD 017.

Ware Disposal Inc.

Lennox GDD

Exhibit 3D-Contractor Documentation

Item B.19 – TRANSITION ROLL-OUT PLAN

This item consists of 3 pages (including this page).

Item B.19 – TRANSITION ROLL-OUT PLAN

MILESTONE CHART AND SCHEDULE

MILESTONE	DESCRIPTION
9 May 2018	Submission of Ware Disposal's proposal.
30 May 2018	First transition meeting with LADPW staff.
20 June 2018	Submittal of required insurance to the County of Los Angeles (APPROVED)
20 June 2018	Submittal of required performance assurance to the County of Los Angeles (APPROVED)
29 June 2018	Submittal of Exhibit 3D Documentation to LADPW Staff for Review (APPROVED)
3 July 2018	Los Angeles County Board of Supervisors Award Contract.
12 July 2018	Sign and execute purchase agreement with CDS for carts and bins and provide LADPW with a copy for inclusion in the Exhibit 3D Documents
13 July 2018 and 16 July 2018, respectively	Initial mailings sent to Lennox GDD residents on the following subject matters: <ul style="list-style-type: none"> • Welcome letter • FY 2019 subscription notice • Revised recycling guide Proof of mailing provided to LADPW staff regarding both.
16 July 2018	Finalize (a) Exhibit 3D Documentation, (b) Public Education Materials for dissemination to County GDD residents and (c) Residential Routes for County GDD.
26 and 28 July 2018	WDCO conducts the required community meetings as part of the transition from existing service provider to new service provider.
23 July 2018	Commence training of customer service staff as it relates to residential program's contents and highlights, including hiring of new customer service representatives in appropriate languages as determined collectively.
30 July 2018	Public education and outreach brochures, mailers and initial vehicle billboard material completed and ready for distribution by this date (WDCO to utilize a Mailing House, then the USPS for initial mailings to Lennox GDD Franchise area residents).
Week of 30 July 2018	Execute the final GDD agreement between County and WDCO. By said date, WDCO has already provided and secured approval of (a) the required insurance certificate and (b) the performance assurance document.
13 August 2018	COMMENCEMENT OF NEW TRASH AND RECYCLING SERVICES Collection of residential old or broken carts (if necessary and/or required)—to run through 28 September 2018
13 August 2018 Week of 13 August 2018	Respond to resident inquiries on the service, service dates, or alleged missed pick-ups.
13 August 2018 Week of 13 August 2018 27 August 2018	Conduct field screening surveys to assure proper routing and service levels; provide trouble shooting assistance to residents and other customers. Commencement of provision of weekly telephone call log matrix to LADPW Staff as part of the collaborative process

	WDCO to submit draft Fall 2018 newsletter to LADPW staff for review and comment. Newsletter to advertise either (a) the annual clean up campaign event and/or (b) the compost and mulch giveaway event as directed by LADPW staff.
3 September 2018	LABOUR DAY HOLIDAY—NO SERVICE PROVIDED ON MONDAY. SERVICE DELAYED ONE DAY FOR THE ENTIRE WEEK.
10 September 2018	LADPW staff to provide WDCO with approved Fall 2018 newsletter for distribution the week of 17 September 2018.
Week of 17 September 2018	WDCO distribution of Q3 CY 2018 invoices to Lennox GDD residents.
By 28 September 2018	First WDCO submittal of the required Lennox GDD community <ul style="list-style-type: none"> a. SWIMS Form C Residential b. SWIMS Form L Residential SWIMS Form T Task 2
28 September 2018	WDCO to present a final transition report to LADPW staff if so requested.
By 15 November 2018	<ul style="list-style-type: none"> c. First WDCO submittal of the required (a) Lennox GDD Q3 CY 2018 quarterly report and (b) Lennox GDD Q3 CY 2018 bill list Form P to SWIMS.
By 15 November 2018	WDCO to report to LADPW the results of the Q3 CY 2018 Lennox GDD community clean up event (if held).
22 November 2018	THANKSGIVING DAY HOLIDAY—NO SERVICE PROVIDED ON THURSDAY SERVICE DELAYED ONE DAY FOR THE ENTIRE WEEK.
25 December 2018	CHRISTMAS DAY HOLIDAY—NO SERVICE PROVIDED ON TUESDAY SERVICE DELAYED ONE DAY FOR THE ENTIRE WEEK.
26 December 2018	WDCO to commence Christmas tree collection service to the Lennox GDD community.
29 December 2018	WDCO first full quarter of provision of service to the Lennox GDD community.
1 January 2019	NEW YEAR'S DAY HOLIDAY—NO SERVICE PROVIDED ON TUESDAY SERVICE DELAYED ONE DAY FOR THE ENTIRE WEEK.
April 2019 DATE TBD	WDCO to conduct the first Compost and Mulch Giveaway Event. Preferred location is Lennox Park, Lennox, California.

Exhibit 3D-Contractor Documentation

Item B.20 – DIFFICULT TO SERVICE OCCUPANTS

This item consists of 2 pages (including this page).

Item B.20 – DIFFICULT TO SERVICE OCCUPANTS

In the event Ware Disposal Inc. encounters difficult to service occupants, Ware Disposal Inc. will work with individual clients to determine the appropriate point of collection at their premises. Additionally, Ware Disposal Inc. will work with clients on the best location to place containers for collection purposes. If this requires Ware Disposal Inc. to provide scout service to certain clients, then Ware Disposal Inc. will provide that to clients in the Lennox Garbage Disposal District.

As it relates to vehicles, Ware Disposal Inc. utilizes the service of a burro collection vehicle for some difficult to service occupants. Said vehicles have been included as part of the Exhibit 3D documentation for the Lennox Garbage Disposal District.

Exhibit 3D-Contractor Documentation

Item B.21 – MOVEMENT OF GREEN WASTE

This item consists of 8 pages (including this page).

Ware Disposal Inc. will comply with the California Department of Food and Agriculture's quarantine restrictions for the movement of green waste.

Please see Item A.1 for a copy of the CDFA agreement in this matter.

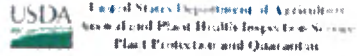

COOPERATIVE ASIAN CITRUS PSYLLID AND HUANGLONGBING QUARANTINE PROGRAM COMPLIANCE AGREEMENT

Orange County Agricultural Commissioner / CDFA / USDA

Pursuant to California Food and Agriculture Codes 5701-5705, California Code of Regulations 3435, 3439, and 3154 and the Federal Domestic Quarantine Order, Citrus Greening Disease and Asian Citrus Psyllid and Master Permits QC1386, QC1464, and QC1480

Orange County Agricultural Commissioner's Office
 Street Address: 222 E Bristol Lane
Orange, CA 92865
 Phone: (714) 955-0100
 Fax: (714) 921-2713
 Contact: Rebekah Ban

Compliance Agreement Number: 30-CITRUS-0021

Establishment Name:	WARE DISPOSAL INC				
Owner / Manager Name:	JAY WARE				
Mailing Address:	PO BOX 1318	City:	SANTA ANA	Zip:	92702 1318
Physical Address:	1451 MANHATTAN AVENUE	City:	FULLERTON	Zip:	92831 5221
Phone:	(714) 654 - 0677	E-Mail:	jason@waredisposal.com		
Cross Street:	Manhattan and Burton, Fullerton	Lat/Long:	33 855119, -117 902839		

Program:

The County Agricultural Commissioner, the California Department of Food and Agriculture (CDFA), and the United States Department of Agriculture (USDA), cooperating as the Asian Citrus Psyllid and Huanglongbing Disease Quarantine Program

Business/Establishment:

Establishment Name (subsequently referred to as "Establishment")

WARE DISPOSAL INC

Background:

The pests known as Asian citrus psyllid (ACP) and Huanglongbing (HLB) present a real and ongoing threat to the agricultural industry, environment and economy of the State of California. Movement of regulated articles and commodities is a recognized channel for the spread of ACP and HLB from established areas to new locations. The ACP and HLB Quarantine Program is a cooperative effort between public entities that are responsible for mitigating the movement of ACP from regulated areas where the pest is established to new locations. The list of regulated articles and commodities can be found here: <http://ohpns.cdfa.ca.gov/PE/interior/Excludes/owod/acpexcludr.pdf>

AGREEMENT:

A. The Asian Citrus Psyllid and Huanglongbing Quarantine Program, hereafter referred to as the Program, will permit your establishment to self-execute the Asian Citrus Psyllid and Huanglongbing quarantine requirements attached as exhibits checked below, inclusive and incorporated into this agreement by reference as if fully set out. The exhibits checked below are binding:

Check all that apply.

<input type="checkbox"/>	Exhibit ACP Citrus-G	Grower / Grove Manager
<input type="checkbox"/>	Exhibit ACP Citrus-PH	Citrus Packer / Citrus Juicer/ Citrus Processor
<input checked="" type="checkbox"/>	Exhibit ACP Citrus-I	Transporter / Hauler - Citrus Fruit
<input type="checkbox"/>	Exhibit 1386-G	Grower / Grove Manager - Mandarins with Stems and Leaves
<input type="checkbox"/>	Exhibit 1386-PH	Packer / Processor - Mandarins with Stems and Leaves
<input checked="" type="checkbox"/>	Exhibit 1386-T	Transporter / Hauler - Mandarins with Stems and Leaves
<input type="checkbox"/>	Exhibit 1480-G	Grower / Grove Manager in an HLB Quarantine Area
<input type="checkbox"/>	Exhibit 1480-PH	Packer / Processor - Citrus Fruit Grown in an HLB Quarantine Area
<input type="checkbox"/>	Exhibit X1	Program Management Practices for Aerial Spray Treatments
<input type="checkbox"/>	Exhibit X2	Program Management Practices for Ground Spray and Drone Treatments
<input type="checkbox"/>	Exhibit X3	Program Management Practices for Hazardous Materials Spills

B. In exchange for the Program's promise contained in sub-paragraph "A" above, the Establishment agrees to abide by the following rules and regulations:

1. Handle, process, and/or move regulated articles in accordance with the Asian Citrus Psyllid and Huanglongbing quarantine requirements;
2. Follow the Program's instructions regarding the use of all permits and certificates;
3. Maintain and make such records, as the Program requires, accessible for inspection upon reasonable notice by the Program Officer. These records shall be maintained for a period of the later of 2 years or the resolution of any outstanding claims.

C. This agreement becomes effective on signing and shall remain in effect until canceled by either party on 30 days notice to the other at the address of either appearing above. However, the Program may accelerate the notice to immediate for cause, including but not limited to the Establishment's abandonment of the procedures outlined in the attached Exhibit(s).

D. Establishment assumes liability if any, arising from the manner in which Establishment sells, handles or distributes any regulated host material.

NOTICE: Any signatory or employee of any signatory who violates the terms of this Compliance Agreement may be subject to civil penalties pursuant to California Food and Agricultural Code Section 5705.

Signed in the County of <u>Orange</u> in the State of California on <u>02</u> / <u>27</u> / <u>2018</u>	
Establishment Manager/Owner	Program Officer
Print Name: JAY WARE	Print Name: <i>Jennifer VanDyke</i>
Signature: <i>Jay Ware</i>	Signature: <i>Jennifer VanDyke</i>



Compliance Agreement # 30-CITRUS-001

**EXHIBIT: ACP CITRUS – T
TRANSPORTER / HAULER**

**PROVISIONS FOR THE INTRASTATE MOVEMENT OF BULK CITRUS FRUIT
FROM OR WITHIN AN ASIAN CITRUS PSYLLID BULK CITRUS REGIONAL QUARANTINE ZONE**

To Be Used in Conjunction with QC Permit 1464

Establishment agrees to the following:

1. **Establishments Under Compliance**
 - a Only transport shipments from a Grower/Grove Manager operating under compliance with the ACP Program.
 - b Only transport shipments to a Packer/Juicer/Other Processor operating under compliance with the Program.

Establishments operating under compliance can be verified online at:
https://www.cdfa.ca.gov/plant/accproq_establishments.html

2. **Safeguarding**

All shipments of citrus fruit shall be safeguarded the entire time while in transit, beginning before the vehicle departs the loading site and until it reaches final destination for offloading. Any screen mesh used as an ACP-proof barrier shall be 0.3 square millimeters (e.g. 0.547 x 0.547, or 0.5 x 0.6) or less in size. Approved safeguarding measures include the following:

 - a. Citrus fruit is transported in a fully enclosed vehicle, or
 - b. Transporting vehicles which have solid wall construction on sides and rear; a solid tarpaulin or ACP-proof barrier shall cover the top. The tarp or ACP-proof barriers shall be in good repair without tears or holes and be securely fastened to the solid walls of the truck, ensuring no gaps are present and in a manner that would prevent exposure to ACP or the loss of fruit, leaves, stems, branches, and plant debris while in transit, or
 - c. Transporting vehicles constructed of wire mesh or expanded metal shall be completely covered with a solid tarp or ACP-proof barriers that extend down to the truck bed, ensuring no gaps are present. The tarp or ACP-proof barrier shall be in good repair without tears or holes and be securely fastened to the bed of the truck in a manner that would prevent exposure to ACP or the loss of fruit, leaves, stems, branches, and plant debris while in transit, or
 - d. Transporting vehicles which have a flatbed trailer with field pallets or bins shall be entirely covered to the bed of the truck with a solid tarp or ACP-proof barrier. The tarp or screen mesh shall be in good repair without tears or holes and be securely fastened to the bed of the truck, ensuring no gaps are present around the bins, and in a manner that would prevent exposure to ACP or the loss of fruit, leaves, stems, branches, and plant debris while in transit, or
 - e. Any other Program approved manner specified in the "Special Instructions."
3. **Transporter Cleanliness**

The vehicle and/or trailer used for transporting the shipment must be free of all leaf and stem debris and free of all life stages of ACP prior to transport and after delivery.
4. **Evidence of Compliance**

Place a copy of the compliance agreement, this exhibit, and the applicable "ACP-Free Declaration" form in each transport vehicle.
5. **Direct Route**

Take the most continuous, direct route, without interruption to a Program approved receiver.
6. **Green Waste Disposal**

All green waste, including leaf and stem debris, must be continuously collected, safeguarded, and disposed of in accordance with the Program, local County Agricultural Commissioner, under QC Master Permit 1289 or other Program approved manner.

12/27/2017

Page 1 of 2

- 7. **Records**
Maintain records of all ACP host shipments for a minimum of two years and make such records available to Program officials immediately upon request.
- 8. **Training**
Ensure all employees receive training to be compliant with all specifications of the compliance agreement and this exhibit.
- 9. **Spill Notification**
Notify the Program as soon as possible and no later than 24 hours after spillage of any shipment.
- 10. **Vehicle Tracking System**
List all truck and trailer license plates below. The Establishment shall update the Program immediately any time license plates are added, changed, or are no longer in use. If more space is needed, continue on back of this exhibit or attach pages as needed.
- 11. **Violation**
Violation of any terms of the compliance agreement or this exhibit shall result in the suspension of the compliance agreement until an investigation is completed and for a minimum period of two weeks.

Transporter License Plates Will be provided once vehicles have been procured.

1		11	
2		12	
3		13	
4		14	
5		15	
6		16	
7		17	
8		18	
9		19	
10		20	

SPECIAL INSTRUCTIONS:

JAY WARE, Ware Disposal Inc.
Printed name (Owner/Manager)



Signature of Establishment

27 February 2018
Date

Failure to comply with any stipulation outlined above may result in civil penalties pursuant to California Food and Agricultural Code Section 5705 and/or revocation of this Agreement.

12/27/2017

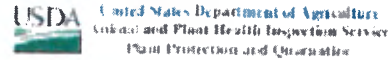
Page 2 of 2



Compliance Agreement # 30-CITRUS-0021

**EXHIBIT 1386-T
TRANSPORTER/HAULER
OF MANDARINS WITH STEMS AND LEAVES**

**PROVISIONS FOR THE INTRASTATE MOVEMENT OF MANDARINS WITH ATTACHED STEMS AND/OR LEAVES
FROM OR WITHIN AN ASIAN CITRUS PSYLLID BULK CITRUS REGIONAL QUARANTINE ZONE**

To Be Used in Conjunction with Master Permit QC 1386

Establishment agrees to the following:

1. Establishments Under Compliance

- a. Ensure that mandarin fruit with attached stems and leaves being transported is produced by a grower/grove manager under compliance with the ACP Program
 - i. Mandarins with stems and leaves must not originate or be processed in an area quarantined for Huanglongbing (HLB) or regulated for sweet orange scab (SOS); and
 - ii. The fruit must not be commingled with fruit that has been in an area quarantined for HLB or regulated for SOS.
- b. Ensure fruit is delivered to and handled by packers/processors under compliance with the Program. Establishments operating under compliance can be verified online at https://www.cdfa.ca.gov/plan/acpreq_establishments.html

2. Safeguarding

All shipments of mandarin fruit with attached stems and leaves must be safeguarded the entire time while in transit beginning before the vehicle departs the loading site and until it reaches final destination for offloading. Any screen mesh used as an ACP-proof barrier shall be 0.3 square millimeters (e.g. 0.547 x 0.547, or 0.5 x 0.6) or less in size. Approved safeguarding measures include the following:

- a. Mandarin fruit is transported in a fully enclosed vehicle, or
- b. Transporting vehicles which have solid wall construction on sides and rear, a solid tarpaulin or ACP-proof barrier shall cover the top. The tarp or ACP-proof barriers shall be in good repair without tears or holes and be securely fastened to the solid walls of the truck, ensuring no gaps are present and in a manner that would prevent exposure to ACP or the loss of fruit, leaves, stems, branches, and plant debris while in transit, or
- c. Transporting vehicles constructed of wire mesh or expanded metal shall be completely covered with a solid tarp or ACP-proof barriers that extend down to the truck bed, ensuring no gaps are present. The tarp or ACP-proof barrier shall be in good repair without tears or holes and be securely fastened to the bed of the truck in a manner that would prevent exposure to ACP or the loss of fruit, leaves, stems, branches, and plant debris while in transit, or
- d. Transporting vehicles which have a flatbed trailer with field pallets or bins shall be entirely covered to the bed of the truck with a solid tarp or ACP-proof barrier. The tarp or screen mesh shall be in good repair without tears or holes and be securely fastened to the bed of the truck, ensuring no gaps are present around the bins, and in a manner that would prevent exposure to ACP or the loss of fruit, leaves, stems, branches, and plant debris while in transit, or
- e. Any other Program approved manner specified in the "Special Instructions"

3. Transporter Cleanliness

The vehicle and/or trailer used for transporting the shipment must be free of all leaf and stem debris and free of all life stages of ACP prior to transport and after delivery.

4. Evidence of Compliance

Place a copy of the compliance agreement, this exhibit, and the applicable "ACP-Free Declaration" form in each transport vehicle

12/27/2017

Page 1 of 2



5. **Direct Route**
Take the most continuous, direct route, without interruption to a Program approved receiver
6. **Green Waste Disposal**
All green waste, including leaf and stem debris, shall be continuously collected, safeguarded and disposed of in accordance with the Program, local County Agricultural Commissioner, under QC Master Permit 1289 or other Program approved manner
7. **Records**
Maintain records of all ACP host shipments for a minimum of two years and make such records available to Program officials immediately upon request.
8. **Training**
Ensure all employees receive training to be compliant with all specifications of the compliance agreement and this exhibit.
9. **Spill Notification**
Notify the Program as soon as possible and no later than 24 hours after spillage of any shipment.
10. **Vehicle Tracking System**
List all truck and trailer license plates below. Update the Program immediately any time license plates are added, changed, or are no longer in use. If more space is needed, continue on the back of this exhibit or attach pages as necessary.
11. **Violation**
Violation of any terms of the compliance agreement or this exhibit shall result in the suspension of the compliance agreement until an investigation is completed and for a minimum period of two weeks.

Transporter License Plates Will be provided once vehicles have been procured

1		8	
2		9	
3		10	
4		11	
5		12	
6		13	
7		14	

SPECIAL INSTRUCTIONS: _____

JAY WARE Ware Disposal Inc
Printed name (Owner/Manager)

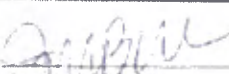
Signature of Establishment

27 February 2018
Date

Failure to comply with any stipulation outlined above may result in civil penalties pursuant to California Food and Agricultural Code Section 5700 and/or revocation of this Agreement

EXHIBIT 5 – Additional Contract Language

PART 1 - Part no longer used.

PART 2 - Part no longer used.

PART 3 - GENERAL CONTRACT REQUIREMENTS

A. Employment Eligibility Verification

- 1.** CONTRACTOR warrants that it fully complies with all Federal and State statutes and regulations regarding the employment of aliens and others and that all its employees performing work under this CONTRACT meet the citizenship or alien status requirements set forth in Federal and State statutes and regulations. CONTRACTOR shall obtain, from all covered employees performing services hereunder, all verification and other documentation of employment eligibility status required by Federal and State statutes and regulations including, but not limited to, the Immigration Reform and Control Act of 1986 (P.L. 99-603), or as they currently exist and as they may be hereafter amended. CONTRACTOR shall retain all such documentation for all covered employees for the period prescribed by law.
- 2.** CONTRACTOR shall defend and hold harmless, COUNTY of Los Angeles, its Special Districts, Elected Officials, Officers, Agents, Employees, and Volunteers sanctions and any other liability which may be assessed against CONTRACTOR or COUNTY or both about any alleged violation of Federal or State statutes or regulations pertaining to the eligibility for employment of Persons performing services under this CONTRACT.

B. Security and Background Investigations

Security and background investigations of CONTRACTOR's staff may be required at the discretion of COUNTY as a condition of beginning and continuing work under any resulting CONTRACT. The cost of background checks is the responsibility of CONTRACTOR.

C. Consideration of Hiring COUNTY Employees

Should CONTRACTOR require additional or replacement personnel after the effective date of this CONTRACT to perform the services set forth herein, CONTRACTOR shall give first consideration for such employment openings to qualified permanent COUNTY employees who are targeted for layoff or qualified, former COUNTY employees who are on a reemployment list during the life of this CONTRACT.

D. Conflict of Interest

No COUNTY employee whose position with COUNTY enables such employee to influence the award of this CONTRACT or any competing contract, and no spouse or economic dependent of such employee shall be employed in any capacity by CONTRACTOR or have any other direct or indirect financial interest in this CONTRACT. No officer or employee of CONTRACTOR who may financially benefit from the performance of the work hereunder shall in any way participate in COUNTY's approval, or ongoing evaluation, of such work, or in any way attempt to unlawfully influence COUNTY's approval or ongoing evaluation of such work.

CONTRACTOR represents and warrants that it is aware of, and its authorized officers have read, the provisions of County Code, Section 2.180.010, "Certain Contracts Prohibited," and that execution of this CONTRACT will not violate those provisions. CONTRACTOR shall comply with all conflict of interest laws, ordinances, and regulations now in effect or hereafter to be enacted during the Term of this CONTRACT. CONTRACTOR warrants that it is not now aware of any facts that create a conflict of interest. If CONTRACTOR hereafter becomes aware of any facts that might reasonably be expected to create a conflict of interest, it shall immediately make full written disclosure of such facts to COUNTY. Full written disclosure shall include, but is not limited to, identification of all Persons implicated and a complete description of all relevant circumstances. Failure to comply with the provisions of this paragraph shall be a material breach of this CONTRACT subjecting CONTRACTOR to either contract termination for default or debarment proceedings or both. CONTRACTOR must sign and adhere to the "Conflict of Interest Certification" (Form PW-5).

E. Fair Labor Standards Act

CONTRACTOR shall comply with all applicable provisions of the Federal Fair Labor Standards Act and shall indemnify, defend, and hold harmless COUNTY, its Special Districts, Elected Officials, Officers, Agents, Employees, and Volunteers from all liability, including, but not limited to, wages, overtime pay, liquidated damages, penalties, court costs, and attorneys' fees arising under any wage and hour law, including the Federal Fair Labor Standards Act, for work performed by CONTRACTOR's employees for which COUNTY may be found jointly or solely liable.

F. Record Retention and Inspection/Audit Settlement

CONTRACTOR shall maintain accurate and complete financial Records of its activities and operations relating to this CONTRACT in accordance with generally accepted accounting principles. CONTRACTOR shall also maintain accurate and complete employment and other Records relating to its performance of this CONTRACT. CONTRACTOR agrees that COUNTY, or its authorized representatives, shall have access to and the right to examine, audit, review Records, excerpt, copy, or transcribe any pertinent transaction, activity, or record

relating to this CONTRACT. All such material, including, but not limited to, all financial Records, bank statements, cancelled checks, or other proof of payment, timecards, sign-in/sign-out sheets, and other time and employment Records, and proprietary data and information, shall be kept and maintained by CONTRACTOR and shall be made available to COUNTY during the Term of this CONTRACT and for a period of five years thereafter unless COUNTY's written permission is given to Dispose of any such material prior to such time. All such material shall be maintained by CONTRACTOR at a location in COUNTY, provided that if any such material is located outside COUNTY, then, at COUNTY's option, CONTRACTOR shall pay COUNTY for travel, per diem, and other costs incurred by COUNTY to examine, audit, review Records, excerpt, copy, or transcribe such material at such other location.

1. If a review of Records of CONTRACTOR is conducted specifically regarding this CONTRACT by any Federal or State auditor, or by any auditor, reviewer, or accountant employed by CONTRACTOR or otherwise, then CONTRACTOR shall file a copy of such review of Records Report with COUNTY's Auditor-Controller within 30 days of CONTRACTOR's receipt thereof, unless otherwise provided by applicable Federal or State law or under this CONTRACT. Subject to applicable law, COUNTY shall make a reasonable effort to maintain the confidentiality of such review of Records Report (s).
2. Failure on the part of CONTRACTOR to comply with any of the provisions of this paragraph shall constitute a material breach of this CONTRACT upon which COUNTY may suspend or terminate for default or suspend this CONTRACT.
3. If, at any time during the Term of this CONTRACT or within five years after the expiration or termination of this CONTRACT, representatives of COUNTY conduct a review of Records of CONTRACTOR regarding the work performed under this CONTRACT, and if such review of Records finds that COUNTY's dollar liability for any such work is less than payments made by COUNTY to CONTRACTOR, then the difference shall be either: a) repaid by CONTRACTOR to COUNTY by cash payment upon demand or b) at the sole option of COUNTY's Auditor-Controller, deducted from any amounts due to CONTRACTOR from COUNTY, whether under this CONTRACT or otherwise. If such review of Records finds that COUNTY's dollar liability for such work is more than the payments made by COUNTY to CONTRACTOR, then the difference shall be paid to CONTRACTOR by COUNTY by cash payment, provided that in no event shall COUNTY's maximum obligation for this CONTRACT exceed the funds appropriated by COUNTY for this CONTRACT.

G. Compliance with COUNTY's Jury Service Program

1. Jury Service Program

This CONTRACT is subject to the provisions of COUNTY's ordinance entitled CONTRACTOR Employee Jury Service (Jury Service Program) as codified in Sections 2.203.010 through 2.203.090 of County Code.

2. Written Employee Jury Service Policy

- a. Unless CONTRACTOR has demonstrated to COUNTY's satisfaction either that CONTRACTOR is not a "CONTRACTOR" as defined under the Jury Service Program (Section 2.203.020 of County Code) or that CONTRACTOR qualifies for an exception to the Jury Service Program (Section 2.203.070 of County Code), CONTRACTOR shall have and adhere to a written policy that provides that its Employees shall receive from CONTRACTOR, on an annual basis, no less than five days of regular pay for actual jury service. The policy may provide that Employee deposit any fees received for such jury service with CONTRACTOR or that CONTRACTOR deduct from the Employee's regular pay the fees received for jury service.
- b. For purposes of this Section, "CONTRACTOR" means a Person, partnership, corporation, or other entity which has a contract with COUNTY or a subcontract with a COUNTY contractor and has received or will receive an aggregate sum of \$50,000 or more in any 12-month period under one or more COUNTY contracts or subcontracts. "Employee" means any California resident who is a full-time employee of CONTRACTOR. "Full-time" means 40 hours or more worked per week, or a lesser number of hours if: 1) the lesser number is a recognized industry standard as determined by COUNTY, or 2) CONTRACTOR has a long-standing practice that defines the lesser number of hours as full-time. Full-time employees providing short-term, temporary services of 90 days or less within a 12-month period are not considered full-time for purposes of the Jury Service Program. If CONTRACTOR uses any Subcontractor to perform services for COUNTY under this CONTRACT, the Subcontractor shall also be subject to the provisions of this Section. The provisions of this Section shall be inserted into any such subcontract CONTRACT and a copy of the Jury Service Program shall be attached to the CONTRACT.
- c. If CONTRACTOR is not required to comply with the Jury Service Program when this CONTRACT commences, CONTRACTOR shall have a continuing obligation to review the applicability of its "exception status" from the Jury Service Program, and CONTRACTOR shall immediately notify COUNTY if CONTRACTOR

at any time either comes within the Jury Service Program's definition of "CONTRACTOR" or if CONTRACTOR no longer qualifies for an exception to the Jury Service Program. In either event, CONTRACTOR shall immediately implement a written policy consistent with the Jury Service Program. COUNTY may also require, at any time during this CONTRACT and at its sole discretion, that CONTRACTOR demonstrate to COUNTY's satisfaction that CONTRACTOR either continues to remain outside of the Jury Service Program's definition of "CONTRACTOR" and/or that CONTRACTOR continues to qualify for an exception to the Jury Service Program.

- d. CONTRACTOR's violation of this Section of this CONTRACT may constitute a material breach of this CONTRACT. In the event of such material breach, COUNTY may, in its sole discretion, suspend or terminate this CONTRACT and/or bar CONTRACTOR from the award of future COUNTY contracts for a period consistent with the seriousness of the breach.

H. CONTRACTOR's Charitable Activities Compliance

The Supervision of Trustees and Fundraisers for Charitable Purposes Act regulates entities receiving or raising charitable contributions. The "Nonprofit Integrity Act of 2004" (SB 1262, Chapter 919) increased Charitable Purposes Act requirements. By requiring CONTRACTOR's to complete the Charitable Contributions Certification (Form PW-12), COUNTY seeks to ensure that all COUNTY CONTRACTOR's which receive or raise charitable contributions comply with California law to protect COUNTY and its taxpayers. A CONTRACTOR which receives or raises charitable contributions without complying with its obligations under California law commits a material breach subjecting it to either contract termination for default or debarment proceedings or both. (County Code Chapter 2.202)

I. Social Enterprise Preference Program

This CONTRACT is subject to the provisions of COUNTY's ordinance entitled Social Enterprise (SE) Preference Program, as codified in Chapter 2.205 of County Code.

CONTRACTOR shall not knowingly and with the intent to defraud, fraudulently obtain, retain, attempt to obtain or retain, or aid another in fraudulently obtaining or retaining or attempting to obtain or retain certification as a SE.

CONTRACTOR shall not willfully and knowingly make a false statement with the intent to defraud, whether by affidavit, Report, or other representation, to a COUNTY official or employee for the purpose of influencing the certification or denial of certification of any entity as a SE.

If CONTRACTOR has obtained COUNTY certification as a SE by reason of having furnished incorrect supporting information or by reason of having withheld information, and which knew, or should have known, the information furnished was incorrect or the information withheld was relevant to its request for certification, and which by reason of such certification has been awarded this contract to which it would not otherwise have been entitled, CONTRACTOR shall:

- Pay to COUNTY any difference between the CONTRACT amount and what COUNTY's costs would have been if the CONTRACT had been properly awarded.
- In addition to the amount described in subdivision (1), be assessed a penalty in the amount of not more than ten percent of the amount of this Contract.
- Be subject to the provisions of Chapter 2.202 of County Code (Determinations of CONTRACTOR Nonresponsibility and CONTRACTOR Debarment).

The above penalties shall also apply to any entity that has previously obtained proper certification, however, as a result of a change in their status would no longer be eligible for certification and fails to notify the Department of Consumer and Business Affairs of this information prior to responding to a solicitation or accepting a contract award.

J. Local Small Business Enterprise Preference Program

This CONTRACT is subject to the provisions of COUNTY's ordinance entitled Local Small Business Enterprise Preference Program, as codified in Chapter 2.204 of County Code.

CONTRACTOR shall not knowingly and with the intent to defraud, fraudulently obtain, retain, attempt to obtain or retain, or aid another in fraudulently obtaining or retaining or attempting to obtain or retain certification as a Local Small Business Enterprise.

CONTRACTOR shall not willfully and knowingly make a false statement with the intent to defraud, whether by affidavit, Report, or other representation, to a COUNTY official or employee for the purpose of influencing the certification or denial of certification of any entity as a Local Small Business Enterprise.

If CONTRACTOR has obtained COUNTY certification as a Local Small Business Enterprise by reason of having furnished incorrect supporting information or by reason of having withheld information, and which knew, or should have known, the information furnished was incorrect or the information withheld was relevant to its request for certification, and which by reason of such certification has been awarded this CONTRACT to which it would not otherwise have been entitled, shall:

- Pay to COUNTY any difference between this CONTRACT amount and what COUNTY's costs would have been if this CONTRACT had been properly awarded.
- In addition to the amount described in subdivision (1), be assessed a penalty in an amount of not more than ten percent of the amount of this CONTRACT.
- Be subject to the provisions of Chapter 2.202 of County Code (Determinations of CONTRACTOR Nonresponsibility and CONTRACTOR Debarment).

The above penalties shall also apply to any business that has previously obtained proper certification, however, as a result of a change in their status would no longer be eligible for certification and fails to notify the State and the Department of Consumer and Business Affairs of this information prior to responding to a solicitation or accepting a contract award.

K. Disabled Veteran Enterprise Preference Program

This CONTRACT is subject to the provisions of COUNTY's ordinance entitled Disabled Veteran Business Enterprise (DVBE) Preference Program, as codified in Chapter 2.211 of County Code.

CONTRACTOR shall not knowingly and with the intent to defraud, fraudulently obtain, retain, attempt to obtain or retain, or aid another in fraudulently obtaining or retaining or attempting to obtain or retain certification as a DVBE.

CONTRACTOR shall not willfully and knowingly make a false statement with the intent to defraud, whether by affidavit, Report, or other representation, to a COUNTY official or employee for the purpose of influencing the certification or denial of certification of any entity as a DVBE.

If CONTRACTOR has obtained certification as a DVBE by reason of having furnished incorrect supporting information or by reason of having withheld information, and which knew, or should have known, the information furnished was incorrect or the information withheld was relevant to its request for certification, and which by reason of such certification has been awarded this contract to which it would not otherwise have been entitled, shall:

- Pay to COUNTY any difference between the CONTRACT amount and what COUNTY's costs would have been if the CONTRACT had been properly awarded.
- In addition to the amount described in subdivision (1), be assessed a penalty in an amount of not more than ten percent of the amount of the CONTRACT.
- Be subject to the provisions of Chapter 2.202 of County Code (Determinations of CONTRACTOR Nonresponsibility and CONTRACTOR Debarment).

Notwithstanding any other remedies in this contract, the above penalties shall also apply to any business that has previously obtained proper certification, however, as a result of a change in their status would no longer be eligible for certification and fails to notify the State and the Department of Consumer and Business Affairs of this information prior to responding to a solicitation or accepting a contract award.

L. **CONTRACTOR Responsibility and Debarment**

1. **Responsible CONTRACTOR**

A responsible CONTRACTOR is a contractor who has demonstrated the attribute of trustworthiness as well as quality, fitness, capacity, and experience to satisfactorily perform the CONTRACT. It is COUNTY's policy to conduct business only with responsible contractors.

2. **Chapter 2.202 of County Code**

CONTRACTOR is hereby notified that, in accordance with Chapter 2.202 of County Code, if COUNTY acquires information concerning the performance of CONTRACTOR on this or other contracts which indicates that CONTRACTOR is not responsible, COUNTY may, in addition to other remedies provided in this CONTRACT, debar CONTRACTOR from bidding or proposing on, being awarded, and/or performing work on COUNTY contracts for a specified period of time, which generally will not exceed 5 years but may exceed 5 years or be permanent if warranted by the circumstances, and suspend or terminate any or all existing contracts CONTRACTOR may have with COUNTY.

3. **Nonresponsible CONTRACTOR**

COUNTY may debar a CONTRACTOR if the Board finds, in its discretion, that CONTRACTOR has done any of the following: (1) violated any Term of a contract with COUNTY or a nonprofit corporation created by COUNTY; (2) committed an act or omission which negatively reflects on CONTRACTOR's quality, fitness, or capacity to perform a contract with COUNTY, any other public entity, or a nonprofit corporation created by COUNTY, or engaged in a pattern or practice which negatively reflects on same; (3) committed an act or offense which indicates a lack of business integrity or business honesty; or (4) made or submitted a false claim against COUNTY or any other public entity.

4. **Contractor Hearing Board**

- a. If there is evidence that CONTRACTOR may be subject to debarment, Public Works will notify CONTRACTOR in writing of the evidence which is the basis for the proposed debarment and will

advise CONTRACTOR of the scheduled date for a debarment hearing before Contractor Hearing Board.

- b. Contractor Hearing Board will conduct a hearing where evidence on the proposed debarment is presented. CONTRACTOR and/or CONTRACTOR's representative shall be given an opportunity to submit evidence at that hearing. After the hearing, Contractor Hearing Board will prepare a tentative proposed decision, which shall contain a recommendation regarding whether CONTRACTOR should be debarred, and, if so, the appropriate length of time of the debarment. CONTRACTOR and Public Works shall be provided an opportunity to object to the tentative proposed decision prior to its presentation to the Board of Supervisors.
- c. After consideration of any objections, or if no objections are submitted, a record of the hearing, the proposed decision, and any other recommendation of Contractor Hearing Board shall be presented to the Board. The Board of Supervisors shall have the right to modify, deny, or adopt the proposed decision and recommendation of Contractor Hearing Board.
- d. If a CONTRACTOR has been debarred for a period longer than five years, that CONTRACTOR may, after the debarment has been in effect for at least five years, submit a written request for review of the debarment determination to reduce the period of debarment or terminate the debarment. COUNTY may, in its discretion, reduce the period of debarment or terminate the debarment if it finds that CONTRACTOR has adequately demonstrated one or more of the following: (1) elimination of the grounds for which the debarment was imposed; (2) a bona fide change in ownership or management; (3) material evidence discovered after debarment was imposed; or (4) any other reason that is in the best interests of COUNTY.
- e. Contractor Hearing Board will consider a request for review of a debarment determination only where (1) CONTRACTOR has been debarred for a period longer than five years; (2) the debarment has been in effect for at least five years; and (3) the request is in writing, states one or more of the grounds for reduction of the debarment period or termination of the debarment, and includes supporting documentation. Upon receiving an appropriate request, Contractor Hearing Board will provide Notice of the hearing on the request. At the hearing, Contractor Hearing Board shall conduct a hearing where evidence on the proposed reduction of debarment period or termination of debarment is presented. This hearing shall be conducted and the request for review decided by Contractor Hearing Board pursuant to the same procedure as for a debarment hearing.

- f. Contractor Hearing Board's proposed decision shall contain a recommendation on the request to reduce the period of debarment or terminate the debarment. Contractor Hearing Board shall present its proposed decision and recommendation to the Board of Supervisors. The Board of Supervisors shall have the right to modify, deny, or adopt the proposed decision and recommendation of Contractor Hearing Board.

5. Subcontractors of CONTRACTOR

These terms shall also apply to Subcontractors of COUNTY CONTRACTORS.

M. Reporting Requirements for Improper Solicitations

CONTRACTOR shall immediately report any attempt by a COUNTY officer or employee to solicit improper consideration. CONTRACTOR shall make the Report either to COUNTY manager charged with the supervision of the employee or to COUNTY Fraud Hotline at (800) 544-6861 or www.lacountyfraud.org. Among other items, improper consideration may take the form of cash; discounts; service; or the provision of travel, entertainment, or tangible gifts.

N. COUNTY's Quality Assurance Plan

COUNTY or its agent will monitor CONTRACTOR's performance under this CONTRACT on not less than an annual basis. Such monitoring will include assessing CONTRACTOR's compliance with all this CONTRACT's terms and conditions and performance Standards. CONTRACTOR deficiencies which COUNTY determines are significant or continuing and that may place performance of this CONTRACT in jeopardy, if not corrected, will be reported to the Board. The Report will include improvement/corrective action measures taken by COUNTY and CONTRACTOR.

If improvement does not occur consistent with the corrective action measures, COUNTY may suspend or terminate this CONTRACT for default or impose other penalties as specified in this CONTRACT.

O. Local Small Business Enterprise Utilization

When requested by COUNTY, CONTRACTOR shall provide to COUNTY via methods specified by COUNTY, such as submission of electronic live (or dynamic) data on invoices for the prime and all Subcontractors using COUNTY-designated third-Party software system or to a COUNTY approved website, or other means of submitting expenditure information on Subcontractors, including but not limited to the following information: the name, business address and telephone number/email address of each Subcontractor.

In addition, CONTRACTOR shall be required to provide each of the specified Subcontractor Local Small Business Enterprise (SBE), Disabled Veteran Business Enterprise (DVBE), and Social Enterprise (SE) status (i.e., whether any of the listed Subcontractors are Local SBE's) and the proposed monetary amount of the work the Subcontractor will perform on each Notice to Proceed. At the time of submittal of each invoice, CONTRACTOR shall indicate, via methods specified by COUNTY, the actual dollar amounts paid to each listed Subcontractor who performed work on the project. The Subcontractor may be requested to confirm receipt of the actual payment to the Subcontractor by the prime.

The Parties agree that it will be impracticable or extremely difficult to fix the extent of actual damages resulting from the failure to CONTRACTOR to comply with this Section. The Parties will agree that under the current circumstances a reasonable estimate of such damages is specified in Exhibit F, Performance Requirements Summary, and that CONTRACTOR shall be liable to COUNTY for said amount.

If in the judgment of Director, or his/her designee, CONTRACTOR is deemed to be in non-compliance with the terms and obligations, Director or his/her designee, at his/her option, in addition to, or in lieu of, other remedies provided in Exhibit F, Performance Requirements Summary, may deduct and withhold liquidated damages from COUNTY's final payment to CONTRACTOR.

P. Compliance with COUNTY's Zero Tolerance Human Trafficking

CONTRACTOR acknowledges that COUNTY has established a Zero Tolerance Human Trafficking Policy prohibiting contractors from engaging in human trafficking.

If a CONTRACTOR or member of CONTRACTOR's staff is convicted of a human trafficking offense, COUNTY shall require that CONTRACTOR or member of CONTRACTOR's staff be removed immediately from performing services under the CONTRACT. COUNTY will not be under any obligation to disclose confidential information regarding the offenses other than those required by law.

Disqualification of any member of CONTRACTOR's staff pursuant to this paragraph shall not relieve CONTRACTOR of its obligation to complete all work in accordance with the terms and conditions of this CONTRACT.

Q. Method of Payment and Required Information

The County may, at its sole discretion, determine the most appropriate, efficient, secure, and timely form of payment for any amounts due for goods and/or services provided under an agreement or contract with the County. Proposers/Contractors further agree that the default form of payment shall be Electronic Funds Transfer (EFT) or direct deposit, unless an alternative method of payment is deemed appropriate by the Auditor-Controller (A-C).

Upon contract award and at the request of the A-C and/or the contracting department, the Contractor shall provide the A-C with electronic banking and related information for the Contractor and/or any other payee that the Contractor designates to receive payment pursuant to this agreement or contract. Such electronic banking and related information includes, but is not limited to: bank account number and routing number, legal business name, valid taxpayer identification number or TIN, a working e-mail address capable of receiving remittance advices and other payment related correspondence, and any other information that the A-C determines is reasonably necessary to process the payment and comply with all accounting, record keeping, and tax reporting requirements.

Any provision of law, grant, or funding agreement requiring a specific form or method of payment other than EFT or direct deposit shall supersede this requirement with respect to those payments. Upon contract award or at any time during the duration of the agreement or contract, a contractor may submit a written request for an exemption to this requirement. Such request must be based on specific legal, business or operational needs and explain why the payment method designated by the A-C is not feasible and an alternative is necessary. The A-C, in consultation with the contracting department(s), shall decide whether to approve exemption requests.

R. Compliance with Fair Chance Employment Practices

Contractor shall comply with fair chance employment hiring practices set forth in California Government Code Section 12952, Employment Discrimination: Conviction History. Contractor's violation of this paragraph of the Contract may constitute a material breach of the Contract. In the event of such material breach, County may, in its sole discretion, terminate the Contract.

S. Compliance with the County Policy of Equity

The contractor acknowledges that the County takes its commitment to preserving the dignity and professionalism of the workplace very seriously, as set forth in the County Policy of Equity (CPOE) (<https://ceop.lacounty.gov/>). The contractor further acknowledges that the County strives to provide a workplace free from discrimination, harassment, retaliation and inappropriate conduct based on a protected characteristic, and which may violate the CPOE. The contractor, its employees and subcontractors acknowledge and certify receipt and understanding of the CPOE. Failure of the contractor, its employees or its subcontractors to uphold the County's expectations of a workplace free from harassment and discrimination, including inappropriate conduct based on a protected characteristic, may subject the contractor to termination of contractual agreements as well as civil liability.

PART 4 - INDEMNIFICATION AND INSURANCE

A. Indemnification and Release of COUNTY

CONTRACTOR shall release, Indemnify, defend, and hold harmless COUNTY and County's Related Parties from and against all Liabilities arising from, connected with, or relating to all the following:

1. Operations

CONTRACTOR and Contractor's Related Parties' operations or any of their respective services on or after the date of this CONTRACT, including the Contract Services and Liabilities further detailed in the following Indemnifications contained in Part 4A2 through Part 4A5 of this Exhibit 5, but excluding any Liabilities arising from the sole active negligence of COUNTY.

2. Cal/OSHA

Without limiting the operations Indemnification in Part 4A1 of Exhibit 5, employer sanctions and any other Liabilities that may be assessed against CONTRACTOR or COUNTY or both about any alleged act or omission of CONTRACTOR or any of Contractor's Related Parties that is in violation of any Cal/OSHA regulation. This obligation includes all investigations and proceedings associated with purported violations of 8 CCR 336.10 pertaining to multiemployer work sites. CONTRACTOR shall not be obligated to so release, Indemnify, defend, and hold harmless COUNTY from and against any Liabilities arising from the active negligence of COUNTY.

3. Immigration

Without limiting the operations Indemnification in Part 4A1 of Exhibit 5, employer sanctions and any other Liabilities that may be assessed against CONTRACTOR, any of Contractor's Related Parties or COUNTY or any one or all of them about any alleged violation of Federal Applicable Law (including the Immigration Reform and Control Act of 1986 (PL. 99-603) pertaining to the eligibility for employment of individuals performing Contract Services. CONTRACTOR shall not be obligated to so Indemnify, release, defend, and hold harmless COUNTY from and against any Liabilities arising from active negligence of COUNTY.

1. Enforcement of CONTRACT or Applicable Law

Without limiting the operations Indemnification in Part 4A1 of Exhibit 5, any Liabilities that may be assessed against CONTRACTOR, any of Contractor's Related Parties or COUNTY or any one or all of them about any alleged failure of COUNTY to exercise COUNTY's rights under this

CONTRACT or to enforce provisions of this CONTRACT or of Applicable Law as permitted under Part 11A4 of Exhibit 5.

2. **Disposal**

The presence, Disposal, escape, migration, leakage, spillage, discharge, release, or emission of Unpermitted Waste or petroleum to, in, on, at, or under any Vehicle, place, site, or facility where CONTRACTOR or any of Contractor's Related Parties transports, delivers, stores, processes, Recycles, Composts or Disposes of Solid Waste to the extent that Liabilities are caused indirectly or directly by any of the following:

a. ***CONTRACTOR Negligence or Misconduct***

The wrongful, willful, or negligent act, error or omission, or the misconduct of CONTRACTOR or any of Contractor's Related Parties;

b. ***Non-Customer Materials***

The Collection, delivery, handling, Recycling, Processing, Composting or Disposal by CONTRACTOR or any of Contractor's Related Parties of any materials or waste, including Unpermitted Waste, that are generated by Persons other than Customers and Occupants or Collected from Premises other than Premises;

c. ***Failure to Comply with Unpermitted Waste Screening Protocol***

The failure of CONTRACTOR or any of Contractor's Related Parties to undertake Unpermitted Waste training procedures required by Applicable Law or the Unpermitted Waste Screening Protocol, whichever is more stringent; or

d. ***CONTRACTOR-Identified Unpermitted Waste***

The improper or negligent Collection, handling, delivery, Processing, Recycling, Composting, or Disposal by CONTRACTOR or any of Contractor's Related Parties of Unpermitted Waste that CONTRACTOR or any of Contractor's Related Parties inadvertently Collects from Customers and Occupants and that CONTRACTOR or any of Contractor's Related Parties identifies as Unpermitted Waste before its delivery, Processing, Recycling, Composting, or Disposal whether:

- (1) In one or more occurrence;
- (2) Threatened or transpired;

- (3) CONTRACTOR or any of Contractor's Related Parties is negligent or otherwise culpable; or
- (4) Those Liabilities are litigated, settled, or reduced to judgment.

For purposes of this item A5, "Liabilities" includes Liabilities arising from or attributable to any operations, repair, cleanup, or detoxification, or preparation and implementation of any removal, remedial, response, closure, post-closure, or other plan, regardless of whether undertaken due to government directive or action, such as remediation of surface or ground water contamination and replacement or restoration of natural resources.

The foregoing Indemnification under this item A5 is intended to operate as a CONTRACT under 42 U.S.C. Section 9607(e) and California Health and Safety Code Section 25364, to insure, protect, hold harmless, and Indemnify COUNTY from liability in accordance with this Section.

The mere presence of household hazardous waste in the Solid Waste that is Collected by CONTRACTOR or any of Contractor's Related Parties under this CONTRACT will not constitute negligence and in and of itself create any liability on the part of CONTRACTOR or any of Contractor's Related Parties absent any of the circumstances described in items a through d in this item A5.

With respect to COUNTY's defense under this item A5, COUNTY reserves the right to retain co-counsel at its own cost and expense and CONTRACTOR shall direct CONTRACTOR's counsel to assist and cooperate with COUNTY'S co-counsel.

CONTRACTOR hereby releases and shall not seek contribution or compensation of any nature from COUNTY for Liabilities relating to Unpermitted Waste, including relating to RCRA, CERCLA, or the California Health and Safety Code. CONTRACTOR shall not make any claims against or assert an interest in any account, fund, or reserve that COUNTY may establish or otherwise or maintains to cover Liabilities relating to Unpermitted Waste, which established fund or reserve COUNTY is under no obligation to establish or maintain.

B. Insurance

Without limiting its Indemnities, and in the performance of this CONTRACT and until all its Performance Obligations pursuant to this CONTRACT have been met, CONTRACTOR shall provide and maintain the following programs of insurance at its own expense. Performance Obligations under this Section are in addition to and separate from any other Performance Obligation in this CONTRACT. COUNTY reserves the right to review and adjust the insurance requirements in this Section if COUNTY determines that there have been changes in risk exposures. COUNTY makes no warranty that the insurance coverage terms,

types, and limits in this Part 4B is sufficient to protect CONTRACTOR for Liabilities that may arise from or in relation to this CONTRACT.

1. **Primary, Excess, Non-Contributory**

All CONTRACTOR's insurance carried under this Part 4B shall be primary with respect to any other insurance or self-insurance programs available to COUNTY.

2. **Cancellation Notices**

All insurance shall contain the express condition that COUNTY is to be given written Notice by mail at least 30 days in advance of cancellation, or at least ten days in advance of cancellation for nonpayment of premium, for all policies evidenced on the certificate of insurance.

3. **Noncompliance**

Neither COUNTY'S failure to obtain, nor COUNTY'S receipt of, or failure to object to a noncomplying insurance certificate or endorsement or any other insurance documentation or information provided by CONTRACTOR, its insurance broker(s) and/or insurer(s), shall be construed as a waiver of any Performance Obligation under this Part 4B. If CONTRACTOR does not provide and maintain those programs of insurance, COUNTY may purchase required insurance coverage without further Notice to CONTRACTOR, and COUNTY may charge CONTRACTOR any premium costs advanced by COUNTY for that insurance and draw on the Performance Assurance provided by CONTRACTOR.

4. **Evidence of Insurance: COIs and copies of policies**

At least 30 days prior to the Execution Date and thereafter 30 days prior to each policy renewal and within two business days of any Director request, CONTRACTOR shall deliver a certificate or certificates of insurance or other evidence of coverage acceptable to Director at the address provided for Notices. Certificates or other evidence must:

a. *Specifically identify this CONTRACT by name or number*

name the insured Party that matches the name of CONTRACTOR executing this CONTRACT; provide the full name of each insurer providing coverage and the insurer's NAIC (National Association of Insurance Commissioners) identification number, and financial rating.

b. *Types and limits*

Clearly evidence all coverage, types, and limits required in this CONTRACT. Identify standard policy forms or their equivalent. Coverage may consist of a combination of primary and excess policies. Excess policies must provide coverage as broad as "follow form" over the underlying primary policies;

c. Cancellation Notice

Contain the express condition that Director is to be given written Notice by mail at least 30 days in advance of cancellation (ten days for nonpayment of premium) for all policies evidenced on the certificate of insurance;

d. List additional endorsements

(1) Additional insured endorsements. Include copies of the additional insured endorsements to General Liability Policy which must add COUNTY and its Special Districts, elected officials, officers, agents, and employees as additional insureds with respect to liability arising out of ongoing and completed Contract Services, and applicable with respect to liability and defense of suits arising out of CONTRACTOR's acts or omissions, whether that liability is attributable to CONTRACTOR or COUNTY. The full policy limits and scope of protection must apply to each of those additional insureds even if those limits or scope exceed the minimum required insurance specifications in this CONTRACT. CONTRACTOR may use an automatic additional insured endorsement if the endorsements meet the requirements of this Part 4B.

(2) Waiver of Subrogation Endorsements. Include copies of subrogation endorsements necessary to effect CONTRACTOR's waiver of its and its insurer(s)' rights of recovery against COUNTY under all insurance under this Section 14B, to the fullest extent permitted by law.

e. Deductibles and SIRs

Identify any deductibles or self-insured retention ("SIR") exceeding \$50,000 for Director's approval. CONTRACTOR's policies shall not obligate COUNTY to pay any portion of any CONTRACTOR deductible or SIR.

COUNTY retains the right to require CONTRACTOR to reduce any deductibles or self-insured retention as they apply to COUNTY or to require CONTRACTOR to provide a bond, letter of credit, or certificate of deposit guaranteeing payment of all retained losses and

related costs, including expenses, or both, related to investigations, claims administrations, and defense. The bond must be executed by a corporate surety licensed to transact business in the State of California; the letter of credit must be issued by a bank or other financial institution acceptable to Director.

If CONTRACTOR has not reached its SIR maximum, CONTRACTOR shall defend COUNTY in the same manner that insurers would have defended COUNTY under required insurance policies.

f. Signature verification

Include documentation acceptable to Director verifying that the individual signing or countersigning the certificates, and at Director's request, the policies, endorsements, or other evidence of coverage, is authorized to do so and identifies his or her company affiliation and title.

g. Certified Copies of any Policy

COUNTY's request, CONTRACTOR shall Promptly provide COUNTY with complete, certified copies of any policy of insurance that CONTRACTOR must secure and maintain under this CONTRACT.

h. Claims Made/Retroactive Date

The policy retroactive date, which can be identified on any insurance written on claims made basis, which must precede the Execution Date. CONTRACTOR shall maintain any claims made coverage for a period of not less than 3 years following expiration, termination, or cancellation of this CONTRACT.

i. Insured-vs.-insured

Clearly evidence that all liability policies provide cross-liability coverage as would be afforded by the standard ISO (Insurance Services Office, Inc.) separation of insureds provision with no insured-versus-insured exclusions or limitations.

5. Insurer Financial Rating

CONTRACTOR shall secure insurance provided by an insurance company acceptable to COUNTY with a rating by A.M. Best Company of not less than A: VII, unless otherwise approved by COUNTY.

6. Notification of Incidents, Claims, or Suits

CONTRACTOR shall Promptly report the following in writing to Director:

- a. Any accident or incident relating to the Contract Services involving injury or property damage that may result in the filing of an insurance claim, its legal claim, or lawsuit against CONTRACTOR, any Subcontractor, and/or COUNTY;
- b. Any third-Party claim or lawsuit filed against CONTRACTOR arising from or related to Contract Services;
- c. Any injury to a CONTRACTOR employee that occurs on COUNTY property, or,
- d. Any loss, disappearance, destruction, misuse, or theft of COUNTY property, money, or securities entrusted to CONTRACTOR.

CONTRACTOR shall submit its Report on a COUNTY "Nonemployee Injury Report" form available on COUNTY's website at <http://cao.co.la.ca.us/RMB/pdf/NonEmployeeInjuryReport.pdf>.

7. Insurance Coverage Requirements.

CONTRACTOR shall secure and maintain insurance coverage meeting the following requirements:

- a. **General Liability Insurance** (written on ISO policy form CG 00 01 or its equivalent) with limits of not less than the following:

General Annual Aggregate:	\$4 million
Products/Completed Operations Aggregate:	\$4 million
Personal and Advertising Injury:	\$1 million
Each Occurrence:	\$2 million

The general liability policy must provide contractual liability coverage for CONTRACTOR's Indemnification of COUNTY.

- b. **Pollution Liability Coverage** for pollution conditions resulting from transported cargo, with annual limits of not less than \$2 million per occurrence and \$4 million aggregate, covering loss (including cleanup costs) that CONTRACTOR becomes legally obligated to pay as a result of claims for bodily injury, property damage, and cleanup costs (including expenses required by environmental laws or incurred by Federal, State, or local governments or third Parties) resulting from pollution conditions caused by transported cargo (including waste). For the purpose of this Part 4B7b, "pollution conditions" includes the dispersal, discharge, release, or escape of any solid, liquid, gaseous, or thermal irritant or contaminant (such as smoke, vapors, soot,

fumes, acids, alkalis, toxic chemicals, medical waste, and waste materials) into or upon land, any structure on land, the atmosphere, or any watercourse or body of water (including groundwater), provided the conditions are not naturally present in the environment in the amounts or concentrations discovered. The pollution liability coverage must provide contractual liability coverage, by endorsement, if necessary, for CONTRACTOR's Indemnification of COUNTY. CONTRACTOR's general liability policy may be endorsed to provide the required pollution liability coverage.

c. **Automobile Liability Coverage** (written on ISO policy forms CA 00 12 or CA 00 20 or their equivalent) with a limit of liability not less than \$2 million for each accident and endorsed to include pollution liability (written on form CA 99 48 or its equivalent). The insurance must cover all Vehicles used by CONTRACTOR pursuant to its operations and services and the terms of this CONTRACT. CONTRACTORS subject to Federal regulations also shall maintain any other coverage necessary to satisfy State or Federal financial responsibility requirements.

d. **Workers' Compensation and Employers' Liability** insurance providing workers' compensation benefits required by the California Labor Code or by any other State labor law, and for which CONTRACTOR is responsible. In all cases, this insurance must also include Employers' Liability coverage with limits of not less than the following:

(1)	Each accident:	\$1 million
(2)	Disease - policy limit:	\$1 million
(3)	Disease - each employee:	\$1 million

8. Insurance Coverage Requirements for Subcontractors

CONTRACTOR shall ensure that all Subcontractors performing Contract Services under this CONTRACT secure and maintain the insurance coverage required in Part 4B1 through B7 by providing evidence that either:

- o CONTRACTOR is maintaining the required insurance covering the activities of Subcontractors, or
- o Subcontractors are maintaining the required insurance coverage.

CONTRACTOR shall provide COUNTY with any Subcontractor request to modify that insurance coverage and get COUNTY approval prior to modification.

C. Compensation for COUNTY Costs

If CONTRACTOR fails to comply with any Performance Obligations, including Indemnification, insurance, and performance assurance and that failure results in any costs to COUNTY, CONTRACTOR shall pay full compensation for all County's Reimbursement Costs.

D. Alternative Risk Financing Programs

COUNTY reserves the right to review and then approve CONTRACTOR's use of self-insurance, risk retention groups, risk purchasing groups, pooling arrangements, and captive insurance to satisfy Performance Obligations under this Part 4B. COUNTY and Persons named as additional insureds under Part 4B4d shall be designated as an Additional Covered Party under any approved program.

PART 5 - Part no longer used

PART 6 - DEBARMENT BREACHES AND DEFAULTS; SUSPENSION; TERMINATION

A. Notice of Breach; CONTRACTOR Cure

If Director determines that CONTRACTOR is in Breach, Director may give Notice to CONTRACTOR identifying and describing the Breach.

CONTRACTOR shall remedy the Breach within 30 days from the receipt of Notice unless Director determines that the public health and safety require a shorter period. CONTRACTOR shall remedy a Breach or with respect to the Child Support Compliance Program described in Part 11B of Exhibit 5, 90 days after Notice by the COUNTY's Child Support Services Department. Director will hold a conference with CONTRACTOR within 30 days of CONTRACTOR request. CONTRACTOR may request additional time to correct the Breach, but Director may accept or reject that request at its sole discretion.

B. Contractor Default. The following constitute Contractor Defaults

1. Fraud, Misrepresentation, or Breach of Warranties

CONTRACTOR committed any fraud or deceit or made any intentional misrepresentations in the procurement of this CONTRACT; commits, or attempts to commit, any fraud or deceit upon COUNTY after the Award Date of this CONTRACT; makes any material misrepresentations or breaches any warranties in this CONTRACT (including Attachment 5-9H); or includes any materially false or misleading statement, representation, or warranty in any Record or Report.

2. Insolvency or Bankruptcy

CONTRACTOR becomes insolvent or files a voluntary petition to declare bankruptcy; a receiver or trust is appointed for CONTRACTOR; or CONTRACTOR executes an assignment for the benefit of creditors. CONTRACTOR is deemed to be "insolvent" if it has ceased to pay its debts in the ordinary course of business or cannot pay its debts as they become due, whether CONTRACTOR has committed an act of bankruptcy and whether CONTRACTOR is insolvent within the meaning of the Federal bankruptcy law or not.

3. Failure to Provide Insurance, Bonds

CONTRACTOR does not provide or maintain in full force and effect all insurance and other assurances of its Performance Obligations, including as required under Part 4 of Exhibit 5 and Section 15, or provide evidence of insurance coverage acceptable to Director.

4. Material or Repeated Violation of Applicable Law

a. Any material Violation of Applicable Law

That is not cured to the satisfaction of Director or applicable Regulatory Agency within 30 days of the Notice, assessment, or determination of that Violation of Applicable Law; or

b. Any repeated Violation of Applicable Law

If CONTRACTOR is entitled to and does contest a Notice, assessment, or determination of Violation of Applicable Law by proceedings conducted in good faith, no Contractor Default will be deemed to have occurred until a final decision adverse to CONTRACTOR is entered.

5. Failure to Collect for Seven Days

Unless due to Uncontrollable Circumstances or otherwise approved by Director, CONTRACTOR fails to Collect from all Occupants with respect to Task 1 or to provide Task 2 Services for seven consecutive calendar days.

6. Failure to Collect for More Than Seven Days

With respect to Task 1 or Task 2 Services, if due to Uncontrollable Circumstances, CONTRACTOR fails to Collect from all Occupants or provide Task 2 Services for a period of more than seven consecutive calendar days.

7. Payments to COUNTY

CONTRACTOR does not timely and fully make any required payment to COUNTY required under this CONTRACT (including payments such as damages or County's Reimbursement Costs):

a. More than twice in any Calendar Year;

b. Within 60 days of Notice by Director that payment is due; or

8. Specified Contractor Defaults

CONTRACTOR Breaches any of the following Sections:

a. Part 11B of Exhibit 5 Child Support Compliance Program (if not cured within 90 days of Notice given as described in Part 6 of Exhibit 5);

- b. *Part 12C1 of Exhibit 5 Compliance with ILO Convention Concerning Minimum Age for Employment;*
- c. *Part 12D of Exhibit 5 Nondiscrimination;*
- d. *Part 12F of Exhibit 5 County Lobbyist Ordinance; or*
- e. *Part 6F of Exhibit 5 Termination for Breach of Warranty to Maintain Compliance with COUNTY's Defaulted Property Tax Reduction Program.*

9. Uncured or Repeated Breach

CONTRACTOR does not timely cure any other Breach in accordance with item A or CONTRACTOR Breaches any of its Performance Obligations repeatedly or habitually, as determined by Director at their sole discretion, if a specific instance of failure or refusal has been previously cured. However, this Contractor Default will be excused for a period of seven days beginning on the first occurrence of that Contractor Default in the event of Uncontrollable Circumstances, if the event materially affects CONTRACTOR's ability to provide Contract Services. Nevertheless, if Uncontrollable Circumstances interrupt Collection, Customers and Occupants may take actions and COUNTY may exercise any of its rights under Section 11. This Contractor Default will not be excused if it continues for a period of more than seven days beginning on the first occurrence of this Contractor Default.

10. Improper Consideration

COUNTY finds that consideration, in any form, was offered or given by CONTRACTOR either directly or through an intermediary to any COUNTY officer, employee, or agent with the intent of securing this CONTRACT or securing favorable treatment with respect to the award, amendment, or extension of this CONTRACT or the making of any determinations with respect to CONTRACTOR's performance under this CONTRACT where that consideration may take any form including cash; discounts; service; or the provision of travel, entertainment, or tangible gifts.

11. Default Under Guaranty

A default exists under the guaranty, if any, provided in the most recent annual public financial Reports and other periodic public financial Reports of CONTRACTOR and, at Director's request, each of its Affiliates and other entities, if any, performing Contract Services or providing Goods or Services; provided however, that if CONTRACTOR did not submit its own financial Reports before the Execution Date of this CONTRACT, it must provide a guaranty in the form provided by Director, by a guarantor

satisfactory to Director, which guarantor must provide its own audited financial Reports;

C. Notice of Contractor Default

1. Effective Immediately

COUNTY may terminate this CONTRACT effective immediately after Notice by Director to CONTRACTOR of any of the following Contractor Defaults:

- a. *Any Contractor Default, if COUNTY determines that protection of public health and safety requires immediate suspension or termination;*
- b. *A Contractor Default in Part 6B3 of Exhibit 5 (failure to provide insurance, bonds);*
- c. *A Contractor Default described in Part 6B4 of Exhibit 5 (material or repeated Violation of Applicable Law, including County Lobbyist Ordinance);*
- d. *A Contractor Default described in Part 6B10 of Exhibit 5 (improper consideration).*

1. Effective 30 days

COUNTY may terminate this CONTRACT effective 30 days after Notice by Director to CONTRACTOR of any Contractor Default other than Contractor Defaults listed in this Part 6C1 of Exhibit 5 or termination events listed in Part 6D of Exhibit 5.

2. Effective 15 days

COUNTY may terminate this CONTRACT effective 15 days after Notice by Director to CONTRACTOR of COUNTY's right to terminate this CONTRACT in the event of Criminal Activity in accordance with Part 9K of Exhibit 5 and Part 6D2c of Exhibit 5.

3. Effective Ten days

COUNTY may terminate this CONTRACT effective ten days after Notice given by Director for failure to comply with County Defaulted Property Tax Reduction Program in accordance Part 6F of Exhibit 5.

D. Suspension or Termination of CONTRACT

1. Suspension

Together with any other rights COUNTY may have under this CONTRACT, Director may suspend this CONTRACT, in whole or in part, for a period of 45 days effective immediately upon Notice to CONTRACTOR in any of the following events:

a. *A Contractor Default*

b. *COUNTY Right*

COUNTY exercise of its right to suspend this CONTRACT under Part 9K of Exhibit 5 in the event of Criminal Activity of CONTRACTOR; or

c. *Other*

Any other Contractor Default in Exhibits 3A1 or 3A2.

During that 45-day period CONTRACTOR shall have the opportunity to demonstrate to Director that CONTRACTOR can once again fully perform Contract Services in accordance with this CONTRACT. If CONTRACTOR so demonstrates, COUNTY's right to suspend this CONTRACT will cease and CONTRACTOR may resume providing services. If CONTRACTOR does not so demonstrate, COUNTY may continue the suspension and terminate this CONTRACT and exercise any other rights and remedies under this CONTRACT.

2. Termination

a. *Contractor Default*

COUNTY may terminate this CONTRACT, in whole or in part, upon the occurrence of a Contractor Default and Notice to CONTRACTOR at the times provided in Part 6D3 of Exhibit 5.

b. *Failure to Agree on Service Fee Adjustments*

Notwithstanding the foregoing, COUNTY may terminate this CONTRACT on 6 months' Notice if in the judgment of Director, COUNTY and CONTRACTOR are unable to reach satisfactory CONTRACT to adjust Service Fees in accordance with items B, C, D, and E of Exhibit 7 for a Change in Law or changes in Service Specifications or Service Standards after good faith negotiations during a period of at least 30 days.

c. Criminal Activity

COUNTY may terminate this CONTRACT upon Notice required in Part 6C of Exhibit 5 if COUNTY exercises its right to terminate this CONTRACT under Part 9K of Exhibit 5 in the event of Criminal Activity of CONTRACTOR.

d. Annexation of Service Area

It is understood that in the event of the dissolution of all or a portion of the Service Area, this CONTRACT and all obligations of either of the Parties thereto shall be at an end, whether such dissolution results from proceedings under the provisions of the act pursuant to which the Service Area was created, by operation of law, or resulting from municipal annexation or incorporation, except for record retention requirements.

Upon request of Director, CONTRACTOR shall use Reasonable Business Efforts to cooperate with a local agency with respect to providing Customers Services and County Services or MSW Management Services, in the following events:

- (1) the Service Area is annexed by that local agency in accordance with applicable laws, and
- (2) the Parties agree to amend this CONTRACT to delete the annexed area from the definition of "Service Area".

COUNTY will provide information regarding any known annexations or incorporations at the bidder's conference; however, CONTRACTOR is responsible for investigating the Service Area and determining which areas are prone to annexation or incorporation. For example, the City of Santa Clarita has annexed portions of the unincorporated communities of the County of Los Angeles and it is reasonable to expect additional annexations during the Term of this CONTRACT.

3. Suspension/Termination for Nonappropriation of Funds

Notwithstanding any other provision of this CONTRACT, COUNTY shall not be obligated for CONTRACTOR's performance hereunder, with respect to County Services under this Exhibit during any of COUNTY's future Fiscal Years unless and until the Board appropriates funds for this CONTRACT in COUNTY's budget for each such future Fiscal Year. If funds are not appropriated for this CONTRACT, then this CONTRACT may be suspended or terminated as of June 30 of the last Fiscal Year for which funds were

appropriated. Director will notify CONTRACTOR in writing of any such nonallocation of funds as soon as possible.

4. Suspension/Termination for Convenience (County Services Only)

a. *COUNTY's Best Interest*

With respect to County Services only, COUNTY policy requires that this CONTRACT may be suspended or terminated, in whole or in part, from time to time, when COUNTY deems such action, at its sole discretion, to be in its best interest. Suspension or termination of work hereunder shall be affected by Notice of suspension or termination to CONTRACTOR specifying the extent to which performance of work is suspended or terminated and the date upon which such suspension or termination becomes effective. The date upon which such suspension or termination becomes effective shall be no less than ten days after the Notice is sent.

b. *Stop Suspended/Terminated Work; Complete Non-Suspended/Terminated*

After receipt of a Notice of suspension or termination and except as otherwise directed by Director, CONTRACTOR shall:

- (1) Stop work under this CONTRACT on the date and to the extent specified in such Notice; and
- (2) Complete performance of such part of the work as shall not have been suspended or terminated by such Notice.

c. *Records Retention*

All material including books, Records, documents, or other evidence bearing on the costs and expenses of CONTRACTOR under this CONTRACT shall be maintained by CONTRACTOR in accordance with Section 9A and Part 3G of Exhibit 5.

d. *Completion of Work*

If this CONTRACT is suspended or terminated, CONTRACTOR shall complete within Director's suspension or termination date contained within the Notice of suspension or termination, those items of work which are in various stages of completion, which Director has advised CONTRACTOR are necessary to bring the work to a timely, logical, and orderly end. Reports, samples, and other materials prepared by CONTRACTOR under this CONTRACT shall be delivered to Director upon request and shall become the property of COUNTY.

e. ***Suspension or Termination in Part***

COUNTY may suspend or terminate part of this CONTRACT. An example of suspension or termination in part is suspending Task 1 Service but not Task 2 Service.

E. **CONTRACTOR Responsibility and Debarment**

1. **Child Support Compliance Program**

COUNTY may debar CONTRACTOR from doing business with COUNTY if COUNTY determines after giving Notice and conducting a hearing in accordance with Chapter 2.202 of County Code, which shall apply to this CONTRACT, that CONTRACTOR (or any of its Subcontractors) is not responsible within the meaning of Chapter 2.202 and in accordance with COUNTY's policy to do business with responsible contractors; CONTRACTOR's failure to comply with the Child Support Compliance Program, as provided in Part 11B of Exhibit 5, may be cause for debarment in accordance with Section 2.200.020 of County Code.

2. **County Defaulted Property Tax Reduction Program**

COUNTY may debar CONTRACTOR from doing business with COUNTY as provided in item F2 of this Exhibit.

F. **Termination For Breach Of Warranty To Maintain Compliance With County Defaulted Property Tax Reduction Program**

1. **Contractor Default**

Failure of CONTRACTOR to maintain compliance with the requirements set forth in Part 11C of Exhibit 5 shall constitute a Contractor Default under Part 6B of Exhibit 5.

2. **Termination/Debarment**

Without limiting the rights and remedies available to COUNTY under any other provision of this CONTRACT, failure of CONTRACTOR to cure that Contractor Default within ten days of Notice shall be grounds upon which COUNTY may terminate this CONTRACT under Part 6D2a of Exhibit 5 and/or pursue debarment of CONTRACTOR pursuant to County Code Chapter 2.206 and Part 6E2 of Exhibit 5.

PART 7 - Part no longer used

PART 8 - TRANSFER OF CONTRACT

A. COUNTY Consent

CONTRACTOR may not transfer this CONTRACT or any rights or duties under it, in whole or in part, and whether voluntarily or involuntarily, without COUNTY's prior written consent given at COUNTY's sole discretion. Any transfer or attempted transfer of this CONTRACT, the franchise granted under it or any rights and duties under it, made without COUNTY'S consent, at COUNTY's option, will be invalid. COUNTY's consent must be a written amendment to this CONTRACT that is formally approved by the Board of Supervisors and executed by (1) CONTRACTOR and (2) the Board, or if delegated by the Board, Director. Any transfer, with or without consideration for any reason whatsoever without COUNTY's (or Director's, if applicable) express prior written approval, shall be a Breach of this CONTRACT, which may result in the termination of this CONTRACT. In the event of such termination, COUNTY shall be entitled to pursue the same remedies against CONTRACTOR as it could pursue in the event of default by CONTRACTOR. COUNTY may condition consent on payment of amounts specified in Exhibit 3A1, Exhibit 3A2, and Exhibit 3A3 in consideration for the value of good will and intangibles that accrued to COUNTY and Customers and Occupants in the award of this CONTRACT to CONTRACTOR.

"Transfer" means an action (or inaction) that has any of the following direct (or indirect) effects:

1. Control or Ownership of CONTRACTOR

Changing any or all of the following:

- The effective control of CONTRACTOR, or
- Ownership interest of CONTRACTOR (including buyout, merger, acquisition, consolidation, reorganization, recapitalization, stock (re)issuance, voting trust, pooling agreement, escrow arrangement, dissolution, or liquidation (except to Immediate Family or a trust created primarily to benefit members of the Immediate Family) unless CONTRACTOR proves to satisfaction of COUNTY less than 25 percent of ownership interest has changed;

2. Control or Ownership of Contract Service Assets

Changing either or both of the following:

- The effective control

- The ownership (actual or constructive) of Contract Service Assets (except for sales or transfers to the Immediate Family or a trust created primarily to benefit the Immediate Family) unless CONTRACTOR proves to satisfaction COUNTY that less than 20 percent of the value of Service Assets has changed ownership.

3. Someone Other Than CONTRACTOR Performing Contract Services

Resulting in someone other than CONTRACTOR performing contract services or assuming the obligation to provide Contract Services (including substitution of someone else by a surety company providing a performance bond, transfer, conveyance, sublease, or licensing).

For purposes of this definition, an action (or inaction) includes assignment by operation of law, such as insolvency or bankruptcy, making assignment for the benefit of creditors, writ of attachment of an execution levied against this Agreement, appointment of a receiver taking possession of any of CONTRACTOR's tangible or intangible property, or transfer occurring in a probate or other estate proceeding.

"Immediate Family" means parents, grandparents, siblings, children, and grandchildren of individuals having a shareholder or other equity interest in CONTRACTOR as of the Execution Date.

"ownership" means the state or fact of being the direct (or indirect), actual (or constructive) owner of property, including a parent holding corporation owning stock of a subsidiary corporation that in turn owns stock in its own subsidiary corporation(s).

B. **CONTRACTOR Demonstration**

Without obligating Director to give consent, CONTRACTOR shall demonstrate to Director's satisfaction that the proposed transferee has the operational and financial ability to satisfy CONTRACTOR's Performance Obligations.

C. **Payment of COUNTY's Transfer Costs**

1. Transfer Deposit

CONTRACTOR must make any request for Director's consent to a transfer in the manner prescribed by Director. Director may condition consent to any transfer, other than a transfer to an Affiliate, on CONTRACTOR's payment to COUNTY of \$5.00 per Customer. CONTRACTOR shall pay COUNTY a transfer Deposit before Director's consideration of CONTRACTOR's request. COUNTY will return to CONTRACTOR any amounts paid more than the transfer Costs incurred.

2. Additional Transfer Costs

While COUNTY's Processing CONTRACTOR's request for transfer, CONTRACTOR shall further pay COUNTY its additional transfer Costs more than the transfer Deposit within 30 days of Director's request therefore, if Director approves the transfer. At CONTRACTOR's request, COUNTY will provide CONTRACTOR access to all Records evidencing the transfer Costs incurred.

D. County's Reimbursement Costs of Enforcement

In addition, CONTRACTOR shall pay County's Reimbursement Costs for fees and investigation costs as COUNTY may deem necessary to enjoin the transfer or to otherwise enforce this provision within 30 days of COUNTY's request therefore.

Any payment by COUNTY to any approved delegate or transferee on any claim under this CONTRACT shall be deductible, at COUNTY's sole discretion, against the claims which CONTRACTOR may have against COUNTY.

PART 9 - GENERAL PROVISIONS

A. Exercise of Options

Parties will exercise any approval, disapproval, consent, judgment, option, discretion, election, opinion, or choice under this CONTRACT, make a requirement under this CONTRACT or interpret this CONTRACT "Discretionary Action" reasonably. Any mediator, arbitrator, or court must find the Party's exercise to be reasonable. Recognizing the essential public health and safety protections this CONTRACT serves, where this CONTRACT specifically provides that the exercise of any Discretionary Action is in either Party's independent, sole, exclusive, or absolute discretion, control, or judgment, the other Party will not question or challenge the first Party's exercise thereof. Parties will nevertheless exercise their rights and remedies in good faith in accordance with Applicable Law.

B. Independent Status

CONTRACTOR is an independent entity and not an officer, agent, servant, or employee of COUNTY. This CONTRACT is between COUNTY and CONTRACTOR and is not intended, and will not be construed, to create the relationship of agent, servant, employee, partnership, joint venture, or association between COUNTY and CONTRACTOR, including for purposes of workers' compensation. CONTRACTOR is solely responsible for the acts and omissions of its officers, agents, employees, and any Subcontractors. Nothing in this CONTRACT will be construed as creating an arrangement for handling Unpermitted Waste. CONTRACTOR bears the sole responsibility and liability for furnishing workers' compensation and all other benefits required by law to any individual for injuries arising from or connected with Contract Services performed on behalf of CONTRACTOR under this CONTRACT.

C. Damage to Property and Personal Injury

CONTRACTOR shall not cause damage to property or personal injury. At its sole expense, CONTRACTOR shall repair or replace to the satisfaction of the owner of damaged property, any physical damage to public or private property and shall reimburse to the satisfaction of an injured individual, the cost of any personal injury caused by the negligent or willful acts or omissions of CONTRACTOR. COUNTY may refer all complaints of damage or injury to CONTRACTOR as a matter within CONTRACTOR's sole responsibility. Notwithstanding any Rights COUNTY has for breach of CONTRACT, disputes between CONTRACTOR and Persons as to damage to private pavement or other property or to injury are civil matters between CONTRACTOR and that Person, and the Person may institute suits with respect thereto as allowed by law.

D. Venue

In the event of litigation between the Parties, venue in State of California trial courts will lie exclusively in COUNTY. In the event of litigation in a United States District Court, exclusive venue will lie in the Central District of California.

E. Changes and Amendments

1. Changes following Notice

The following changes in this CONTRACT after the Execution Date will be effective after Notice from Director to CONTRACTOR (or with respect to certain changes referenced in item b, from CONTRACTOR to Director, in accordance with Section 3D2a) as consented to by CONTRACTOR:

- a. Changes in the scope of Contract Services and Service Specifications and minimum Service Standards that do not result in a Customer Service Fee adjustment in accordance with Section 3C or change in County Service Fee*
- b. Changes to Exhibit 3D Contractor Documentation*
- c. Changes to Attachment 5-9G Authorized Representative of Director*
- d. Immaterial changes to immaterial Performance Obligations*

2. Written Amendments

The following changes in this CONTRACT after the Execution Date will be effective only upon execution of a written amendment to this CONTRACT, including warranties by the Parties in accordance with Section 14B:

- a. Changes in the scope of Contract Services and Service Standards that result in a Customer Service Fee adjustment in accordance with Section 3C or change in County Service Fee; and*
- b. Material changes to material Performance Obligations, such as the period of performance, payments, or any material Term or condition included in this CONTRACT.*

F. Notices

All Notices required or permitted to be given under this CONTRACT must be in writing with proof of delivery and acknowledgment by recipient. All Notices to COUNTY must be addressed to Director as provided in Attachment 5-9G, on CONTRACTOR letterhead, and signed by authorized representative. All Notices

to CONTRACTOR must be addressed to the authorized representative of CONTRACTOR named in Contractor Documentation in Exhibit 3D (who will be CONTRACTOR's primary contact under this CONTRACT).

COUNTY Notice to CONTRACTOR is deemed effective on the date delivered with evidence of receipt or three days after the date of mailing, as evidenced in proof of mailing and post-marked date on envelope.

Notices of suspension or termination of this CONTRACT may be personally delivered to any individual whose actual knowledge of suspension or termination would be sufficient Notice to CONTRACTOR, including:

1. An individual, if CONTRACTOR is a sole proprietor;
2. Copartner, if CONTRACTOR is a partnership; or
3. The president, vice president, secretary, or general manager, if CONTRACTOR is a corporation.

G. Authorized Representative of Director

COUNTY authorizes Director to make requests or requirements of CONTRACTOR or give approvals under this CONTRACT, excluding consents to transfer or written amendments of this CONTRACT. The authorized representative of Director named in Attachment 5-9G is CONTRACTOR's primary contact under this CONTRACT and can be contacted as provided in Attachment 5-9G. CONTRACTOR shall give that authorized representative a copy of all Notices in accordance with Part 9F of Exhibit 5. From time to time, Director may change Attachment 5-9G by Notice to CONTRACTOR.

H. Authority and Representations; COUNTY Disclaimer

1. COUNTY

COUNTY represents and disclaims as follows:

a. *Status*

COUNTY is a political subdivision of the State of California.

b. *Authority and Authorization*

COUNTY has full legal right, power, and authority to execute and deliver this CONTRACT and perform its obligations under this CONTRACT. This CONTRACT has been duly executed and delivered by COUNTY and constitutes a legal, valid, and binding

obligation of COUNTY enforceable against COUNTY in accordance with its terms.

c. No Warranty Regarding Waste Characterization

COUNTY makes no representations or warranties with respect to the waste characterization within COUNTY, any waste Disposal characterization study, or projections by material type with respect to waste in COUNTY. COUNTY expressly disclaims any representations and warranties, either express or implied, as to the merchantability or fitness for any purpose of Solid Waste or any portion thereof.

2. CONTRACTOR

CONTRACTOR represents and warrants as provided in Attachment 5-9H.

I. Limitation on Terms and Conditions

With respect to Task 1 only, CONTRACTOR shall limit the terms of terms and conditions to no longer than the remaining period of the Term. CONTRACTOR may not include in the terms of terms and conditions any automatic renewals or extensions, colloquially referred to as "evergreen" clauses, which obligate a Customer to take affirmative, prescribed action (such as written Notice within a specified time before the stated expiration of the terms and conditions) to terminate the terms and conditions.

J. 21-Day Notice by Customer

CONTRACTOR shall give each Customer the option to terminate its terms and conditions for services that are not Contract Services not included in a parcel's allotment of service paid through the property tax, without cause on 21-days' Notice. CONTRACTOR shall refund any advanced payment for service after termination.

K. Criminal Activity

1. Notice

CONTRACTOR shall immediately give Notice to Director on the occurrence of any convictions of a Criminal Activity or any pleas of "guilty," "nolo contendere," or "no contest" to a Criminal Activity with respect to CONTRACTOR or any of its Contractor Managers (except for Contractor Managers in a Position of Influence). CONTRACTOR shall use Reasonable Business Efforts to immediately give Notice to Director on the occurrence of any convictions or any pleas with respect to CONTRACTOR or any of its

Contractor Managers in a Position of Influence, and any of its CONTRACTOR employees who come in direct contact with the residents.

2. CONTRACTOR Cure

Upon the occurrence of any conviction or any plea described in Part 9K1 of Exhibit 5, CONTRACTOR immediately shall do or cause to be done both of the following:

a. *Terminate*

Terminate from employment or remove from office any offending Contractor Manager who is an individual, or with respect to CONTRACTOR or an Affiliate, the individual or individuals responsible for the Criminal Activity; and

b. *Eliminate*

Eliminate the participation in management of CONTRACTOR by that Contractor Manager who is an individual or, with respect to CONTRACTOR or an Affiliate, the individual or individuals responsible for the Criminal Activity from any Position of Influence.

3. COUNTY Remedies

COUNTY may suspend or terminate this CONTRACT or may impose other sanctions (which may include financial sanctions or any other condition deemed appropriate short of suspension or termination), as it deems proper, in either or both the following events:

a. *CONTRACTOR or any Affiliate fails to effectuate the cure described in Part 9K2 of Exhibit 5; or*

b. *The Criminal Activity is related to this CONTRACT or occurring in COUNTY.*

4. Limitations on Contractor Manager

No Contractor Manager may have previously been convicted of a Criminal Activity or any plea of "guilty," "nolo contendere," or "no contest" to a Criminal Activity.

5. Contractor Documentation

CONTRACTOR shall list all Contractor Managers in Contractor Documentation in Exhibit 3D.

L. Delay of Performance Obligations

Immediately upon learning that any actual or potential circumstance is delaying or threatening to delay the timely satisfaction of a Performance Obligation, CONTRACTOR shall give Director a Notice of the delay, including all relevant information, such as identifying the Performance Obligation, circumstance, and duration of the delay, and whether or not CONTRACTOR believes that the delay is due to Uncontrollable Circumstances. CONTRACTOR shall propose a solution for Director approval.

M. Subcontractors

CONTRACTOR shall not engage any Subcontractor in an amount exceeding \$50,000 for any individual Subcontractor without prior Director approval of the Subcontract and Subcontractor. CONTRACTOR is responsible for directing the work of CONTRACTOR's Subcontractors and any compensation due or payable to CONTRACTOR's Subcontractors is the sole responsibility of CONTRACTOR. CONTRACTOR shall remove any approved Subcontractor for good cause at Director's request. CONTRACTOR shall identify all Subcontractors in Contractor Documentation in Exhibit 3D. In its Annual Report, CONTRACTOR shall disclose to Director the name of all Subcontractors, the amount of Goods or Services that each Subcontractor provides to CONTRACTOR, and a description of CONTRACTOR's relationships to each Subcontractor (including ownership interests).

PART 10 - DEFINITIONS AND INTERPRETATION OF CONTRACT

A. Definitions

Defined words in this CONTRACT have the meanings given in Attachment 5-10A.

B. Interpretation and Construction

1. Gender and Plurality

Words of the masculine gender include correlative words of the feminine and neuter genders and vice versa. Words importing the singular number include the plural number and vice versa unless the context demands otherwise. (For example, reference to a defined "Solid Waste Facility" may include reference to more than one facility identified by CONTRACTOR in Contractor Documentation in Exhibit 3D.)

2. Headings; Font

Any captions or headings following the Exhibit, Attachment, Section, subsection, paragraph, and other attachments and subdivisions of this CONTRACT that precede the operative text of this CONTRACT are for convenience of reference only and do not control or affect the scope, intent, meaning, construction, interpretation, or effect of this CONTRACT. Any underlined, italicized, bold-faced, upper captioned or other font style is for ease of reading and contract administration only and does not imply relative importance or unimportance of any provision of this CONTRACT.

3. References to Parts

References to Sections refer to Sections of this CONTRACT, unless specified otherwise. References to Exhibits and Attachments refer to Exhibits and Attachments attached to this CONTRACT. Reference to "subsections" refers to the subsections contained in the same Section in which the reference occurs, unless otherwise referenced.

4. Examples

Examples are for purpose of illustration only. If any example is ambiguous, inconsistent, or conflicts with the text that it illustrates, the text governs.

5. Specifics No Limitation on Generalities

The mention of any specific duty or liability imposed on CONTRACTOR may not be construed as a limitation or restriction of any general liability or duty imposed on CONTRACTOR by this CONTRACT or Applicable Law.

6. Exhibits

The exhibits to this CONTRACT, including their attachments, are part of this CONTRACT to the same extent and effect as if included in the text of Sections 1 through 16.

7. Inconsistencies and Conflicts

- a.* If any provision of Exhibits 3A1, 3A2, or 3A3 is inconsistent or conflicts with Sections 1 through 16 or Exhibit 5 of this CONTRACT or any other Exhibits or Attachments to this CONTRACT, then the provisions of Exhibits 3A1, 3A2, and 3A3 will govern, and
- b.* If any provision of Sections 1 through 16 or Exhibit 5 of this CONTRACT is inconsistent or conflicts with any Exhibit (other than Exhibits 3A1, 3A2, or 3A3), including Contractor Documentation, then the provision of Sections 1 through 14 or Exhibit 5 of this CONTRACT will govern unless Director determines that it is contrary to the interest of the Parties.

C. Integration

This CONTRACT contains the entire CONTRACT between the Parties with respect to the rights and responsibilities of the Parties under this CONTRACT. This CONTRACT completely and fully supersedes all prior oral and written understandings and contracts between the Parties with respect to those rights and responsibilities.

D. Governing Law

This CONTRACT is governed by, and construed and enforced in accordance with the law of the State of California, without giving effect to the State's principles of conflicts of laws.

E. Severability

If any clause, sentence, provision, subsection, or Section of this CONTRACT or Exhibit to this CONTRACT (an "Contract Provision") is ruled illegal, invalid, nonbinding, or unenforceable by any court of competent jurisdiction, then the Parties will take the following actions:

- 1.** Promptly meet and negotiate a substitute for the CONTRACT Provision and any related amendments, deletions, or additions to other provisions of this CONTRACT, which together effect the Parties' original intent to the greatest extent allowable under Applicable Law; and

2. If necessary or desirable to accomplish preceding item 1, apply to the court that declared the invalidity for a judicial construction of the substituted CONTRACT Provision and any amendments, deletions, or additions to this CONTRACT. Within ten days of Director's request, CONTRACTOR shall pay COUNTY an amount equivalent to 100 percent of the Direct Costs of the application.

The illegality, invalidity, nonbinding nature, or unenforceability of any CONTRACT Provision will not affect any of the remaining provisions of this CONTRACT, and this CONTRACT will be construed and enforced as if the CONTRACT Provision did not exist.

F. Interpretation

This CONTRACT will be interpreted and construed neither for nor against either Party, regardless of the degree to which either Party participated in its drafting. CONTRACTOR acknowledges that it determined to provide Contract Services in the Service Area and to execute this CONTRACT upon CONTRACTOR's own choice and initiative. Each Party represents and warrants that it and its counsel have reviewed this CONTRACT, and the Parties agree that no provision in this CONTRACT will be construed against the drafting Party.

PART 11 - COMPLIANCE WITH LAWS AND REGULATIONS

A. Applicable Law

1. Compliance

CONTRACTOR shall secure and maintain all Permits, licenses, registration, agreements, and comply with all Applicable Laws, including (as required by 13 CCR 2021.1) all applicable air pollution control laws such as Diesel Particulate Matter Control Measure of on-road, heavy-duty, and the Property Tax Reduction Ordinance. No obligation in this CONTRACT may be construed to relieve CONTRACTOR of any obligations imposed by Applicable Law.

CONTRACTOR shall be fully responsible for possessing and keeping current and/or obtaining any required licenses/Permits from the appropriate Federal, State, or local authorities for work to be accomplished under this CONTRACT, including, but not limited to, a valid Waste Collector Permit issued by COUNTY Department of Public Health, Green Waste Quarantine Zone compliance agreement from California Department of Food and Agriculture, waste and used tire hauler registration from CalRecycle, and hazardous waste transportation Permit from CalRecycle.

CONTRACTOR shall secure and maintain valid waste and used tire hauler registration therefore in accordance with California Public Resources Code Section 42950 et seq. and any Permit required by Applicable Law for handling E-waste. CONTRACTOR shall transport tires to and Dispose of them at a facility authorized and permitted in accordance with Applicable Law to accept tires. CONTRACTOR shall comply with all applicable regulations governing the recovery of ozone-depleting refrigerants during the Disposal of air conditioning or refrigeration equipment, including 40 C.F.R. Part 82.

2. Referenced Provisions

References in this CONTRACT to provisions or requirements of Applicable Law may not be construed to limit CONTRACTOR's obligation to comply with all provisions of Applicable Law. Those references are intended to facilitate CONTRACTOR's satisfaction of its Performance Obligations and COUNTY's administration and specific enforcement of this CONTRACT and may not be construed to constitute lack of obligation to comply with other provisions or requirements of Applicable Law not specifically referred to or cited in this CONTRACT. If any provision of this CONTRACT is more stringent than Applicable Law, CONTRACTOR shall comply with that provision.

3. Fines and Penalties

CONTRACTOR is solely liable for all fines and penalties that may be imposed on CONTRACTOR or may be due to CONTRACTOR's actions, including fines and penalties that are the result of CONTRACTOR's Violation of Applicable Law (including Permits). CONTRACTOR shall not seek reimbursement from COUNTY, Customers, or Occupants for any fines or penalties.

4. Contractual Obligations

Provisions of Applicable Law are incorporated in this CONTRACT by reference as if set forth fully in this CONTRACT as contractual obligations of CONTRACTOR to COUNTY.

a. *Breaches*

In addition to or in lieu of prosecuting violations of those provisions as misdemeanors, infractions, or otherwise in the manner provided under Applicable Law, COUNTY may enforce those provisions in the same manner as it may enforce CONTRACTOR's other contractual obligations under this CONTRACT, including specific performance and as Breaches subject to cure in accordance with Part 6A of Exhibit 5. However, COUNTY has no obligation to enforce any Applicable Law.

b. *Violation*

Violation of Applicable Law is a Contractor Default subject to contest as provided in Part 6B4 of Exhibit 5.

5. COUNTY's Protection of Public Safety, Health, and Welfare

CONTRACTOR acknowledges that COUNTY is authorized to make all necessary and reasonable rules and regulations regarding all aspects of MSW Management Services to protect the public's health, safety, and welfare.

No provision in this CONTRACT is deemed to limit the power of COUNTY to regulate CONTRACTOR or to take any action as COUNTY deems appropriate or necessary in Director's sole and absolute discretion, under COUNTY's police power, including to protect the public's health, safety, and welfare.

6. Compliance with Applicable Law of COUNTY

CONTRACTOR shall comply with Applicable Law of COUNTY subject to possible adjustments in the Service Fees in the event of Changes in Law in accordance with items B, C, D, and E of Exhibit 7.

B. COUNTY Child Support Compliance Program

As required by COUNTY's Child Support Compliance Program (County Code Chapter 2.200), CONTRACTOR shall fully comply with employment and wage reporting requirements under the Federal Social Security Act (42 U.S.C. Section 653(a) and California Unemployment Insurance Code Section 1088.5. CONTRACTOR shall implement lawfully served wage and earnings withholding orders or COUNTY Child Support Services Department Notices of wage earnings assignment for child, family, or spousal support issued in accordance with California Code of Civil Procedure Section 706.031 and California Family Code Section 5246(b).

C. County Defaulted Property Tax Reduction Program

CONTRACTOR acknowledges that COUNTY has established a goal of ensuring that all individuals and businesses that benefit financially from COUNTY through contract are current in paying their property tax obligations (secured and unsecured roll) to mitigate the economic burden otherwise imposed upon COUNTY and its taxpayers.

Unless CONTRACTOR qualifies for an exemption or exclusion, CONTRACTOR warrants and certifies to the best of its knowledge under Attachment 5-9H, that as of the Execution Date it complies with County Code Chapter 2.206. Unless CONTRACTOR qualifies for an exemption or exclusion, CONTRACTOR shall comply with County Code Chapter 2.206.

PART 12 - LABOR-RELATED PROVISIONS REQUIRED IN COUNTY CONTRACTS

A. Labor Code

CONTRACTOR and its agents and employees are bound by and shall comply with all applicable provisions of the California Labor Code as well as all other Applicable Laws related to labor. By and through its execution of this CONTRACT, CONTRACTOR represents and warrants that it is aware of and understands the provisions of California Labor Code Section 3700, which requires every employer to be insured against liability of Workers' Compensation or to undertake self-insurance in accordance with those provisions before commencing the performance of work under this CONTRACT and agrees to fully comply with those provisions.

1. Consideration of Hiring GAIN/GROW Participants for Employment

Should CONTRACTOR require additional or replacement personnel after the effective date of this Contract, CONTRACTOR shall give consideration for any such employment openings to participants in COUNTY's Department of Public Social Services Greater Avenues for Independence (GAIN) Program and General Relief Opportunity for Work (GROW) Program who meet CONTRACTOR's minimum qualifications for the open position. For this purpose, consideration shall mean that CONTRACTOR will interview qualified candidates. COUNTY will refer GAIN and GROW participants by category to CONTRACTOR. CONTRACTORS shall report all job openings with job requirements to: GAINGROW@dpss.lacounty.gov and BSERVICES@wdacs.lacounty.gov and DPSS will refer qualified GAIN/GROW job candidates.

In the event that both laid-off COUNTY employees and GAIN and GROW participants are available for hiring, COUNTY employees shall be given first priority.

B. Notices to Employees

1. Regarding the Federal Earned Income Credit

CONTRACTOR shall notify its employees, and shall require each Subcontractor performing Contract Services to notify its employees, that they may be eligible for the Federal Earned Income Credit under the Federal income tax laws. The Notice must be provided in accordance with the requirements set forth in Internal Revenue Service Notice 1015 that CONTRACTOR has attached as Contractor Documentation.

2. Regarding Safely Surrendered Baby Law

CONTRACTOR acknowledges that COUNTY places a high-priority on the implementation of the Safely Surrendered Baby Law (SB 1368).

a. *Fact Sheet*

CONTRACTOR shall notify and provide to its employees and shall require each Subcontractor performing Contract Services to notify and provide to Subcontractors' employees a fact sheet regarding the Safely Surrendered Baby Law, its implementation in COUNTY, and where and how to safely surrender a baby. CONTRACTOR shall print and make available in every facility where its employees are present, including Offices and operation yards, the fact sheet that is available at www.babysafela.org.

b. *Poster*

CONTRACTOR understands that it is COUNTY's policy to encourage all COUNTY contractors to voluntarily post COUNTY's "Safely Surrendered Baby Law" poster in a prominent position at CONTRACTOR's place of business. CONTRACTOR shall also encourage its Subcontractors to post this poster in a prominent position in the Subcontractors' place of business. COUNTY's Department of Children and Family Services will supply CONTRACTOR with the poster to be used.

3. Regarding Child Support

CONTRACTOR acknowledges that COUNTY places a high priority on the enforcement of child support laws and the apprehension of child support evaders. CONTRACTOR further acknowledges that it is COUNTY's policy to encourage all COUNTY contractors to voluntarily post COUNTY's "L.A.'s Most Wanted: Delinquent Parents List" supplied by COUNTY in a prominent position at their place of business.

4. Time Off for Voting

CONTRACTOR shall notify its employees and shall require each Subcontractor to notify and provide to its employees, information regarding the time off for voting law (Elections Code, Section 14000). Not less than ten days before every Statewide election, every CONTRACTOR and Subcontractors shall keep posted conspicuously at the place of work, if practicable, or elsewhere where it can be seen as employees come or go to their place of work, a Notice setting forth the provisions of Section 14000.

C. Prohibition Against Use of Child Labor

1. Compliance with International Labor Organization Convention Concerning Minimum Age for Employment

CONTRACTOR shall not knowingly sell or supply to COUNTY or Customers and Occupants any products, goods, supplies, or other personal property manufactured in violation of child labor standards set by the International Labor Organization through its 1973 Convention Concerning Minimum Age for Employment (the "Convention Concerning Minimum Age for Employment"). If CONTRACTOR discovers that any products, goods, supplies, or other personal property sold or supplied by CONTRACTOR to COUNTY or any Customer are produced in violation of that Convention, CONTRACTOR shall immediately provide an alternative source of supply that complies with that Convention.

2. Provide COUNTY with Records

At COUNTY's request, CONTRACTOR shall provide documentation satisfactory to COUNTY evidencing the country or countries of origin of any products, goods, supplies, or other personal property CONTRACTOR sells or supplies to COUNTY or any Customer or Occupant relating to Contract Services.

3. Provide COUNTY with Manufacturers' Certification

At COUNTY's request, CONTRACTOR shall provide to COUNTY the manufacturer's certification of compliance with the Convention Concerning Minimum Age for Employment or other all-international child labor conventions.

D. Nondiscrimination

1. Employees

CONTRACTOR and its Affiliates shall employ qualified applicants and treat employees equally without regard to or because of race, color, national origin, ancestry, religion sex, age, physical or mental disability, marital status, or political affiliation and in compliance with all State of California and Federal antidiscrimination laws, including in employment, upgrading, demotion, transfer, recruitment, recruitment advertising, layoff, termination, Service Fees of pay, other forms of compensation, and selection of training (including apprenticeship).

2. Subcontractors, Bidders, and Vendors

CONTRACTOR shall deal with its Subcontractors, bidders, and vendors without regard to or because of race, color, national origin, ancestry, religion, sex, age, physical or mental disability, marital status, or political affiliation.

3. Certification

CONTRACTOR shall comply with the provisions of CONTRACTOR's EEO Certification (Form PW-7), attached as Contractor Documentation.

4. Inspection of Records

At COUNTY's request, CONTRACTOR shall Promptly allow COUNTY and its auditors or reviewer access to CONTRACTOR's employment Records at CONTRACTOR's Office during Contractor Office Hours to verify compliance with the provisions of Part 12D4 of Exhibit 5.

5. Remedies for Discrimination

If COUNTY finds that CONTRACTOR has violated any provisions of this subsection D, that violation constitutes a Contractor Default. While COUNTY reserves the right to determine independently that the antidiscrimination provisions of this subsection D have been violated, in addition, a determination by the California Fair Employment Practices Commission or the Federal Equal Employment Opportunity Commission that CONTRACTOR has violated State of California or Federal antidiscrimination laws will constitute a finding by COUNTY that CONTRACTOR has violated the antidiscrimination provisions of Part 12D of Exhibit 5.

E. Safety

1. Services Safety Official

CONTRACTOR shall designate in Contractor Documentation in Exhibit 3D a Services Safety Official who shall be thoroughly familiar with CONTRACTOR's Injury and Illness Prevention Program (IIPP) and Code of Safe Practices (CSP). CONTRACTOR shall ensure that the Services Safety Official is available always Contract Services are provided to abate any potential safety hazards. CONTRACTOR shall give the Services Safety Official the authority and responsibility to cease performing any service if necessary to abate any potential safety hazard. If CONTRACTOR fails to designate or make available the Services Safety Official, COUNTY may direct CONTRACTOR to cease providing Contract Services at no cost to COUNTY until CONTRACTOR complies with this Section.

2. Safety Responsibilities

CONTRACTOR is responsible for the safety of equipment, material, and personnel under CONTRACTOR's control or authority during performance of Contract Services. CONTRACTOR is solely responsible for ensuring that all work performed under this CONTRACT is performed in strict compliance with all Applicable Laws with respect to occupational safety regulations. CONTRACTOR shall provide at its expense all safeguards, safety devices, protective equipment, and shall take all actions appropriate to providing a safe job environment.

F. COUNTY Lobbyists

CONTRACTOR and each COUNTY lobbyist or COUNTY lobbying firm as defined in County Code Section 2.160.010, retained by CONTRACTOR shall fully comply with County Lobbyist Ordinance.

ATTACHMENT 5-9G – Authorized Representative of COUNTY's Director

Name: Steven E. Milewski

Telephone Number: (626) 458-3573

E-mail Address: SMilewski@DPW.LACounty.gov

Address for Notices by Mail:

County of Los Angeles Department of Public Works
Environmental Programs Division
P.O. Box 1460
Alhambra, CA 91802-1460

Director's Office Hours : 7 a.m. to 5:30 p.m. Monday - Thursday

Established by Director:

Signature: _____

Printed Name: _____

Date: _____

Acknowledged by CONTRACTOR:

Signature: _____

Printed Name: _____

Title: _____

Date: _____

ATTACHMENT 5-9H – CONTRACTOR's Representations and Warranties

A. Status

CONTRACTOR is duly organized, validly existing and in good standing under the laws of and is qualified to do business in the State of California with full power and authority to execute and deliver this CONTRACT and to perform its Performance Obligations. This CONTRACT has been duly executed and delivered by CONTRACTOR and constitutes a legal, valid, and binding obligation of CONTRACTOR enforceable against CONTRACTOR in accordance with its terms.

B. Statements and Information

All information and documentation compiled, drafted, made, or otherwise delivered to COUNTY by or on behalf of CONTRACTOR relating to this CONTRACT, including its procurement, is correct and complete in all material respects as of the Execution Date and at the time originally submitted by CONTRACTOR to COUNTY.

C. No Conflicts

Neither the execution or delivery by CONTRACTOR of this CONTRACT, the performance by CONTRACTOR of Contract Services, nor the fulfillment by CONTRACTOR of the terms and conditions of this CONTRACT: (1) conflicts with, violates, or results in a breach of any Applicable Law; (2) conflicts with, violates, or results in a breach of any Term or condition of any judgment, order or decree of any court, administrative agency or other governmental authority, or any CONTRACT or instrument to which CONTRACTOR is a Party or by which CONTRACTOR properties or assets are bound, or constitutes a default.

D. No Approvals Required

CONTRACTOR has obtained and maintains all Permits in full force and effect during the Term. No other approval, authorization, license, Permit, order, or consent of, or declaration, registration, or filing with any governmental or administrative authority, commission, board, agency, or instrumentality is required for the valid execution and delivery of this CONTRACT by CONTRACTOR, except those as have been duly obtained from its governing body, CONTRACTOR shall immediately provide Notice to Director of any Notice of violation, revocation, or suspension of any Permit.

E. No Litigation

As of the Execution Date, disclose any action, suit, proceeding, or investigation, at law or in equity, before or by any court or governmental authority, commission, board, agency or instrumentality pending or, to the best of CONTRACTOR's knowledge, threatened, against CONTRACTOR wherein an unfavorable decision, ruling or finding, in any single case or in the aggregate, would materially adversely

affect the performance by CONTRACTOR of its obligations under this CONTRACT or in connection with the transactions contemplated by this CONTRACT, or which, in any way, would adversely affect the validity or enforce ability of this CONTRACT or any other CONTRACT or instrument entered into by CONTRACTOR relating to the transactions contemplated by this CONTRACT.

F. Due Diligence

As of the Execution Date, CONTRACTOR has made an independent investigation, examination, and research satisfactory to it of the conditions and circumstances surrounding this CONTRACT and best and proper method of providing Contract Services and labor, equipment, and materials for the volume of Contract Services to be provided. CONTRACTOR agrees that it shall make no claim against COUNTY based on any estimates, statements or interpretations made by any officer, employee, agent, or consultant of COUNTY relating to the procurement of this CONTRACT, which proves to be in any respect erroneous.

G. Compliance with Applicable Law

As of the Execution Date, CONTRACTOR has fully complied with all Applicable Law, including (1) law relating to conflicts of interest and County Lobbyist Ordinance, while procuring this CONTRACT, and (2) County Defaulted Property Tax Reduction Program.

H. Ability to Perform

CONTRACTOR possesses the business, professional, and technical capabilities to provide Contract Services; and possesses the equipment, facilities, and employee resources required to fully and timely perform Contract Services.

I. Contingent Fees

No Person, including a selling agency, has been employed or retained to solicit or secure this CONTRACT upon a CONTRACT or understanding for a commission, percentage, brokerage, or contingent fee, excepting bona fide employees or bona fide established commercial or selling agencies maintained by CONTRACTOR for securing business.

J. Opportunity to Comment

CONTRACTOR had the opportunity to submit comments and recommended changes during the procurement process, during meetings convoked by COUNTY with the denominated "Working Group" whose members received copies of the drafts of the form of CONTRACT or during the procurement of this CONTRACT.

K. Solid Waste Facilities

1. The Solid Waste Facility or Facilities that CONTRACTOR designates in Contractor Documentation in Exhibit 3D for Disposal is a Disposal facility that is permitted to accept and Process Refuse in accordance with Applicable Law.
2. The facility or facilities that CONTRACTOR designates in Contractor Documentation in Exhibit 3D for delivery of Recyclables is a materials recovery facility that is permitted to accept and Process Recyclables in accordance with Applicable Law.
3. The facility or facilities that CONTRACTOR designates in Contractor Documentation in Exhibit 3D for delivery of Green Waste is a facility that is permitted to accept and Process Green Waste in accordance with Applicable Law.

L. Contractor Documentation

As of the Execution Date, CONTRACTOR has submitted all Contractor Documentation in accordance with Exhibit 3D.

M. Personnel

CONTRACTOR fully complies with all Federal and State statutes and regulations regarding employment of aliens and others, and all of its employees performing Contract Services meet the citizenship or alien status requirements set forth in Federal and State statutes and regulations.

ATTACHMENT 5-10A - Definitions

Abandoned Waste includes Solid Waste discarded or dumped at locations in Public Right of Way including palm fronds but excluding other materials dumped as the result of natural causes such as tree limbs or telephone poles blown over in a storm or walls collapsed during an earthquake.

AB 939 means the California Integrated Waste Management Act of 1989, California Public Resources Code Section 40000 et seq.

Additional Customer Services means all Performance Obligations prescribed in Exhibit 3A1 and Exhibit 3A3 that require a Customer Surcharge, including the more than once per week Collection frequency in item B3, more than one 96-gallon Refuse Container, or a locking Recyclables Cart.

Affiliate means a Person that, directly or indirectly through one or more intermediaries, controls, or is controlled by, or is under common control with CONTRACTOR.

Annual Report is described in item A3 of Section 10.

Applicable Law means all laws, statutes, rules, regulations, guidelines, Permits, actions, determinations, orders, or requirements of the United States, State of California, COUNTY, including its County Code together with rules and regulations promulgated there under and COUNTY's Integrated Waste Management Plan, the Local Enforcement Agency, California Highway Patrol, South Coast Air Quality Management District, and other regional or local government authorities, agencies, boards, commissions, courts, or other bodies having applicable jurisdiction, that from time to time apply to or govern Contract Services or the performance of the Parties' respective obligations under this CONTRACT, including those that concern health, safety, fire, mitigation monitoring plans, building codes, and zoning, and further including the following:

- Vehicles:
 - California Health and Safety Code Section 43000 et seq., with respect to air emissions (smog checks);
 - California Vehicle Code Section 27456b, with respect to tires;
 - California Vehicle Code Section 34500 et seq., with respect to documentation through its maintenance log or otherwise of a safety compliance report issued under Division 14.8 of the California Vehicle Code as applicable to each Vehicle, including bi-annual "BIT" inspections conducted by the California Highway Patrol;
 - Rules and regulations promulgated under the California Vehicle Code with respect to Vehicle highway lighting, flashing, and warning lights, clearance lights, and warning flags;
 - Rules and regulations of the California Department of Motor Vehicles with respect to Vehicle registration;
 - Vehicle weight limits;

- The appropriate class of drivers' licenses issued by the California Department of Motor Vehicles;
- Control Measure for Diesel Particulate Matter from On-road Heavy-Duty Residential and Commercial Solid Waste Collection Vehicles, 13 CCR 2020 et seq.; and
- 14 CCR 17341, 17342, 17343 and 17344, with respect to equipment construction, safety, and parking and identification of operating equipment;
- Containers:
 - 14 CCR 17314, with respect to maintenance and placement of Containers; and
 - 14 CCR 17317, with respect to placing identifying name and telephone number on Containers;
- Labor:
 - Drug and alcohol testing;
 - Occupational Safety and Health Act (29 U.S.C. Section 651 et seq.), including the Solid Waste Disposal Facility Criteria promulgated by the U.S. EPA on October 9, 1991 (40 C.F.R., Parts 257 and 258); and California Occupational Safety and Health Act (California Labor Code, Division 5, Parts 1-10, Section 6300 et seq.), and rules and regulations of California Division of Occupational Safety and Health; and
 - Immigration Reform and Control Act of 1986 (PL.99-603);
- Environmental Protection:
 - CERCLA;
 - RCRA;
 - Clean Air Act (42 U.S.C. Section 1351 et seq., 42 U.S.C. Section 7401-7642); and California Clean Air Act (California Health and Safety Code Section 39000 et seq.);
 - California Hazardous Waste Control Act (California Health and Safety Code Section 25100 et seq.);
 - California Hazardous Materials Release Response Plan and Inventory Act (California Health and Safety Code, Division 20, Chapter 6.95, Section 25500 et seq.);
 - Carpenter-Presley-Tanner Hazardous Substance Account Act (California Health and Safety Code Section 25300 et seq.); and
 - Emergency Planning and Community Right to Know Act (42 U.S.C. Section 11001 et seq.); and
- Miscellaneous:
 - County Lobbyist Ordinance;
 - County Defaulted Property Tax Reduction Ordinance.
 - Civil Rights Act of 1964 (Subchapter VI of Chapter 21 of Title 42);
 - AB 939; and
 - AB 1826.

Reference to Applicable Law includes future amendments and supplements to or replacement, restatement, or recodification thereof.

Authorized Commercial Waste Hauler means a waste hauler that has signed a Commercial Franchise agreement with COUNTY and is currently in good standing.

Award Date means the date County of Los Angeles Board of Supervisors approves the CONTRACT.

Basic Service means all Performance Obligations prescribed in Exhibit 3A1 and Exhibit 3A3 that do not require a Customer Surcharge, including the once per week Collection frequency in item B3 and the one 96-gallon Refuse, two 96-gallon Recyclables, and two 96-gallon Green Waste Containers in item D.

Basic Service Fee means the monthly charges that CONTRACTOR bills a Customer for providing Collection with respect to Task 1 Services, without additional optional services.

Best Efforts mean serious and sizeable efforts that a respectable Person would take in the same (or similar) circumstances, using principles of impartiality of fairness. It will be presumed that the Person intends to meet its obligations in honesty and good faith. Compare "Reasonable Business Efforts", "Reasonable"

Bilingual means in the languages of English and Spanish.

Board of Supervisors means the Board of Supervisors of County of Los Angeles.

Breach means CONTRACTOR's failure to fully and timely meet one or more Performance Obligations.

Bulky Item means any large item of Solid Waste that will not fit into the Container that can be safely lifted by two individuals using a dolly. A Bulky Item that has been placed at the Set-Out Site by the Occupant for Collection by CONTRACTOR, or for Customers with roll-out service, called in for Collection. A Bulky Item includes, but is not limited to the following:

- Discarded furniture (such as chairs, sofas, mattresses, and rugs);
- Large Appliances (such as refrigerators, ranges, washers, dryers, water heaters, dishwashers, and other similar items commonly known as "white goods");
- Up to two tires from passenger cars or pickup trucks;
- E-waste (such as computer, telephones, and televisions);
- Up to two bags/bundles of Construction and Demolition debris bound or in containers, not longer than four feet in length, up to 70 pounds in weight;
- Bagged reusable clothing;
- Palm fronds (not required to be cut to four-foot lengths).

Bulky Items excludes items such as:

- Large truck tires;
- Unpermitted Waste;
- More than two bags/bundles of Construction and Demolition debris;
- Piles of debris.

Calendar Year means the months beginning January 1 and ending December 31.

Cart means a wheeled Container provided by CONTRACTOR for storage of Solid Waste pending Collection, which is Collected (semi) by automated Vehicle. Examples include 32, 64, and 96-gallon plastic Containers.

CERCLA means the Comprehensive Environmental Response, Compensation, and Liability Act of 1982 (42 U.S.C. Section 9601 et seq.).

Change in Law means the occurrence of any event or change in Applicable Law as follows:

- The adoption, promulgation, modification, or change in Applicable Law or in judicial or administrative interpretation thereof occurring after the Execution Date other than laws with respect to taxes based on or measured by net income, or any unincorporated business, payroll, franchise taxes levied by any tax board (other than the Franchise Fees levied by COUNTY) or employment taxes;
- Any order or judgment of any Federal, State, or local court or Regulatory Agency issued after the Execution Date if:
 - That order or judgment is not also the result of the willful misconduct or negligent action or inaction of the Party relying thereon or of any third-Party for whom the Party relying thereon is directly responsible; and
 - The Party relying thereon, unless excused in writing from so doing by the other Party, will make or have made, or will cause or have caused to be made, Reasonable Business Efforts to contest that order or judgment (it being understood that the contesting in good faith of that an order or judgment will not constitute or be construed as a willful misconduct or negligent action of that Party);
- The imposition by a Regulatory Agency of any new or different material conditions about the issuance, renewal, or modification of any Permit after the Execution Date; or
- The failure of a Regulatory Agency to issue or renew, or delay in the issuance or renewal of, or the suspension, interruption, or termination of, any Permit after the Execution Date; if the failure to issue or the suspension or termination of any Permit is not the result of the willful misconduct or negligent action or inaction of the Party relying thereon or any third-Party for whom the Party relying thereon is directly responsible.

CNG Fuel Component means five percent of the Service Fee shown on the Customer Service Fee schedule times the percentage of Vehicles that use compressed natural gas.

Collect, Collection, or Collecting is defined in Exhibit 3A1 means Solid Waste pickup(s) made by CONTRACTOR required by and in accordance with this CONTRACT, including Abandoned Waste.

Commencement Date means the date defined in Item A of Section 2.

Commercial means related to a Person or thing that is not Residential or Multifamily.

Commercial Occupant means Person within the Service Area that occupies a Commercial Premise and receives services from CONTRACTOR.

Commercial Premises means Premises that are not Residential Premises or Multifamily Premises, including stores; offices; industrial plants; private schools; restaurants; rooming houses; hotels; motels; manufacturing, Processing, or assembly shops or plants; and hospitals, clinics, convalescent centers, and nursing homes (with respect to nonmedical waste only).

Compost means a mixture of decayed or decaying organic matter (such as leaves and grass) used to amend or fertilize soil.

Construction and Demolition (C&D) means material, other than hazardous waste, radioactive waste, or medical waste, that is generated by or results from construction or demolition-related activities including, but not limited to: construction, deconstruction, demolition, excavation, land clearing, landscaping, reconstruction, remodeling, renovation, repair, and site clean-up, as defined in County Code 20.87.030. C&D debris includes, but is not limited to: asphalt, concrete, brick, lumber, gypsum wallboard, cardboard and other associated packaging, roofing material, ceramic tile, carpeting, plastic pipe, steel, rock, soil, gravel, tree stumps, and other vegetative matter.

Container means any Cart or Dumpster used to provide Collection service.

CONTRACT means this CONTRACT, including all exhibits and other attachments, which exhibits and other attachments are incorporated in this CONTRACT by reference.

Contract Services means Task 1 and Task 2 Services together.

Contract Year means each 12-month period commencing on the first day of the month in which CONTRACTOR Collects Solid Waste from any Occupant.

CONTRACTOR means the Person executing this CONTRACT and any assignee of CONTRACTOR consented to by COUNTY in accordance with Section 19. CONTRACTOR includes CONTRACTOR's Subcontractors unless explicitly provided otherwise. References to all CONTRACTOR's actions and Performance Obligations under this CONTRACT include reference to Subcontractors' actions under this CONTRACT, as applicable, without specifying in each instance that CONTRACTOR shall directly take those actions itself, or cause its Subcontractors to take those actions on CONTRACTOR's behalf.

Contractor Default is described in Part 6 of Exhibit 5.

Contractor Documentation means documentation in Exhibit 3D.

Contractor Manager means any of the following:

- CONTRACTOR's officers and directors;
- The officers and directors of CONTRACTOR's parent corporation and of each successive parent corporation's parent corporation;
- The authorized representative of CONTRACTOR named in Contractor Documentation in Exhibit 3D; and
- Any other Persons, including Affiliates and CONTRACTOR's or Affiliates' employees, officers, or directors, in a Position of Influence.

Contractor Office Hours means 8:00 a.m. to 5:00 p.m. Monday through Friday, except Holidays.

Contractor's Related Parties means CONTRACTOR's partners, officers, directors, agents, employees, Subcontractors, consultants, licensees, invitees, and Affiliates.

Conversion Technology (CT) means an array of emerging technologies capable of converting the organic or carbon-containing materials portion of post-Recycling residual Solid Waste and turning it into useful products, including renewable and environmentally benign fuels, chemicals, and other sources of clean energy.

COUNTY means the government entity known as County of Los Angeles.

County Business Day means any day on which COUNTY's Department of Public Works is open to do business with the public.

County Code means the Los Angeles County Code.

County Defaulted Property Tax Reduction Program or County Defaulted Property Tax Reduction Ordinance means County Code Chapter 2.206.

COUNTY Lobbyist Ordinance means County Code Chapter 2.160.

County Service means the Task 2 Services from CONTRACTOR to the COUNTY.

County Service Fee means the amount that CONTRACTOR bills COUNTY for providing Collection with respect to Task 2 Services.

County Service Fee Schedule means the rates for CONTRACTOR's compensation for providing Task 2 Services.

County's Reimbursement Costs means Direct Costs of COUNTY plus 35 percent thereof.

County's Related Parties means political subdivisions, agencies, entities, or organizations for which the Board of Supervisors is the governing body, their agents, officers, and employees, elected officials, assigns, volunteers, and special districts

(including Garbage Disposal Districts) and each one of them. County's Related Parties are third-Party beneficiaries of provisions in this CONTRACT that reference them.

CPI means the Consumer Price Index for all Urban Consumers (Los Angeles-Riverside-Orange County) (Not Seasonally Adjusted) All items, Series ID CUURA421SA0, Base Period 1982-84=100, published by the United States Department of Labor, Bureau of Labor Statistics at <https://data.bls.gov/timeseries/CUURA421SA0>.

Criminal Activity means any of the following:

- Fraud or criminal felony offenses relating to obtaining, attempting to obtain, procuring, or performing a public or private CONTRACT related to Recyclables, Green Waste or MSW Management Services of any kind (including Collection, hauling, Transfer, Processing, Composting, or Disposal), including this CONTRACT;
- Bribery or attempting to bribe a public officer or employee of a local, State, or Federal agency;
- Embezzlement, extortion, racketeering, false claims, false statements, forgery, falsification or destruction of Records, obstruction of justice, knowingly receiving stolen property, theft, or misprision (failure to disclose) of a felony;
- Unlawful Disposal of hazardous, designated, or other waste; or
- Violation of securities laws or antitrust laws, including laws relating to price-fixing, bid rigging and sales and market allocation, and of unfair and anticompetitive trade practice laws, including with respect to inflation of Solid Waste Collection, hauling or Disposal fees.

Customer means a Person who pays either CONTRACTOR or COUNTY for Task 1 Services from CONTRACTOR.

Customer Service means the Task 1 Services from CONTRACTOR to the Customer.

Customer Service Fee means the amount that CONTRACTOR bills Customers for providing Task 1 Services.

Customer Service Fee Schedule is found in Attachment 7-2 to Exhibit 7.

Customer Surcharges means the amounts listed as "Surcharges" on the Service Fee Schedule.

Day means calendar day, whether capitalized or lower case.

Debarment or **Debar** has the meaning assigned in County Code Section 2.202.020.

Diesel Fuel Component means 5 percent of the Net Rate shown on the Rate Schedule times the percentage of Vehicles that use diesel.

Direct Costs means the sum of the following but excludes profit or return on investment:

- Payroll costs directly related to the performance, management, or supervision of any obligation under this CONTRACT, or exercise of any right, comprised of compensation and fringe benefits, including vacation, sick leave, Holidays, retirement, Worker's Compensation insurance, Federal and State unemployment taxes and all medical and health insurance benefits, plus;
- The costs of materials, services, direct rental costs, and supplies, plus;
- Travel and subsistence costs, plus;
- The reasonable costs of any payments to Subcontractors (with respect to CONTRACTOR) or contractors (with respect to COUNTY) or third Parties necessary to and about Performance Obligations, plus;
- Any other cost or expense which is directly or normally associated with the task performed; which is substantiated by:
 - A certificate signed by the principal financial officer of CONTRACTOR or the authorized representative of COUNTY setting forth the amount of that cost and the reason that cost is properly chargeable to COUNTY or CONTRACTOR and stating that the cost is a competitive price, if there are competitive prices, secured in an arm's length transaction for the service or materials supplied; and
 - If COUNTY or CONTRACTOR requests additional backup documentation as may be available to reasonably substantiate any Direct Costs, including invoices from suppliers, Subcontractors, and contractors.

Director means COUNTY Director of Public Works or his or her authorized representative, including the authorized representative named in Attachment 5-9G.

Director's Office Hours means hours that Director is open to do business as indicated in Attachment 5-9G.

Disabled means Occupants who suffer from a disability as evidenced by a letter from their medical physician.

Disposal or **Dispose** means Disposal, as defined in California Public Resources Code Section 40192, at a Solid Waste Facility of Refuse that CONTRACTOR has Collected.

Disposal Component means 20 percent of the Customer Service Fee shown on the weighted adjustments of item A3 of Exhibit 7.

District means Garbage Disposal District.

Diversion or **Divert** means activities that reduce or eliminate the amount of Solid Waste from Disposal for the purposes of Division 13 of the California Public Resources Code, including Article 1 (commencing with Section 41780).

Diversion Goal means the current State law requirement of 50 percent, the State goal of 75 percent Diversion by 2020, and future COUNTY goals including the Roadmap to a Sustainable Waste Management Future adopted by the Board of Supervisors on April 22, 2014. The Roadmap goals are 80 percent Diversion from landfills by 2025, 90 percent

Diversion from landfills by 2035, and 95 percent or more Diversion from landfills by 2045, as calculated by Director using Director's methodology. State and COUNTY goals are subject to change.

DOE CNG means the West Coast Average Price for Fuel – Compressed Natural Gas Average Prices by Region from Clean Cities Sources, published quarterly in Energy Efficiency and Renewable Energy/Clean Cities Alternative Fuel Price Report from the United States Department of Energy website, www.afdc.energy.gov/fuels/prices.html or if that is permanently discontinued, another CNG price published by a State or the Federal government selected by Director.

DOE Diesel means the Diesel (On Highway) – Product/All Types for Area/California (Period: Annual) price published monthly in the Energy Statistics from the United States Department of Energy website http://tonto.eia.doe.gov/dnav/pet/pet_pri_gnd_dcus_sca_m.htm, or if that is permanently discontinued, Producers Price Index- Commodities Fuels and related products and power/No.2 diesel fuel Series Id: WPU057303 published by the United States Bureau of Labor Statistics at <http://data.bls.gov/cgi-bin/surveymost>.

Dumpster means a container for storage of Solid Waste that is usually Collected with front end loading Vehicles, such as those having a 1 to 8-cubic yard capacity, commonly referred to as a Dumpster.

EIA LNG means the average for fuel – Product/All Types for Area/California (Period: Annual) price published monthly in the Official Energy Statistics from the United States Energy Information Administration website, http://tonto.eia.doe.gov/dnav/ng/ng_pri_sum_dcu_SCA_m.htm, or if that is permanently discontinued, another CNG price published by the State of California or the Federal government selected by Director.

Elderly means a Person age 62 or older as evidenced by a driver's license or other document issued by a governmental entity.

E-waste means waste that is powered by batteries or electricity, such as computers, telephones, stereo equipment, DVD players/recorders, mp3 players, televisions, and calculators.

Excess Solid Waste means bagged, containerized, or bundled Solid Waste, not to exceed 4 feet in length or 70 pounds in weight.

Execution Date means the date this CONTRACT is signed by both COUNTY and CONTRACTOR.

Expected Number means a quantity that Director anticipates during a future Contract Year plus 10 percent, based on the previous year's data.

Expiration Date means the date this CONTRACT expires as provided in accordance with item A of Section 2.

Fiscal Year means the 12-month period beginning July 1st and ending the following June 30th.

Food Waste means uneaten materials acquired for animal or human consumption.

Garbage Disposal District means a district created under County Code Chapter 20.90 and referred to as COUNTY in this CONTRACT.

Goods or Services means goods or services used in providing Contract Services, including labor; leases; subleases; equipment; supplies; capital; insurance, bonds, or other performance security if the insurer, surety, or other provider is an Affiliate or a captive of CONTRACTOR or any Affiliate; and legal, risk management, general, and administrative services.

Green Waste means Solid Waste comprised of leaves, grass clippings, brush, branches, nonhazardous wood waste, and other forms of organic matter generated from landscapes and gardens and separated from other forms of Solid Waste, including Holiday trees and bushes, but excluding:

- Stumps or branches exceeding four inches in diameter or four feet in length;
- Yucca or palm fronds, unless CONTRACTOR can Divert those excluded materials in non-Composting processes;
- Other Director-approved items listed in the Terms and Conditions; and
- Food Waste.

Gross Receipts means fees, charges, and other compensation that CONTRACTOR or Contractor's Related Parties receive directly or indirectly from Customers and Occupants about Task 1 Services before any deduction for costs or expenses such as the Franchise Fee. Gross Receipts does not mean fees, charges, and other compensation that CONTRACTOR or Contractor's Related Parties receive about the sale of Recyclables.

Holidays means January 1, Memorial Day, 4th of July, Labor Day, Thanksgiving, and December 25 and any other Holidays designated by COUNTY in Notice to CONTRACTOR.

Homeless Encampment means an area where more than three individuals are living nearby each other in temporary shelters, tents, Recreational Vehicles, or other means provided in COUNTY policy.

Including or Include or variations thereof, when used in this CONTRACT, means "including without limitation," "including, but not limited to," and "including, at a minimum."

Indemnities or Indemnification means all defenses, Indemnities, and releases under this CONTRACT, including under Part 4A of Exhibit 5 (generally), and with respect to the Immigration Reform and Control Act and Cal/OSHA (specifically).

Liabilities mean any of the following:

- Liabilities;
- Lawsuits;
- Claims;
- Complaints;
- Cause of actions;
- Citations;
- Investigations;
- Judgments;
- Demands;
- Cleanup orders;
- Damages (whether in contract or tort, including:
 - Personal injury to or death of, at any time, CONTRACTOR's employees, Subcontractors, COUNTY employees or third Parties; and
 - Property damage of CONTRACTOR, Subcontractors, COUNTY employees or third Parties);
- Costs and expenses, (including all costs and expenses of litigation, mediation or arbitration, attorneys' fees, whether COUNTY'S or CONTRACTOR's staff attorneys or outside attorneys, and court costs);
- Losses;
- Fines;
- Penalties; and
- Other detriments of every nature and description whatsoever, whether under State of California or Federal law.

LNG Fuel Component means five percent of the Customer Service Fee shown on the Service Fee Schedule times the percentage of Vehicles that use liquid natural gas.

Local Enforcement Agency means the enforcement agency defined in County Code Section 20.56.030.

Manure means Solid Waste comprised of animal dung or excrement and may include straw or other absorbent.

Maximum Rate Adjustment is described in Section A4 of Exhibit 7.

Monthly Report is described in item A1 of Section 10.

More Than Expected Number means a quantity greater than what Director anticipates during a future Contract Year; it is the quantity between the Expected Number and up to double the Expected Number.

Mulch means organic materials commonly used for Mulch including wood chips, ground up landscape trimmings, shredded bark, coarse Compost material, and straw.

Multifamily means Person or thing related to (1) dwellings with three or more attached dwelling units (such as apartments), each with separate cooking and bathing facilities, (2) townhouses, and (3) condominiums, whether attached or detached.

Multifamily Occupant means Person within the Service Area who occupies a Multifamily Premises and receives services from CONTRACTOR.

Multifamily Premises means Premises containing a Multifamily building.

Municipal Solid Waste (MSW) Management Services means any of the following:

- Collection, transportation, storage, Transfer, or Processing of:
 - Solid Waste; or
 - Unpermitted Waste that is Collected as part of a Collection program for Bulky Items, and E-waste described in Exhibit 3A1 and handled in accordance with Applicable Law (such as tires more than load limits, and certain E-waste); or
- Arranging for disposal of that Solid Waste or Unpermitted Waste.

Non-Collection Notice means the Notice in the form included in Contractor Documentation in Exhibit 3D in accordance with item C of Section 4.

Notice (when capitalized) means Notice given in accordance with Part 9F of Exhibit 5.

Occupant means a Person within the Service Area that occupies a Residential or Commercial building and receives services from CONTRACTOR.

Office means CONTRACTOR's offices required by item A of Section 6 to be identified in Contractor Documentation in Exhibit 3D.

Organic Waste or Organics means both of the following:

- Organic waste defined in AB 1826, and
- Organic waste used in portions of AB 1383 selected by Director and Noticed to CONTRACTOR, and includes Food Waste and Green Waste.

Party or **Parties** means COUNTY and CONTRACTOR, individually and together, respectively.

Performance Obligations means every obligation and liability of CONTRACTOR under this CONTRACT.

Permit means any Federal, State, County, other local, and any other governmental unit Permit, order, license, approval, authorization, consent, or entitlement of whatever kind and however described that Applicable Law requires to be obtained or maintained with respect to the satisfaction of Performance Obligations, as renewed or amended from time to time, including the waste collector Permit issued by the Los Angeles COUNTY Department of Public Health.

Person means any individual, firm, association, organization, partnership, corporation, trust, joint venture, State, County, municipality, special purpose district, the United States or any other entity.

Position of Influence means a position of authority or responsibility to directly or indirectly administer, manage, direct, supervise or oversee the Contract Services or this CONTRACT, including the following: (1) serving as director of the board of directors of CONTRACTOR or an Affiliate, (2) serving as an officer of CONTRACTOR or an Affiliate, (3) reviewing or negotiating CONTRACTOR's contracts (including this CONTRACT), (4) providing in-house legal services, and (5) providing insurance or other performance security if the provider is an Affiliate or is a captive of CONTRACTOR or an Affiliate; but excluding the following: (1) monitoring CONTRACTOR's performance, (2) supervising CONTRACTOR's finance and capital budget decisions, and (3) articulating general policies and procedures not related to a Criminal Activity.

Premises means a tract of land located in the Service Area which is safely accessible by Vehicles.

Processing or Process means the reduction, separation, recovery, conversion, or Recycling of Solid Waste, including creating "compost" as defined in California Public Resources Code Section 40116.

Prompt or Promptly means as soon as practicable, but in no event more than two days unless otherwise agreed by Director, Customer, or Occupant.

Public Right-of-Way or Right-of-Way includes all the following:

- all land and improvements on that land between the outer edge of a sidewalk (nearest to a private lot) on one side of the street and the outer edge of the sidewalk (nearest to a private lot) on the opposite side of the street, including:
 - sidewalks,
 - and between a sidewalk and street, and
 - median strips in the center of streets.
- Public streets;
- Public alleys, including land wall-to-wall and fence-to-fence, and
- Any other land described by COUNTY to CONTRACTOR.

Quarterly Report is described in item A2 of Section 10.

RCRA means the Resource Conservation and Recovery Act (42 U.S.C. Section 6901 et seq.).

Reasonable or Reasonable Business Efforts or Reasonable Efforts or Reasonable Judgment means practical actions a sensible person would do in the same (or similar) circumstances using sound judgment and principles of fairness. It will be presumed that the Person intends to meet its obligations in honesty and good faith. It does not mean pursuing every possible action.

Records means documentation relating to Contract Services and other Performance Obligations, including ledgers, books of account, invoices, vouchers, canceled checks, logs, correspondence, computations, files, plans, correspondence, Reports, drawings, designs (other than those respecting facilities or facility operations not involving Collection), data and photographs prepared by or possessed by CONTRACTOR, including the following:

- Customer and Occupant Terms and Conditions and Task 1 Services information (including Customers and Occupants' names and addresses), billing Records, call logs, route maps, schedules, and correspondence with Customers and Occupants;
- Weight tickets, invoices, bills of lading, and receipts from Solid Waste Facilities for types and amounts of Solid Waste that CONTRACTOR Collects, transports, and delivers to those Solid Waste Facilities;
- Records for AB 939 and other laws, including documentation from Recyclables and Green Waste transporters, shippers, brokers, beneficiaries, remanufacturers, and purchasers or other users of Recyclables and Green Waste; any Reports on Processing of Recyclables or Green Waste residual that Solid Waste Facilities may make to the CalRecycle;
- Vehicle maintenance, driver Permits and driver testing Records;
- Gross revenues and receipts, including Gross Receipts;
- the Franchise Fees paid to COUNTY; and
- Records that may be relevant in the event of an action under CERCLA or similar claims.

Recyclables is also defined in Item G of Exhibit 3A1 and means Solid Waste that may potentially be Diverted from Disposal (excluding Green Waste and Manure) including but not limited to any of the following materials:

- Aluminum and metal cans;
- Newspaper;
- Glass jars and bottles;
- Tin cans;
- Plastic soda bottles;
- Plastic milk and water jugs;
- Plastic bags (e.g., bread, frozen food, grocery bags);
- Type No. 1 plastic containers (PET-polyethylene terephthalate);
- Type No. 2 plastic containers (HDPE-high density polyethylene);
- Type No. 3 plastic (PVC-Vinyl or Polyvinyl Chloride);
- Type No. 4 plastic (LDPE-Low Density Polyethylene);
- Type No. 5 plastic (PP-Polypropylene);
- All types of paper (e.g., office paper, junk mail, magazines, telephone books);
- Corrugated cardboard;
- E-waste;
- White goods (such as those listed in the definition of Bulky Items);
- Paper coated with plastic or aluminum foil (milk and juice cartons); and
- Mattresses, excluding those made mostly of foam.

Additional (or deleted) items that Director directs after Notice to CONTRACTOR, without adjustment of Service Fees unless the modification requires Contract Services at the Set-Out Sites separate and distinct from previously Collected Recyclables.

Recycle or Recycling means the Process of Collecting, sorting, cleansing, treating, and reconstituting materials (including Recyclables and Green Waste) that would otherwise become Solid Waste and returning them to the economic mainstream in the form of raw material for new, reused, or reconstituted products that meet the quality Standards necessary to be used in the market place. Recycling does not include transformation, as defined in California Public Resources Code Section 40201.

Refuse means Solid Waste that CONTRACTOR does not Divert.

Refuse Unit means a number of units assigned to each parcel of real property based on land use codes as shown by current Records of COUNTY Assessor. See Exhibit 16 for the number of Refuse Units assigned to each Property Use Classification.

Regulatory Agency means any Federal, State or local governmental agency that regulates Collection and transportation of Solid Waste (including California Department of Transportation, California Department of Motor Vehicles, EDD, U.S. Immigration and Naturalization Services, or other health and safety department thereof; COUNTY; and Local Enforcement Agency applicable to Contract Services).

Report means Monthly Report, Quarterly Report, Annual Report and any AB 939 or other report CONTRACTOR is required to submit in accordance with this CONTRACT.

Residential means Person or thing related to detached, single-family homes or duplexes, other than condominiums or townhouses.

Residential Occupant means Person within the Service Area who occupies a Residential Premises and receives services from CONTRACTOR.

Residential Premises means Premises containing a Residential building, such as a detached, single-family home or a duplex.

Service Area means the area mentioned in the title of this CONTRACT, as described in item A1 of Section 16.

Service Assets means all property of CONTRACTOR used directly or indirectly in performing Contract Services, including Vehicles, Containers, maintenance equipment and facilities, and administrative equipment and software, both tangible and intangible (such as facility leases or equipment installment purchase contracts).

Service Day means any day Monday through Friday, excluding Holidays.

Service Component means 65 percent of the Service Fee shown on the Customer Service Fee.

Service Fees means both Customer Service Fees (Task 1) and County Service Fees (Task 2).

Service Fee Schedule means all the fees listed in Attachments 7-2 and 7-3 of Exhibit 7.

Service Specifications means Performance Obligations prescribed in Exhibit 3A1 and Exhibit 3A2.

Service Standards means each obligation of CONTRACTOR prescribed in Section 4.

Set-Out Site means the location where the Solid Waste is temporarily placed for Collection as mutually agreed upon by CONTRACTOR and Occupant.

Sharps means any item having corners, edges, or projections capable of cutting or piercing the skin to deliver injections or for medical purposes, such as needles (hypodermic, pen or intravenous), needles with syringes, needles from vacutainers, needles with attached tubing, and lancets.

Sharps Containers means Container approved by COUNTY for discard of Sharps.

Solid Waste means Solid Waste as defined in California Public Resources Code Section 40191, excludes Unpermitted Waste but includes all the following:

- Green Waste,
- Recyclables,
- Refuse,
- E-waste,
- Organics,
- Manure, and
- Abandoned Waste.

Solid Waste Facility means the facility as defined in California Public Resources Code Section 40194 (and any other types of facilities named by Director) and designated by CONTRACTOR in Contractor Documentation in Exhibit 3D.

Standards means the criterion for excellent Solid Waste management established by the solid waste collection industry; professional associations such as the National Solid Waste and Recycling Association, Solid Waste Association of North America, US Mayors/ Municipal Solid Waste Association; and public bodies such as State and Federal EPAs.

Subcontractor means any Person that provides Goods or Services related to Collection, transportation or storage of Solid Waste or related to Service Assets, including their operation, maintenance, and repair, to or on behalf of CONTRACTOR whether pursuant to any arrangement, formal or informal, written or merely in practice. Subcontractor does

not include a Person that provides Goods or Services related to Processing, Diversion, or Disposal, nor the manufacturer that provides equipment.

Sweep means to search the specified area; Collect, transport, and Dispose of Solid Waste not in Containers.

Task 1 Services all Performance Obligations prescribed in Exhibit 3A1 and Exhibit 3A3 for Refuse, Recyclables, and Green Waste Container services to Occupants at Residential Premises and Certain Multifamily and Commercial Premises.

Task 2 Services means all Performance Obligations prescribed in Exhibit 3A2 Abandoned Waste Collection services and Public Receptacle Collection services.

Term means the period beginning on the Execution Date and ending on the Expiration Date and is also defined in item A of Section 2.

Terms and Conditions means the CONTRACT details mailed to Customers and Occupants.

Ton or Tonnage means a short ton of 2,000 pounds avoirdupois.

Transfer is defined in Part 8 of Exhibit 5.

Uncontrollable Circumstances means any of the following events:

- Riots, war, or emergency affecting the Country declared by the President of the United States or Congress of the United States, the Governor of California, or the Board of Supervisors;
- Sabotage, civil disturbance, insurrection, explosion;
- Natural disasters such as floods, earthquakes, landslides, and fires;
- Strikes, lockouts, and other labor disturbances; or
- Other catastrophic events that are beyond the reasonable control of CONTRACTOR despite CONTRACTOR's exercise of due diligence, excluding:
 - The financial inability of CONTRACTOR to satisfy its Performance Obligations, or
 - Failure of CONTRACTOR to obtain any necessary Permits or the right to use the facilities of any public entity.

Universal Waste means hazardous waste that the California Department of Toxic Substances Control considers Universal Waste, including materials listed in 22 CCR 66261.9, such as batteries, thermostats, lamps, cathode ray tubes, computers, telephones, answering machines, radios, stereo equipment, tape players/recorders, phonographs, video cassette players/recorders, compact disc players/recorders, calculators, some appliances, aerosol cans and certain mercury-containing devices.

Unpermitted Waste means

- Materials that are not Solid Waste such as Universal Waste, household hazardous waste and other hazardous waste, unauthorized medical waste, radioactive waste;
- Waste tires more than the limitations prescribed in 14 CCR 17355(b) or reduced in volume as required in 14 CCR 17355(A);
- Any other materials that cannot be Disposed of in class II sanitary landfills described in 27 CCR 20250.

Unpermitted Waste Screening Protocol means the protocol prescribed in Section 13, Item A of Exhibit 5 and included in Contractor Documentation in Exhibit 3D.

Vehicle means any truck used by CONTRACTOR to provide Contract Services.

Violation of Applicable Law means any noncompliance with Applicable Law as evidenced by Notice, assessment, or determination of any Regulatory Agency to CONTRACTOR, whether a fine or penalty is included, assessed, levied, or attached.

Weighted Customer Service Fee Adjustment Percentage means sum of the adjustments due to changes in the CPI, DOE CNG, EIA LNG, and Disposal tipping fees calculated as provided in items B, C, and D of Exhibit 7, respectively.

EXHIBIT 7 – Contract Services (Adjustment of Service Fees)

A. Service Fee Schedule

CONTRACTOR shall charge Service Fees (Customer Service Fees and County Service Fees) in amounts less than or equal to the Service Fees set forth in the Service Fee Schedule in Attachments 7-2 and 7-3 of this Exhibit.

1. Time, Conditions, Changes

a. Annual Adjustments

(1) Automatic (Indices):

Beginning at least 6 months after the Commencement Date, Director will automatically adjust the Consumer Price Index (CPI), Department of Energy (DOE) Compressed Natural Gas (CNG), or Energy Information Agency (EIA) Liquefied Natural Gas (LNG) components of the Service Fee each July 1 in accordance with subsections A1 a(3), B, C and D.

(2) Requested (Disposal and Diversion):

Beginning at least 12 months after the Commencement Date, Director will adjust the Disposal and Diversion components of the Service Fee each July 1 in accordance with subsection A1a (3) and E in the following events:

- CONTRACTOR requests adjustment of those components by Notice to Director together with documentation satisfactory to Director by March 1 of each year, and
- COUNTY initiates an adjustment of those components by Notice to CONTRACTOR together with documentation satisfactory to Director by March 1 of each year.

(3) Changes:

Director will adjust the Service Fee for the following changes, if any:

- **Indices (After 6 Months):** Annual changes, if any, in the following indices, as applicable, defined in Attachment 5-10A:

- CPI: Consumer Price Index (CPI),
- **DOE CNG:** of Energy (DOE) Compressed Natural Gas (CNG), or
- **EIA LNG:** Energy Information Agency (EIA) Liquefied Natural Gas (LNG)

in accordance with the Service Fee adjustment protocol in subsections B, C, and D; or

- **Disposal Tipping Fees (after 12 Months):** Annual change, if any, in CONTRACTOR's Direct Costs of Refuse Disposal, such as changes in publicly-posted tipping fees, on January 1 at the Solid Waste Facility it has designated in Contractor Documentation, Exhibit 3D, and any other supporting documentation, submitted to Director by March 1; or
- **Disposal or Diversion of Green Waste (after 12 Months):** Annual changes in CONTRACTOR's costs of Disposal or Diversion of Green Waste, such as public tipping fees, on January 1 from the Solid Waste Facility it has designated in Contractor Documentation in Exhibit 3D, and any other supporting documentation, submitted to Director by March 1.

b. Adjustments at Any Time

If CONTRACTOR requests Director by Notice or Director Notifies CONTRACTOR at any time, following agreement with CONTRACTOR, the Director may adjust the Service Fees in either of the following events, subject to changes in Refuse Disposal or Green Waste Diversion in subsection A4, and limitations in A6:

(1) Changes in Law

Change in CONTRACTOR's Direct Costs of providing Contract Services due to Changes in Law. Any adjustment in the Service Fee due to a Change in Law by the State is not included in the Maximum Rate Adjustment in subsection 4.

(2) Changes in Scope of Service

Up to ten percent of CONTRACTOR's Direct Costs of providing Contract Services due to changes in Contract Services or Standards.

If CONTRACTOR and Director disagree on the adjustment of Service Fees due to Changes in Law, or changes in Contract Services or Standards, COUNTY will have the option to terminate this CONTRACT in accordance with Part 6D of Exhibit 5.

c. No Adjustment

Service Fees will not be adjusted:

- Within six or twelve months of the Commencement Date with respect to item A1a(1) and items A1a (2-3) respectively.
- During any of the six possible one-month extensions under item A3 of Section 2.
- If there are any uncured Breaches.
- For Changes other than changes explicitly listed in preceding subsections a and c, including for actual changes in the price of fuel.

d. Sample Calculation

A sample calculation is attached in Attachment 7-1 of this Exhibit.

2. Rounding

All calculations are rounded to the nearest 1/100th decimal place (for example, 10.9656 percent to 10.97 percent, or 10.9637 percent to 10.96). The decimal 5 is rounded up (for example, 10.965 percent to 10.97 percent). Adjustments in Service Fees are rounded to the nearest penny (for example, \$25.34).

3. Weighted Adjustment

a. Serviced Fee Components

The monthly Service Fees for Contract Services will be divided into the following cost components and adjusted by these percentages:

Labor (and other general costs of Contract Services)	65%
Fuel	5%
Refuse Disposal	20%
Green Waste	10%
Organics Disposal and Diversion:	0%
• Green Waste	
• Food Waste	
Food Waste Diversion-only	0%
Recyclables Diversion	0%

A sample calculation is attached in Attachment 7-1 of this Exhibit.

b. *Modifications in Weight of Disposal/Diversion Components*

COUNTY acknowledges that CONTRACTOR's costs of providing Disposal and Diversion may change significantly. Before each July 1, Director will review Service Fees under its contracts that are substantially like this CONTRACT, including contracts for Residential Collection service with Carts. In its sole discretion, COUNTY may adjust (or refrain from adjusting) the following components' related percentage:

- **Refuse Disposal** percent, and
- **Green Waste Diversion** percent.

For example, if Green Waste Diversion costs rise, the Director might make the following adjustments:

- Increase Green Waste Diversion percentage from 10 percent to 12 percent for both the Santa Monica Mountains and Avocado Heights even though those costs were different in the two Service Areas; and
- Correspondingly decrease the Disposal percent from 20 percent to 18 percent.

Director will not make an adjustment solely to this CONTRACT but not in other, similar contracts.

Director will not modify the weighted 65 percent labor or 5 percent fuel components of the Service Fee.

A sample modification is attached to this Exhibit as Attachment A3(4).

4. Maximum Rate Adjustment

Cumulative adjustments to the Service Fees cannot exceed the percentages in the following table, except for changes due to acts of the State:

Contract Period (on July 1) *	Maximum Cumulative Adjustment**
Years 0 to 1 (Commencement Date to the first July 1)	0 percent
Years 2 to 7 (The first July 1 to the scheduled Termination Date under Section 2)	35 percent
Years 8 to 9 / Extension No. 1, if any	45 percent

(July 1 of any first 2-year extension to June 30 on the extended Termination Date)	
Years 10 to 11 / Extension #2, if any (July 1 of any 2-year extension to June 30 further extended Termination Date)	55 percent
Any time (Changes in direct costs due to Change In Law by the State)	Actual Direct Costs
Six 1-month extensions, if any	No Change

- * Rate adjustments due to Changes in Laws or Contract Services under subsection A1 above may be implemented at any time during the Term.
- ** Any change in Service Fees for direct costs due to Changes in Law promulgated by the State are not included in the percentage calculations of the Maximum Cumulative Service Fee Adjustment. They are added to the percentage calculations.

For example, during the first seven years of the CONTRACT, the Service Fee could increase 35 percent plus an allocable amount due to an increase of \$4 per Ton on the State-mandated Disposal fee.

5. Customer 30-Day Notice

CONTRACTOR shall provide all Customers a minimum of 30-days written Notice of the implementation of changes in any Customer Service Fees.

6. Adjustment Limitations

No adjustment will be effective until Notice thereof has been provided to the Board of Supervisors. Service Fees will be adjusted only if there are no uncured Breaches.

While COUNTY will automatically adjust the CPI and fuel components, adjustments to the Disposal and Diversion components requires the submittal of documentation by March 1 of each year. Failure to submit data will result in no adjustment to either the Disposal or Diversion components, or both.

Service Fees will not otherwise be adjusted, including for actual changes in the price of fuel or increases in Disposal tipping fees other than as described in the preceding items of this item B1 of this Exhibit.

If CONTRACTOR and Director fail to reach CONTRACT to adjust the Service Fees because of Changes in Law or changes in Contract Services or Standards described below, COUNTY will have the option to terminate this CONTRACT in accordance with Part 6D of Exhibit 5.

7. Services Eligible for Adjustment

a. *Customer Service Fee (CPI, Fuel, and Disposal/Diversion)*

Use methodology in items C, D, E, and F of Exhibit 7.

b. *Bear-Resistant Cart Fee (CPI)*

Use methodology in item C of Exhibit 7.

c. *Locking Recyclables Cart Fee (CPI)*

Use methodology in item C of Exhibit 7.

d. *Recyclables*

There is no adjustment for Recyclables at this time. However, Director may include a Director determined adjustment at any time in the future, at Director's sole discretion. A reason for an adjustment may include a significant change in the value of a commodity such as mixed paper.

e. *County Service Fee (Task 2)*

Use methodology in items C, D, E, and F of Exhibit 7.

B. This item is no longer used

C. Service Fee Adjustment for Annual Increase or Decrease in CPI

Beginning on or after six months have elapsed from the Commencement Date to July 1 of the current year, the CPI component of the Service Fee will be adjusted by 100 percent of the percent change, if any, between the following:

- The monthly average CPI during the 12-month period commencing March 1 of the previous year to the last day of February of the current year, and
- The monthly average CPI during the 12-month period commencing March 1 of the next previous year to the last day of February of the previous year.

For example, a contract that started April 1, 2018, will not be eligible for a rate adjustment for CPI on July 1, 2018. On July 1, 2019, the rate adjustment would compare March 1, 2018 through February 28, 2019, to March 1, 2017, through February 28, 2018.

However, under COUNTY regulations, any percentage change shall not exceed the general salary movement granted to COUNTY employees as determined by COUNTY's Chief Administrative Office as of July 1 for the prior Fiscal Year. Furthermore, should fiscal circumstances ultimately prevent the Board from

approving any change in COUNTY employee salaries; no cost-of-living adjustment will be granted.

D. Service Fee Adjustment for Annual Increase or Decrease in Fuel

A minimum of 6 months must elapse between Commencement Date and July 1 of the current year. The DOE CNG component of the Service Fee adjustment will apply only to the percentage of Vehicles in a fleet that use compressed natural gas. The adjustment of the DOE LNG component will apply only to the percentage of Vehicles in a fleet that use CNG or LNG. The adjustment of the DOE Diesel component will apply only to the percentage of Vehicles in a fleet that uses diesel.

1. Adjustment Due to Change in DOE CNG

The CNG Fuel Component of the Service Fees will be adjusted by the percent change, if any, between the following:

- The DOE CNG quarterly averages commencing in January of the prior year and ending in December of the prior year (averages for the fourth quarter are not available early enough to be used), and
- The DOE CNG quarterly averages commencing January of the previous year through December of the prior previous year.

2. Adjustment Due to Change in Energy Information Administration (EIA) LNG

The EIA LNG Fuel Component of the Service Fees will be adjusted by the percent change, if any, between the following:

- The EIA LNG monthly average during the 12-month period commencing March 1 of the previous year to the end of February of the current year, and
- The EIA LNG monthly average during the 12-month period commencing March 1 of the prior previous year to the end of February of the previous year.

3. Adjustment Due to Change in DOE Diesel

Beginning on July 1 in the second Calendar Year after commencement of Collection and thereafter on each succeeding July 1, the Diesel Fuel Component will be adjusted by the percent change, if any, between the following:

- The DOE Diesel during the 12-month period commencing April 1 of the previous year to March 31 of the current year, and
- The DOE Diesel during the 12-month period commencing April 1 of the next previous year to March 31 of the previous year.

For example, a contract that started April 1, 2018, will not be eligible for a rate adjustment for CNG on July 1, 2018. On July 1, 2019, the rate adjustment would compare:

- January 2018 through December 2018, and
- January 2017 through December 2017.

The rate adjustment for LNG would also not be eligible on July 1, 2018. On July 1, 2019, the rate adjustment would compare:

- March 1, 2018 through February 28, 2019, and
- March 1, 2017 through February 28, 2018.

E. Service Fee Adjustment for Changes in Refuse Disposal and Green Waste Diversion Facility Fees

The Disposal and Diversion Components of Net Service Fees will be adjusted for any change in Refuse Disposal and Green Waste Diversion tipping fees charged CONTRACTOR by the Solid Waste Facility designated by CONTRACTOR in Contractor Documentation in Exhibit 3D. A minimum of 12 months must elapse between Commencement Date and July 1 of the current year. Changing Director may conditionally approve changing the Solid Waste Facilities to a more expensive facility by not allowing the increased cost to be passed down to the Customer.

1. Facilities Open to Public

The Refuse Disposal and Green Waste Diversion components of the Service Fees will be adjustment by the percent change, if any, between the following:

- The Refuse Disposal and Green Waste Diversion posted tipping fees on January 1 of the current year, and
- The Refuse Disposal and Green Waste Diversion posted tipping fees on January 1 of the previous year.

2. Facilities Not Open to Public

The Refuse Disposal and Green Waste Diversion components of the Service Fees will be adjustment by the percent change, if any, between the following:

- The cost for Refuse Disposal and Green Waste Diversion on January 1 of the current year, and
- The cost for Refuse Disposal and Green Waste Diversion on January 1 of the previous year.

CONTRACTOR must substantiate to the satisfaction of Director changes in tipping fees CONTRACTOR is paying at the Solid Waste Facility by

submitting before March 1, monthly invoices from the Solid Waste Facility, showing the total Tons and rate paid for Disposal/Diversion.

- If CONTRACTOR owns the Solid Waste Facility, it must show the posted gate rate paid by the public that has no financial agreement with CONTRACTOR, by contract or letter-of-agreement, unless there is no posted gate rate.
- If CONTRACTOR owns the Solid Waste Facility but has no posted gate rate, CONTRACTOR must substantiate changes in tipping fees by submitting other documentation acceptable to Director.

If CONTRACTOR does not substantiate to the satisfaction of Director that CONTRACTOR is experiencing that change in tipping fees, the Disposal/Diversion Component will not be adjusted.

For example, CONTRACTOR may own the Solid Waste Facility it designated for Disposal and consequently internalize Disposal costs at the Solid Waste Facility. The costs however must be adequately explained.

3. Transfer (Trans) Loading Plus Disposal/Diversion Elsewhere

The Refuse Disposal and Green Waste Diversion components of the Service Fees will be adjusted by the percent change, if any, between the following:

- The cost for Refuse and Green Waste Transferring, transporting, and Disposal/Diversion on January 1 of the current year, and
- The cost for Refuse and Green Waste Transferring, transporting, and Disposal/Diversion on January 1 of the previous year.

CONTRACTOR must substantiate to the satisfaction of Director fees CONTRACTOR is paying by submitting before March 1, invoices from the Solid Waste Facility, showing the total Tons and rate paid for Transfer loading, expenses for transporting to another facility, Disposal/Diversion at another facility, and any other documentation to support expenses. If CONTRACTOR does not substantiate to the satisfaction of Director that CONTRACTOR is experiencing that change in tipping fees, the Disposal/Diversion Component will not be adjusted.

For example, CONTRACTOR may be paying the Solid Waste Facility \$10 per Ton to a Materials Recovery Facility but will have additional expenses to transport the Refuse to another facility, plus the expense for Disposal at the second facility.

F. Future Service Fee Adjustment Components

As of the Commencement Date, certain expenses in item P of Exhibit 31A are zero because CONTRACTOR does not incur them. The weighted adjustments in

subsection B3 above may be changed if CONTRACTOR incurs those expenses after the Commencement Date. For example, as of the Commencement Date CONTRACTOR has no expenses for Food Waste Collection as shown by zero in item P of Exhibit 3A1. If COUNTY converts the Green Waste Container to an Organics Container for both Green Waste and Food Waste, or adds a separate Food Waste Container, those negotiated expenses discussed would no longer be zero.

G. No Longer Used

H. Temporarily Discontinued Indices

If a price or index is temporarily discontinued on the date of adjustment, the last available price or index for the required period (such as Calendar Year or another 12-month period) will be used.

ATTACHMENT 7-1 – Service Fees Adjustment Example

A. Annual increase or decrease in CPI Example (C of Exhibit 7)

Table 1–Adjustment Due to Change in CPI

Calculate percent change in CPI (12-month average, not month-to-month)	03/01/15-02/29/16	221.64
	03/01/16-02/28/17	228.59
	Percent change	3.14% (not more than COUNTY salary increase)

B. Annual increase or decrease in Fuel Example (D of Exhibit 7)

Table 2A–Adjustment Due to Change in DOE CNG

Calculate percent change in DOE CNG (average of quarters in year – which may vary, not quarter-to-quarter)	January, April, July, and October 2015	$(2.26+1.99+2.02+2.21)/4 = 8.48/4 = 2.12$
	January, April, July, and October 2016	$(2.29+2.33+2.44+2.35)/4 = 9.41/4 = 2.35$
	Percent Change	$(2.35-2.12)/2.12 = 0.23/2.12 = 0.1085=10.85\%$
Adjustment to CNG Fuel Component (% Fleet)	40% of fleet uses DOE CNG (Fleet=4 CNG Vehicles, 6 LNG Vehicles)	$0.40 \times 10.85\% = 4.34\%$

Table 2B - Adjustment Due to Change in EIA LNG

Calculate percent change in EIA LNG (12-month average, not month-to-month)	03/01/15-02/29/16	121.63
	03/01/16-02/28/17	153.01
	Percent Change	2.58%
Adjustment to LNG Fuel Component (% Fleet)	60% of fleet uses EIA LNG (Fleet=4 CNG Vehicles, 6 LNG Vehicles)	$0.60 \times 10.85\% = 6.51\%$

C. Changes in Disposal/Diversion Tipping Fees Example (E of Exhibit 7)

Table 3A–Adjustment Due to Change in Refuse Disposal Tipping Fees at Facility One

Calculate percentage change in Disposal tipping fees	01/01/14 (CONTRACT started 9/1/14)	\$50.00
	01/01/15	\$52.00
	01/01/16	\$55.00
	Percent change (compare to 2014 since no adjustment allowed prior year)	10.00%
Adjustment to Disposal	45% of Disposal at this facility	$0.45 \times 10.00\% = 4.50\%$

Table 3B–Adjustment Due to Change in Refuse Disposal Tipping Fees at Facility Two

Calculate percentage change in Disposal tipping fees	01/01/14 (CONTRACT started 9/1/14)	\$40.00
	01/01/15	\$43.00
	01/01/16	\$46.00
	Percent change (compare to 2014 since no adjustment allowed prior year)	15.00%
Adjustment to Disposal	55% of Disposal at this facility	$0.55 \times 15.00\% = 8.25\%$

Table 3C–Adjustment Due to Change in Green Waste Diversion Tipping Fees at Facility

Calculate percentage change in Diversion tipping fees	01/01/14 (CONTRACT started 9/1/14)	\$30.00
	01/01/15	\$30.00
	01/01/16	\$36.00
	Percent change (compare to 2014 since no adjustment allowed prior year)	20.00%

D. Weighted Service Fee Adjustment Percentage Example (C, D, and E of Exhibit 7)

Table 4–Sum of Adjustments

Component	Relative weight of	Adjustment due to change in indices/ change in disposal tipping fees	Weighted Adjustment Percentage
Service Component (CPI)	65% of Service Fee	3.14%	2.05%
Fuel Component	5% of Service Fee	6.51% + 4.34%	0.54%
Refuse Disposal Component	20% of Service Fee	4.50% + 8.25%	2.55%
Green Waste Diversion Component	10% of Service Fee	20.00%	2.00%
Weighted Service Fee Adjustment Percentage			7.14%

ATTACHMENT 7-2.1 -- Task 1 Service Fees
Lennox

Bidder must provide a rate for each item below. Failure to do so may result in the proposal/bid being rejected as nonresponsive. Note: 96-gallons = 0.5 cu yd.

Services	Monthly Rate Per Customer (Billed to Customer)	Monthly Rate Per Customer (Billed to COUNTY)
MONTHLY RATE		
Monthly Rate for Basic Services, per Refuse Unit (Exhibit 3A1 D1)		(per Refuse Unit)
<ul style="list-style-type: none"> One 96-gallon Refuse One 96-gallon Recyclables One 96-gallon Green Waste One Extra 96-gallon Recyclables One Extra 96-gallon Green Waste 	<ul style="list-style-type: none"> n/a n/a n/a n/a n/a 	<ul style="list-style-type: none"> 15.31 **\$ 2.84 ***\$ 6.43 \$0 \$0
Total of Refuse, Recyclables, and Green Waste		*\$ 24.58 (Basic Service Total)
SURCHARGES ADDED TO MONTHLY RATE		
Extra Carts (Exhibit 3A1 D2)		
<ul style="list-style-type: none"> Each 96-gallon Refuse Cart Each 96-gallon Recyclables Cart Each 96-gallon Green Waste Cart 	<ul style="list-style-type: none"> n/a 96-gal Recycle fee** 96-gal Green Waste fee*** 	<ul style="list-style-type: none"> n/a n/a n/a
Extra or Larger Dumpsters (Exhibit 3A1 D2)		
<ul style="list-style-type: none"> Per 0.5 cu yds of Refuse Per 0.5 cu yds of Recyclables Per 0.5 cu yds of Green Waste 	<ul style="list-style-type: none"> n/a 96-gal Recycle fee** 96-gal Green Waste fee*** 	<ul style="list-style-type: none"> n/a n/a n/a
Increased Frequency of Refuse Dumpster Collection, more than 1x per week (Exhibit 3A1 B3)		
<ul style="list-style-type: none"> 2 times per week 3 times per week 4 times per week 5 times per week 6 times per week (Saturdays) Each extra time per week with no capacity increase (i.e. 3 cubic yards twice per week instead of 6 cubic yards once per week) 	<ul style="list-style-type: none"> 1.0 2.0 3.0 4.0 5.0 0.7 	<ul style="list-style-type: none"> n/a n/a n/a n/a n/a n/a
Additional On-Call Pickups beyond 4 per year (Exhibit 3A1 H3 & Section 7A2e)		
Bulky Items, excess waste, or Green Waste (per visit to collect all items)	One time charge equal to +75% of Basic Service Total*	n/a
Container Size Exchange, beyond 1 per year (Exhibit 3A1 D3)		
<ul style="list-style-type: none"> Each additional exchange 	One time charge equal to +50% of Basic Service Total*	n/a

PW-24.1.1

Services	Monthly Rate Per Customer (Billed to Customer)	Monthly Rate Per Customer (Billed to COUNTY)
Roll-Out Service for non-Elderly/Disabled (Exhibit 3A1 I & Section 7A2d)		
<ul style="list-style-type: none"> Mandatory Minimum Service (Up to 10 feet) Full Service (Up to 50 feet) Extended Full Service <ul style="list-style-type: none"> First 50 feet Each 200 feet Unpaved Steep 	+5% of Basic Services Total* +25% of Basic Services Total* +25% of Basic Services Total* +25% of Basic Services Total* +10% of Basic Services Total* +10% of Basic Services Total*	n/a n/a n/a n/a n/a n/a
Difficult to Service (Exhibit 3A1 O & Section 7A2c)	If applicable to Service Area	
<ul style="list-style-type: none"> Cost per Customer 	+50% of Basic Services Total*	n/a
Manure Service, per collection each week (Exhibit 3A1 D13 & Section 7A2g)	If applicable to Service Area	
<ul style="list-style-type: none"> 64-gallon Cart 2-cubic yard Dumpster Roll-Out/Scout Service 	\$ 85.00 \$ 175.00 Negotiated with Customer	n/a n/a n/a
Bear Resistant Cart-fee per Cart (Exhibit 3A1 D12 & Section 7A2h)	If applicable to Service Area	
<ul style="list-style-type: none"> 96-gallon Cart (Rental with free replacement for Term) 96-gallon Cart (Purchase without free replacement) 	\$ 25.00 \$ 330.00 (one-time)	n/a n/a
Locking Recyclables Cart (Exhibit 3A1 D14)		
<ul style="list-style-type: none"> 96-gallon Cart 	\$ 25.00 (one-time)	n/a
Billing Fees (Section 7B7)		
<ul style="list-style-type: none"> Late fee Interruption of service Returned checks 	10% of past due amount \$25 \$25	n/a n/a n/a

Examples showing amount to be billed to Customer for extra services, assuming Monthly Rate per Refuse Unit to COUNTY is \$20 (made up of \$10 Refuse, \$4 Recycle, \$6 Green):

- If a single-family home wanted a second Refuse Cart, the extra fee would be \$10 (1st Cart paid on taxes, 2nd Cart \$10)
- If a single-family home wanted 3 Recyclables Carts, the extra fee would be \$4. (1st Cart paid on taxes, 2nd Cart at no charge, 3rd Cart \$4)
- If a restaurant wanted one 3-yard Dumpster for Refuse serviced Monday through Saturday, 6 times per week, the extra fee would be \$300 (1st Dumpster paid on taxes at \$10 x 6 Refuse Units for 1x per week = \$60 on taxes, 6 times per week = \$360 - \$60 taxes = \$300).
- If a store that has 2 Refuse Units (1 cu yd) 1x per week assigned and wanted 3 cubic yards of Refuse Collected 2x per week, the extra fee would be \$100 (1 cubic yard paid on taxes at \$10 x 2 Refuse Units, for 1x per week = \$20, 3 cu yds 2x = \$120 - \$20 taxes = \$100)

Bidders are responsible for independently investigating service conditions in the Service Area prior to submission.

WARE DISPOSAL INC

Bidder's Printed Name

Bidder's Signature

9 MAY 2018

Date Signed

ATTACHMENT 7-3.1 – Task 2 Service Fees
Lennox

PW-25.1

Bidder must provide a Service Fee for each item below. Failure to do so may result in the proposal/bid being rejected as nonresponsive. Waste separated by more than ten feet shall be considered a separate incident. Director will calculate the Annual Total based on the proposed Service Fee and the quantity.

Annual Services	Service Fee	Quantities	Annual Total
Abandoned Waste Weekly Collection (Exhibit 3A2 A and Section 7 C3a)			
Expected Number of Incidents, per year, up to 2,400 of up to 4 cu yds: • Alleys (0.26 miles) • Parkways, Sidewalks, Streets (20.98 miles)	\$ 50.00 (per incident)	2017 1bd tons 21.22 miles	
More Than Expected Number of Incidents, per year, between 2,401 and 4,800 of up to 4 cu yds: • Alleys, Parkways, Sidewalks, Streets	\$ 50.00 (per incident)	2016 703.15 tons 21.22 miles	
More than 4 cu yds, up to 360 incidents per year • Alleys, Parkways, Sidewalks, Streets	\$ 125.00 (per incident)		
Abandoned Waste Daily Collection (Exhibit 3A2 A5 and Section 7 C3b)			
Monitoring All Hot Zone Locations	\$ 0.25 /foot (per day)	4 locations 260 days	
Waste Collection from All Hot Zone Locations, of piles up to 4 cu yds	\$ 125.00 (per day)	2,550 feet 100 tons (est.)	
Additional Hot Zones Monitoring	\$ 0.25 /foot (per day)	260 days 638 feet	
Additional Hot Zones Waste Collection, of piles up to 4 cu yds per day	\$ 125.00 (per day)	25 tons (est.)	
Waste Collection from Hot Zones, of piles with more than 4 cu yds	\$ 125.00 (per incident)	130 incidents	
Public Receptacles (Exhibit 3A2 B and Section 7 C3c)			
Standard or Solar Compactors (assume Collection twice per day, 6 days per week)	\$ 28.00/receptacle (per Collection)	15 receptacles	
Additional public receptacles (up to 125% more receptacles)	Rate same as above	19 receptacles	
Homeless Encampments (Exhibit 3A2 E and Section 7 C3d)			
Abandoned Encampments • Waste Collection for each 4 cu yds	\$ 125.00	25 loads of 4 cu yds	
Occupied Encampments (weekly service) • Bags • Boxes (Refuse in bags from event box) • Dumpsters • Sharps	\$ 15.00/bag \$ 25.00/bag-box \$ 150.00/Dumpster \$ 75.00/container	(per week) 50 bags 50 bags 10 Dumpsters 25 containers	
Maximum COUNTY Services Sum:			\$

Bidders are responsible for independently investigating service conditions in the Service Area prior to submission

WAHE DISPOSAL INC
Bidder's Printed Name

[Signature]
Bidder's Signature

9 MAY 2018
Date Signed

Attachment 7-5

Enclosure
FORM PW-2.1.1

**SCHEDULE OF PRICES
FOR
LENNOX GARBAGE DISPOSAL DISTRICT (2018-GDD017)**

The undersigned Bidder offers to perform the work described in the Invitation for Bids (IFB) for the following prices. The Bidder's rate(s) (hourly, monthly, etc.) shall include all administrative costs, labor, supervision, materials, transportation, taxes, equipment, and supplies unless those specified to be furnished by Public Works. It is understood and agreed that where quantities, if any, are set forth in the Schedule of Prices, they are only estimates, and the unit prices quoted, if any, will apply to the actual quantities, whatever they may be.

The term of this contract is approximately **seven years**, starting as early as **July 1, 2018**, and ending **June 30, 2025**, plus two 18-month extension options and six 1-month extension options, not to exceed a total contract period of ten years and six months.

TASK 1

Using the examples given below calculate your Monthly Unit Rate, Monthly Payment Rate, Hourly Rate, and Total Proposed Annual Amount. The Unit Count given is the current unit count for the Garbage Disposal District but may be revised as outlined in Item 16 C5 1 of Exhibit 16, Unit Counts and Payment Rates.

The automated collection, transportation, and disposal of refuse and separate automated collection and management of recyclable materials and green waste from the District's residences, multi-family residences, businesses, and commercial/industrial establishments, as specified.

	Unit Count		Monthly Unit Rate	=	Monthly Payment Rate	Months	=	Proposed Annual Amount
Example	3,059	x	\$ 7.4724	=	\$ 22,858.07	x 12	=	\$ 274,296.84
Actual	5,508	x	\$ 24.58	=	\$ 135,386.64	x 12	=	\$ 1,624,639.68
Example	Two hundred seventy-four thousand two hundred ninety-six dollars and eighty-four cents.							
	WRITTEN TOTAL PROPOSED ANNUAL AMOUNT FOR ITEM 1A							
Actual	<u>One million six hundred twenty-four thousand, six hundred thirty-nine dollars and sixty cents</u>							
	WRITTEN TOTAL PROPOSED ANNUAL AMOUNT FOR ITEM 1A							

TASK 2

REMOVAL OF DISCARDED MATERIALS FROM PUBLIC RIGHT-OF-WAY AND PUBLIC CURBSIDE RECEPTACLES COLLECTION SERVICE. Calculate your Monthly Rate, Monthly Payment Rate, and Total Proposed Annual Amount.

2A. ABANDONED WASTE WEEKLY COLLECTION FROM PUBLIC RIGHT-OF-WAY

The clean-up, collection, transportation, disposal, and management of discards, as specified, within the public road right-of-way, in unlimited quantities, from all the alleys within the District.

FORM PW-2.1.1

	Types of Incidents	Number of Incidents		Rate (per incident)	=	Proposed Annual Amount
i	Expected No. of Incidents (up to 4 cu yds)	2,000	x	\$ 50.00	=	\$ 100,000.00
ii	More Than Expected Number of Incidents (up to 4 cu yds)	4,800	x	\$ 50.00	=	\$ 240,000.00
iii	More Than 4 cu yds Incidents	360	x	\$ 125.00	=	\$ 45,000.00
TOTAL PROPOSED ANNUAL AMOUNT FOR TASKS 2A (i + ii + iii)						\$ 385,000.00
Three hundred eighty-five thousand and zero cents						WRITTEN TOTAL PROPOSED ANNUAL AMOUNT FOR TASKS 2A (i + ii + iii)

2B. ABANDONED WASTE DAILY COLLECTION FROM HOT ZONES

The clean-up, collection, transportation, disposal, and management of discards, as specified, within the public road right-of-way, in unlimited quantities, from all from Hot Zones within the District.

2B1	Monitoring	Quantity (feet)		Rate (per foot)		Number	=	Proposed Annual Amount
i	Monitoring All Hot Zone Locations	2,550	x	\$ 0.25	x	260 days	=	\$ 165,750.00
ii	Additional Hot Zone Monitoring	638	x	\$ 0.25	x	260 days	=	\$ 41,470.00
TOTAL PROPOSED ANNUAL MONITORING AMOUNT FOR TASKS 2B (i + ii)								\$ 207,220.00

2B2	Waste Collection			Rate		Number	=	Proposed Annual Amount
iii	Waste Collection from All Hot Zones, up to 4 cu yds (every weekday)			\$ 125.00 (per day)	x	260 days	=	\$ 32,500.00
iv	Additional Hot Zone Waste Collections, up to 4 cu yds (every weekday)			\$ 125.00 (per day)	x	260 days	=	\$ 32,500.00
v	Waste Collection from Hot Zones piles of more than 4 cu yds			\$ 125.00 (per incident)	x	130 incidents	=	\$ 16,250.00
TOTAL PROPOSED ANNUAL COLLECTION AMOUNT FOR TASKS 2B (iii + iv + v)								\$ 81,250.00

	Proposed Annual Amount for Monitoring Task 2B1	+	Proposed Annual Amount for Collection Task 2B2	=	Total Proposed Annual Amount for Tasks 2B1 + 2B2
Example	\$ 100,000.00	+	\$ 105,750.00	=	\$ 205,750.00
Actual	\$ 207,220.00	+	\$ 81,250.00	=	\$ 288,470.00
Example	Two hundred sixty-eight thousand, seven hundred fifty dollars and zero cents				
	WRITTEN TOTAL PROPOSED ANNUAL AMOUNT FOR TASKS 2B1 + 2B2				
Actual	Two hundred eighty-eight thousand, four hundred seventy dollars and zero cents				
	WRITTEN TOTAL PROPOSED ANNUAL AMOUNT FOR TASKS 2B1 + 2B2				

FORM PW-2.1.1

2C. PUBLIC CURBSIDE RECEPTACLES

The clean-up, collection, transportation, disposal, diversion, and management of discards, as specified, in unlimited quantities, from specified public curbside refuse or recyclable receptacles within the District. Unit Cost **the cost of cleanup for one receptacle, one time, regardless of standard or solar compacting.**

	Total number of public curbside receptacles		Monthly Rate (per receptacle per month)	=	Monthly Payment Rate	Months	Proposed Annual Amount
Example	80	x	\$ 290.00	=	\$ 23,200.00	x 12	= \$ 278,400.00
Actual	15	x	\$ 26.00	=	\$ 390.00	x 12	= \$ 4,680.00
Example	<i>Two hundred forty thousand dollars and zero cents</i>						
	WRITTEN TOTAL PROPOSED ANNUAL AMOUNT FOR ITEM 2C						
Actual	<i>Four thousand six hundred eighty dollars and zero cents</i>						
	WRITTEN TOTAL PROPOSED ANNUAL AMOUNT FOR ITEM 2C						

TASK 2 - TOTAL PROPOSED ANNUAL AMOUNT (FOR ITEMS 2A, 2B, 2C)

Proposed Annual Amount for Task 2A	+	Proposed Annual Amount for Task 2B	+	Proposed Annual Amount for Task 2C	=	Total Proposed Annual Amount for Tasks 2A + 2B + 2C
\$ 385,000.00	+	\$ 288,470.00	+	\$ 4,680.00	=	\$ 678,150.00
<i>Six hundred seventy thousand one hundred fifty dollars and zero cents</i>						
WRITTEN TOTAL PROPOSED ANNUAL AMOUNT FOR ITEM 2A + 2B + 2C						

TOTAL PROPOSED ANNUAL AMOUNT FOR TASKS 1 AND 2

Total Proposed Annual Amount for Task 1	+	Total Proposed Annual Amount for Task 2	=	TOTAL PROPOSED ANNUAL AMOUNT FOR TASKS 1 + 2
\$ 1,624,639.68	+	\$ 678,150.00	=	\$ 2,302,789.68
<i>Two million, three hundred two thousand, seven hundred eighty-nine dollars and sixty-eight cents</i>				
WRITTEN TOTAL PROPOSED ANNUAL AMOUNT FOR TASKS 1 AND 2				

By signing below, I declare under penalty of perjury under the law of California that the information stated above is true and correct.

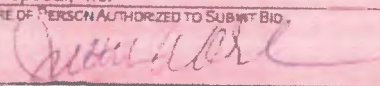
LEGAL NAME OF BIDDER Ware Disposal, Inc.		
SIGNATURE OF PERSON AUTHORIZED TO SUBMIT BID 		
TITLE OF AUTHORIZED PERSON President		
DATE June 27, 2018	STATE CONTRACTOR'S LICENSE NUMBER N/A	LICENSE TYPE N/A
BIDDER'S ADDRESS 1451 Manhattan Ave., Fullerton, CA 92831-5221		
PHONE 877-714-9273	FAX 714-664-0696	E-MAIL lay@waredisposal.com

Attachment 11-1.1 I – Emergency Service Fees
Lennox

PW-26.1

Bidder must provide a rate for each item below. Failure to do so may result in the proposal/bid being rejected as nonresponsive.

Services	Monthly Rate Per Customer (billed to COUNTY)
As-Needed Emergency (Section 11B) <ul style="list-style-type: none"> • Task 1 Services • Solid Waste not in Containers • Roll-Off Containers or Drop-Off Events • Palm Fronds 	Comparable Municipal Solid Waste fees \$ 55.00 /ton and \$ 12.50 /cubic yard Comparable Municipal Solid Waste fees \$ 135.00/hour per Vehicle

Bidders are responsible for independently investigating service conditions in the Service Area.

WARE DISPOSAL INC
Bidder's Printed Name

Bidder's Signature

9 MAY 2018
Date Signed

EXHIBIT 12-D2 – Liquidated Damages

Reference to "failure" refers to each occurrence of specified Breach (such as for each Occupant and each Occupant's Collection site, Record entry, or complaint) and not for aggregate occurrences of those Breaches (such as for all Customers and Occupants on a given route or day). Per day means each business day except as indicated.

If CONTRACTOR does not timely submit the applicable information, documentation or complete Report or incorporate comments, additions and corrections made by Director within five days of receipt of those comments, additions, and corrections, it shall pay the following liquidated damages.

No.	Description of Liquidated Damage	Amount
CUSTOMER SERVICE		
C01	For each failure to honor commitment to resolve a Customer's or Occupant's first complaint in accordance with Section 6D1.	\$100
C02	For each failure to honor commitment to resolve Customer's or Occupant's same complaint, which generated a second complaint, in accordance with Section 6D1.	\$250
C03	For each failure to honor commitment to resolve Customer's or Occupant's same complaint, which generated a third or more complaint, in accordance with Section 6D1.	\$500 for each subsequent complaint
C04	For each failure to enter Customer or Occupant call or e-mail into log or maintain and supply Records of complaints in accordance with Section 6D2.	\$100
C05	For each occurrence of charging any Customer more than the Customer owes for Task 1 Services (such as for the wrong level of service) or charging any Customer more than Customer Service Fees, in Breach of Section 5.	\$100 to COUNTY per Customer plus returning 110% of overcharged amount payable to Customer
C06	If CONTRACTOR violates the nondiscrimination provisions of this CONTRACT, including Exhibit 5.	\$500
CONTRACT LANGUAGE		
L01	Failure to maintain an emergency number or make staff available thereat in accordance with item J1 of Section 4.	\$75 per day
L02	Failure to provide documentation for review or comment by Director or obtain any approval, consent or other permission of Director required under this CONTRACT, including: <ul style="list-style-type: none"> • Customer and Occupant correspondence under item F of Section 4 • Publicity materials under item G1 of Section 4; • News releases and trade journal articles related to Solid Waste Collection services, under item G2 of Section 4 • Customer and Occupant outreach materials under item L of Exhibit 3A1. 	\$1,000 per occurrence and \$1,000 each calendar day before retraction or correction of misinformation identified by Director
L03	Failure to timely submit documentation for review or comment by Director. This includes Section 3D and Exhibit 3D Contractor Documentation.	\$300 per occurrence plus \$100 per day late
L04	Each failure during any calendar month to return Director calls or to timely meet with COUNTY in accordance with Section 4H.	\$500
L05	Each failure to timely submit satisfactory proof of notification (mailing) in accordance with item L4b(4) of Exhibit 3A1.	\$200

No.	Description of Liquidated Damage	Amount
L06	Marketing or distributing mailing lists with the names and addresses of Customers and Occupants, in accordance with item F of Section 1.	\$10 per Customer and Occupant per occurrence
L07	Failure to maintain telephone service in accordance with Section 6B.	\$75 per day
L08	Failure to maintain electronic/paperless service in accordance with Section 6C.	\$75 per day
L09	Failure to allow Director to inspect, audit, review Records, or copy Records in accordance with Section 9C.	\$500
L10	Failure to timely submit AB 939 Records or other required Records in accordance with item E of Section 9.	\$100 per week late
REPORTING TO COUNTY		
R01	Failure to submit Monthly Reports in accordance with items A1 and B1 of Section 10.	\$100 per day
R02	Failure to submit Quarterly Reports in accordance with items 10A2 and 10B2 of Exhibit 3D.	\$200 per day
R03	Failure to submit Annual reports in accordance with items 10A3 and 10B2 of Exhibit 3D	\$300 per day
R04	Failure to report adverse information in accordance with items C of Section 10.	\$300 per occurrence
R05	Failure to deliver Route maps and schedules in accordance with item B16 of Exhibit 3D.	\$100 per day
R06	Failure to submit GPS Reports or video in accordance with item E9 of Exhibit 3A1	\$100 per day per vehicle
SERVICES TO CUSTOMERS, OCCUPANTS, AND COUNTY		
S01	For each failure to Collect Solid Waste in accordance with Section 6D3 and item B of Exhibit 3A1.	\$500 per day plus \$10 for each missed Occupant per day
S02	Failure to immediately clean up litter, spills or liquid leaks in accordance with Section 4A1, 4A2 or 4A3, respectively.	\$150 per parcel per calendar day
S03	For each failure to prevent spills or liquid leaks in accordance with Section 4A2 and 4A3.	\$500
S04	For each failure to equip a Collection Vehicle with signs in accordance with item E7 of Exhibit 3A1.	\$100 per week
S05	For each occurrence of excessive noise in accordance with item A4 of Section 4.	\$300
S06	Commingling materials from outside the Service Area with Solid Waste that CONTRACTOR Collects inside the Service Area, in accordance with item I of Section 4.	\$500 per Vehicle-Occurrence
S07	For each failure to follow its Unpermitted Waste Screening Protocol in accordance with item A of Section 13.	\$500
S08	Failure to repair damage caused to private property in accordance with Part 9C of Exhibit 5.	\$150
S09	Failure of any Vehicle to deliver Solid Waste to the Solid Waste Facilities designated by CONTRACTOR in accordance with item F of Exhibit 3A1.	\$500 per Vehicle
S10	For each occurrence Collecting any Solid Waste during unauthorized hours prohibited under item B2 of Exhibit 3A1, without Director approval.	\$500 plus \$10 for each Container or Bulky Item Collected
S11	For each failure to timely provide, maintain, or repair Container in accordance with item D of Exhibit 3A1.	\$25 per day
S12	For each occurrence of failing to return emptied Container upright, or to their Set-Out Sites, or placing Container in a location that impedes pedestrian or vehicular traffic in accordance with item D5 of Exhibit 3A1.	\$250

No.	Description of Liquidated Damage	Amount
S13	For each use of an unapproved Container design including labeling, in accordance with Section 13D and item D of Exhibit 3A1.	\$50
S14	For each occurrence of disposing of Recyclables, or mixing Recyclables or Green Waste with Refuse in accordance with item G2 of Exhibit 3A1.	\$200 per Vehicle
S15	For each failure to maintain any Vehicle in accordance with Applicable Law	\$150 per Vehicle per day
S16	For each failure to tag uncollected Solid Waste and keep a record of reason, in accordance with Section 4C	\$150
S17	For each failure to Collect Abandoned Waste within 2 Service Days of Director request, in accordance with item A of Exhibit 3A2.	\$100 per day
S18	For failure to maintain an alley segment (1 block) or a Hot Zone (1 area) on the scheduled day, in accordance with items A2 and A4 of Exhibit 3A2.	\$250 per day
S19	For each failure to Collect Solid Waste from public receptacles on the scheduled day and time or failure to maintain (clean), in accordance with item B of Exhibit 3A2.	\$50 per receptacle per missed Collection
S20	Failure to maintain and operate GPS and Video Equipment in working order, in accordance with item E9 of Exhibit 3A1.	\$100 per Vehicle per day

By placing initials below at the places provided, each Party specifically confirms the accuracy of the statements made above and the fact that each Party has had many opportunities to consult with legal counsel and obtain an explanation of liquidated damage provisions of the time that this CONTRACT was made.

CONTRACTOR
Initial Here: 

COUNTY
Initial Here: 

Intentionally left blank

EXHIBIT 16 – Contract Service Area Information

- A. **Maps**
- B. **Sample Graphics**
- C. **Lists**
- D. **Outreach**

Replace page with actual maps, graphics, and outreach samples

P:\epub\ResGDD\General\Contract Renewals\08 Contract Template 14f - Exhibits.docx

Item 16.A.1.1 Service Area and Collection Schedule

Lennox Garbage Disposal District

Service Area

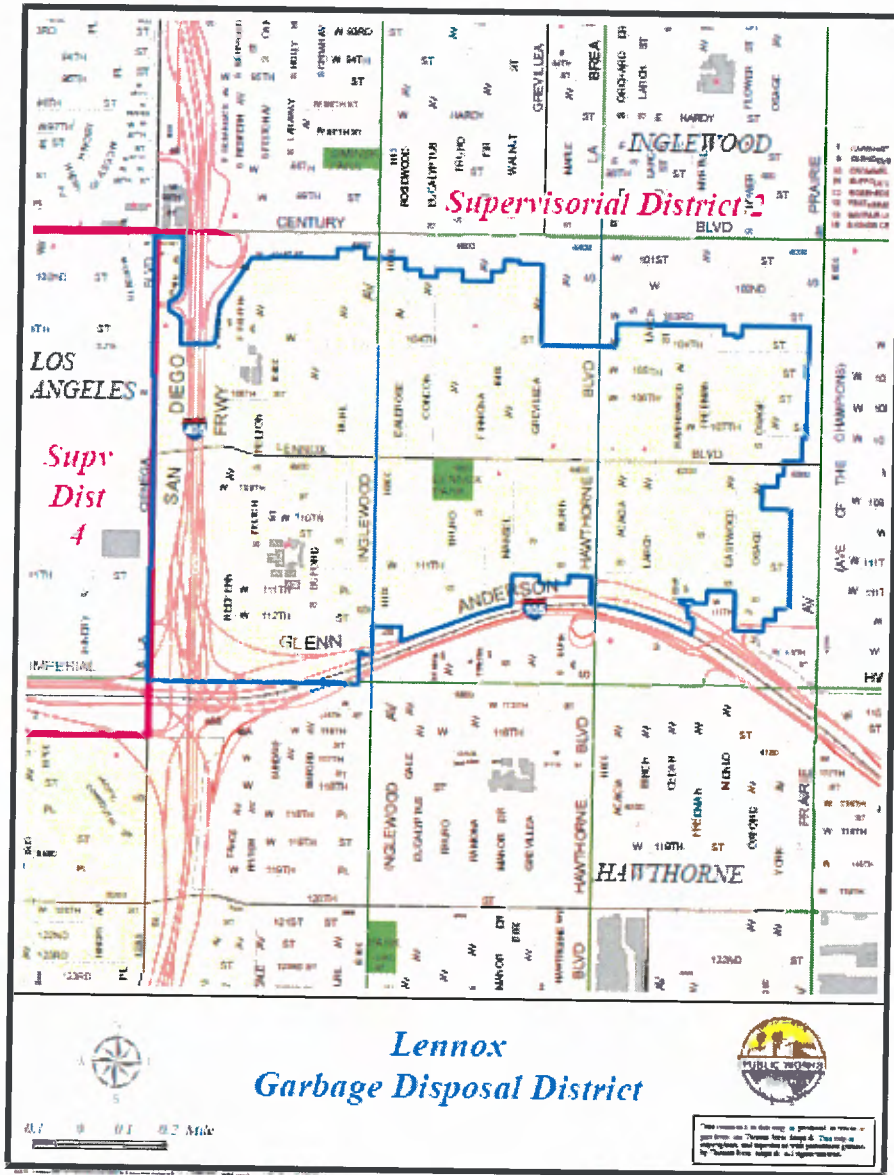

Collection Map

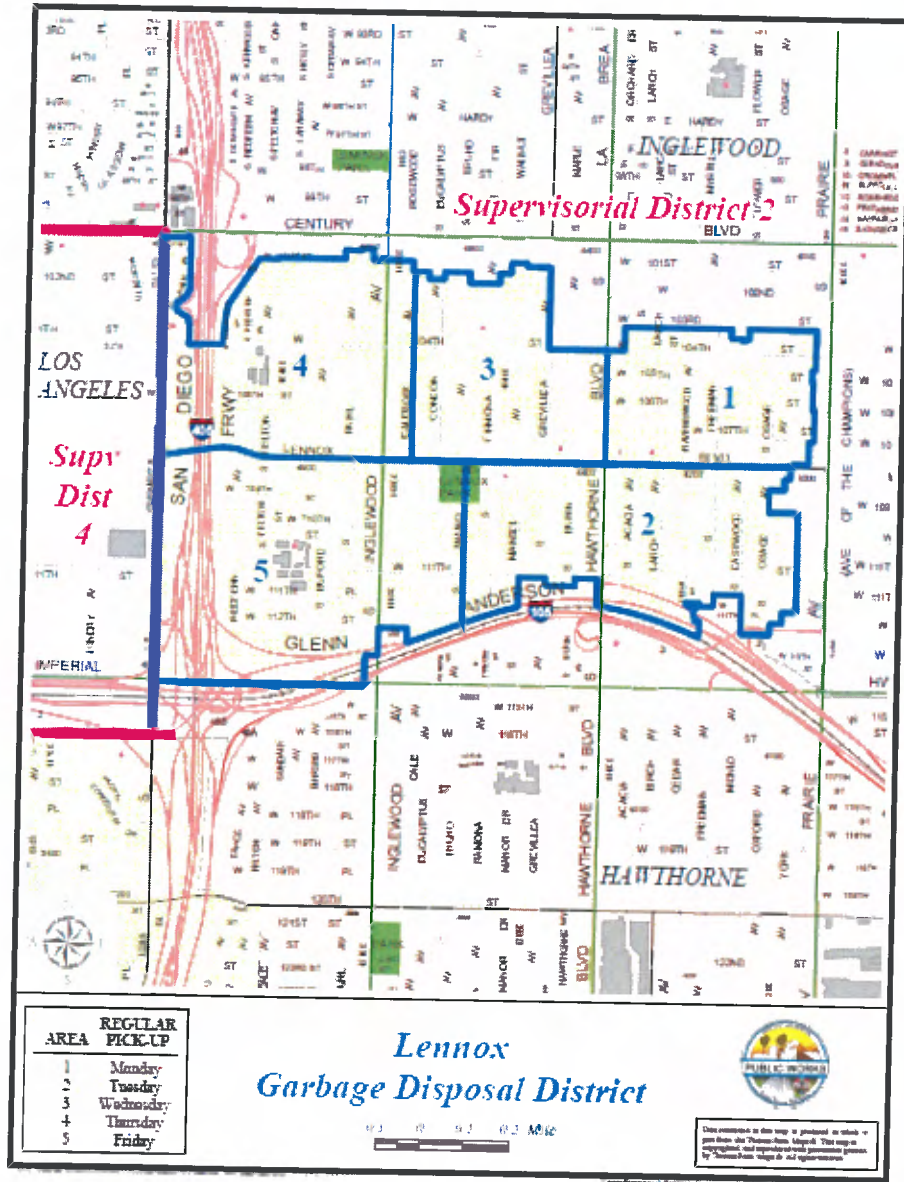

Collection Schedule – Tuesday Service Area

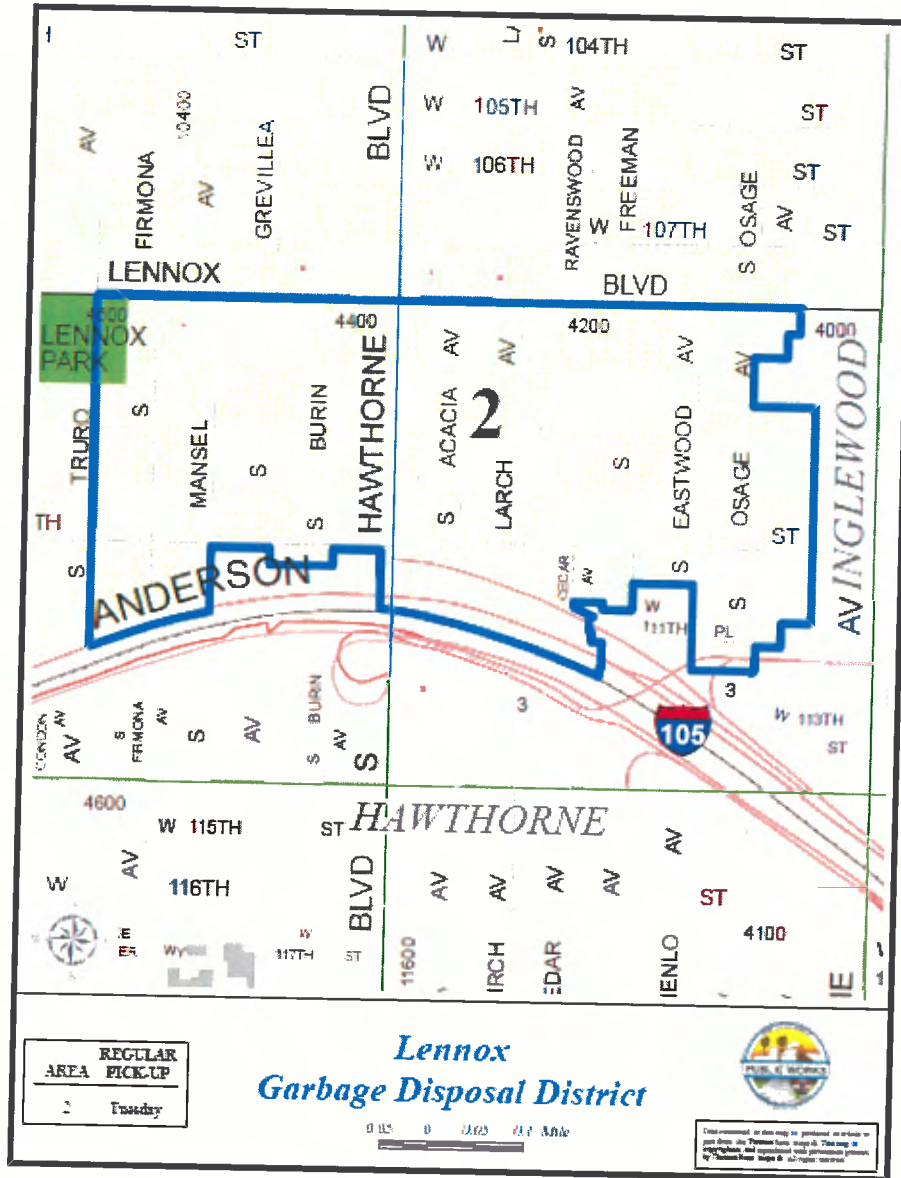

Collection Schedule – Wednesday Service Area



Collection Schedule – Thursday Service Area

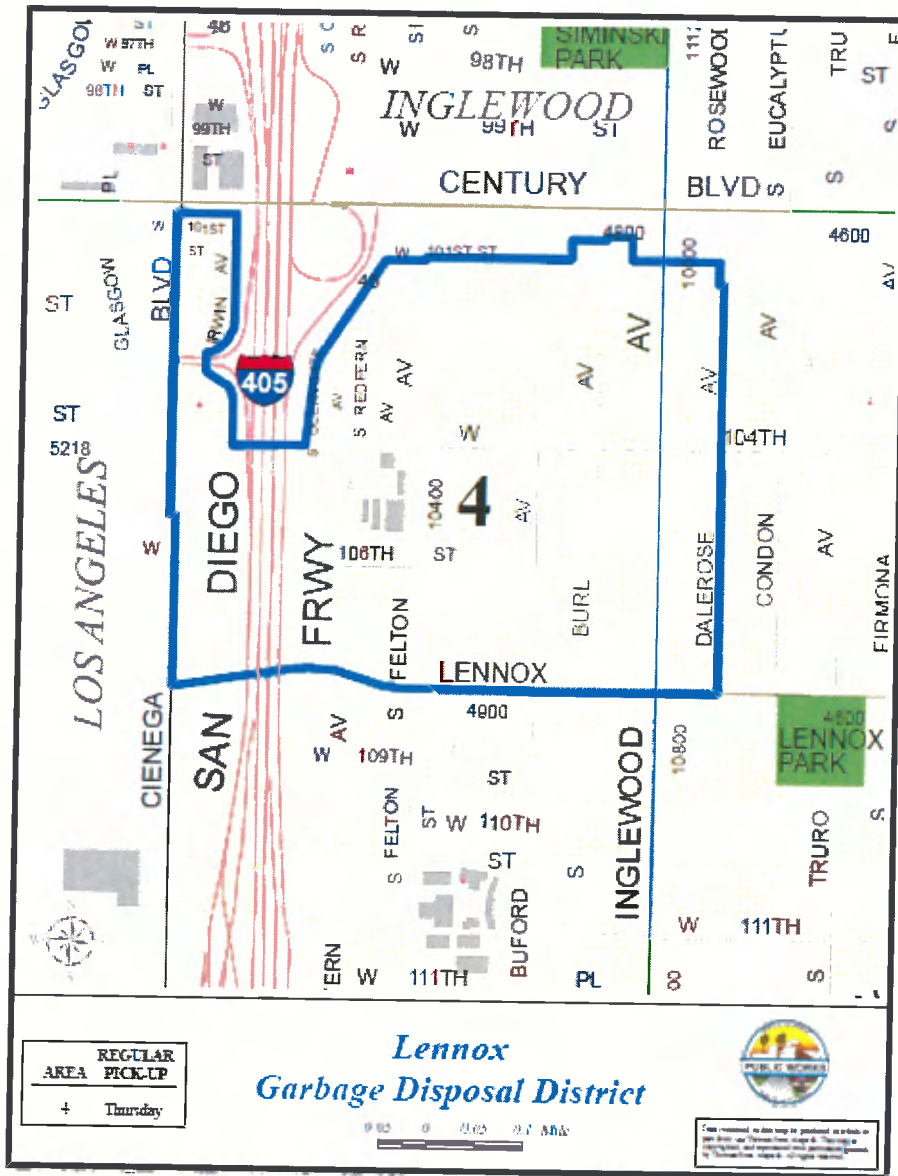

REGULAR AREA	PICK-UP
+	Thursday

Lennox
Garbage Disposal District



This material is for use as provided in order to give notice of the time and date of collection. It is not intended to constitute a contract and is subject to change without notice.

Collection Schedule – Friday Service Area

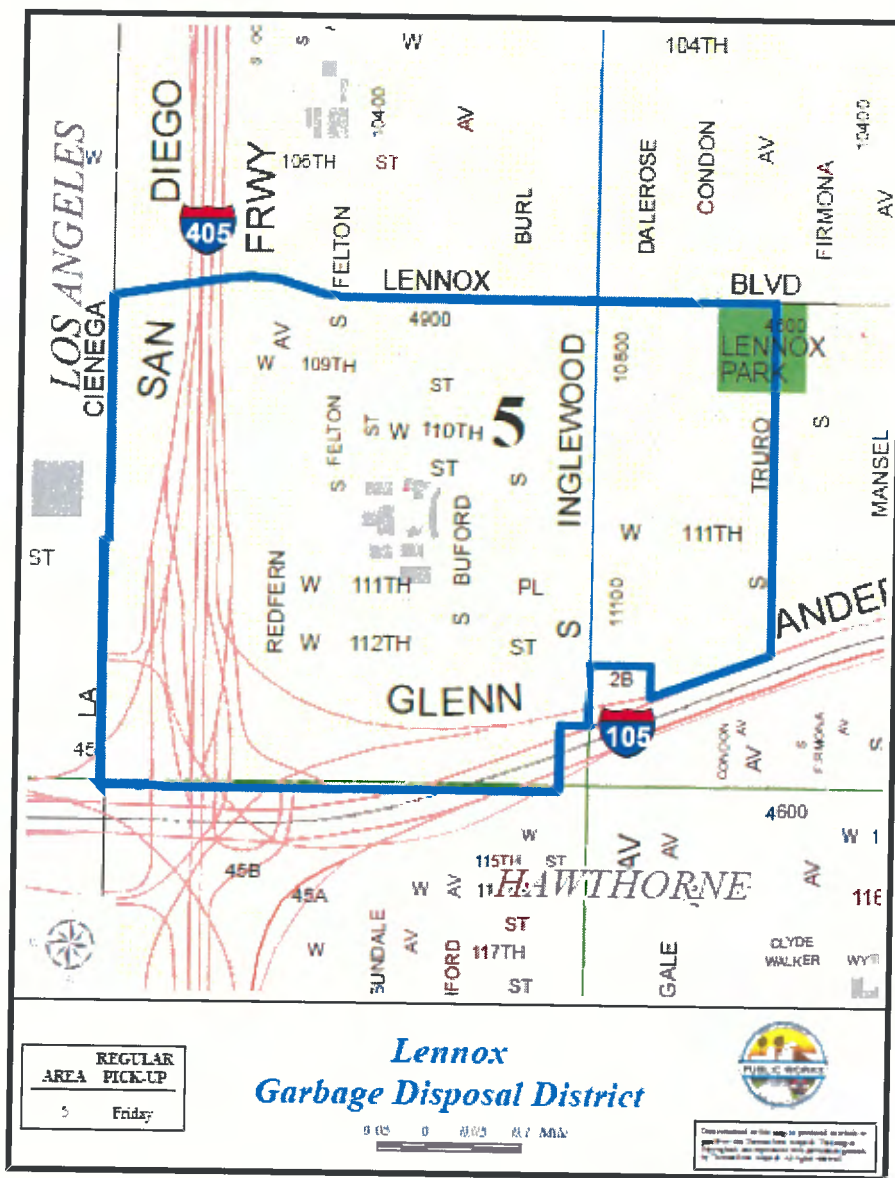

Section 16.A.2.1 Hot Zones

Lennox Garbage Disposal District

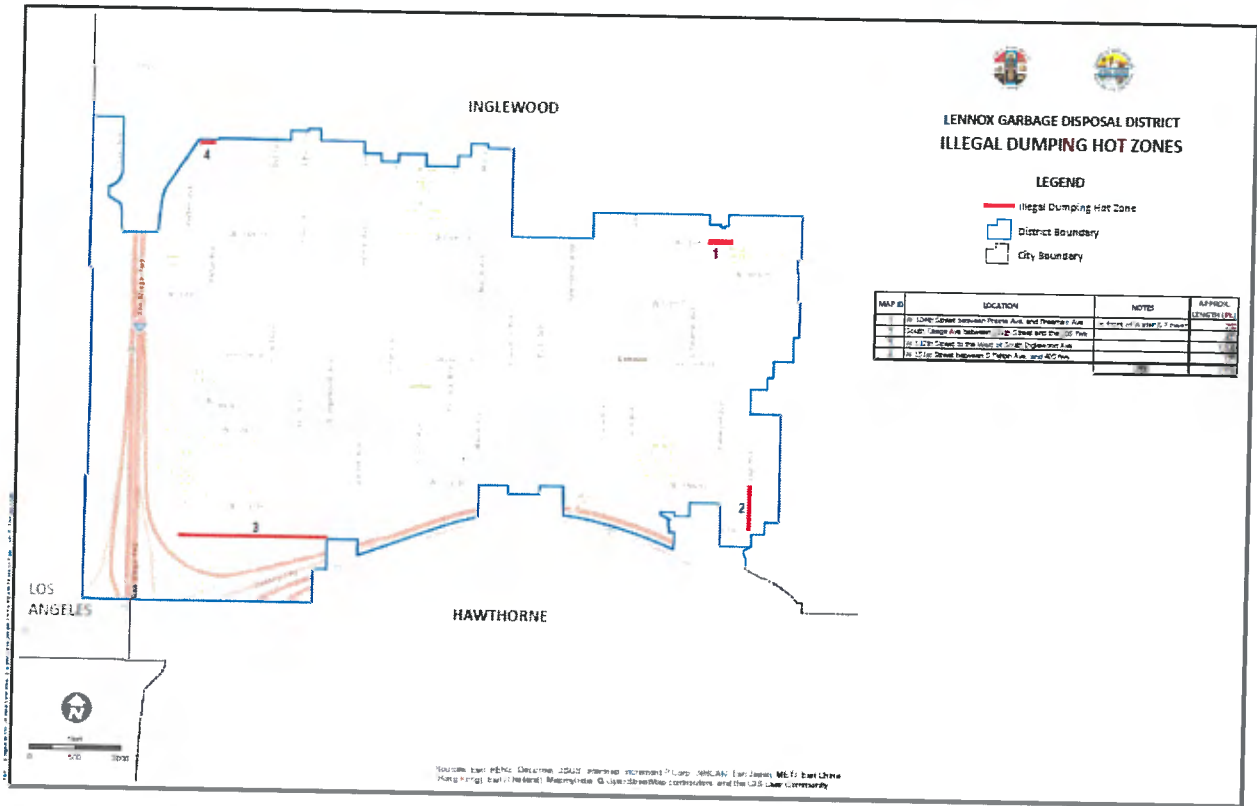

Item 16.A.5.1 Alleys

Lennox Garbage Disposal District

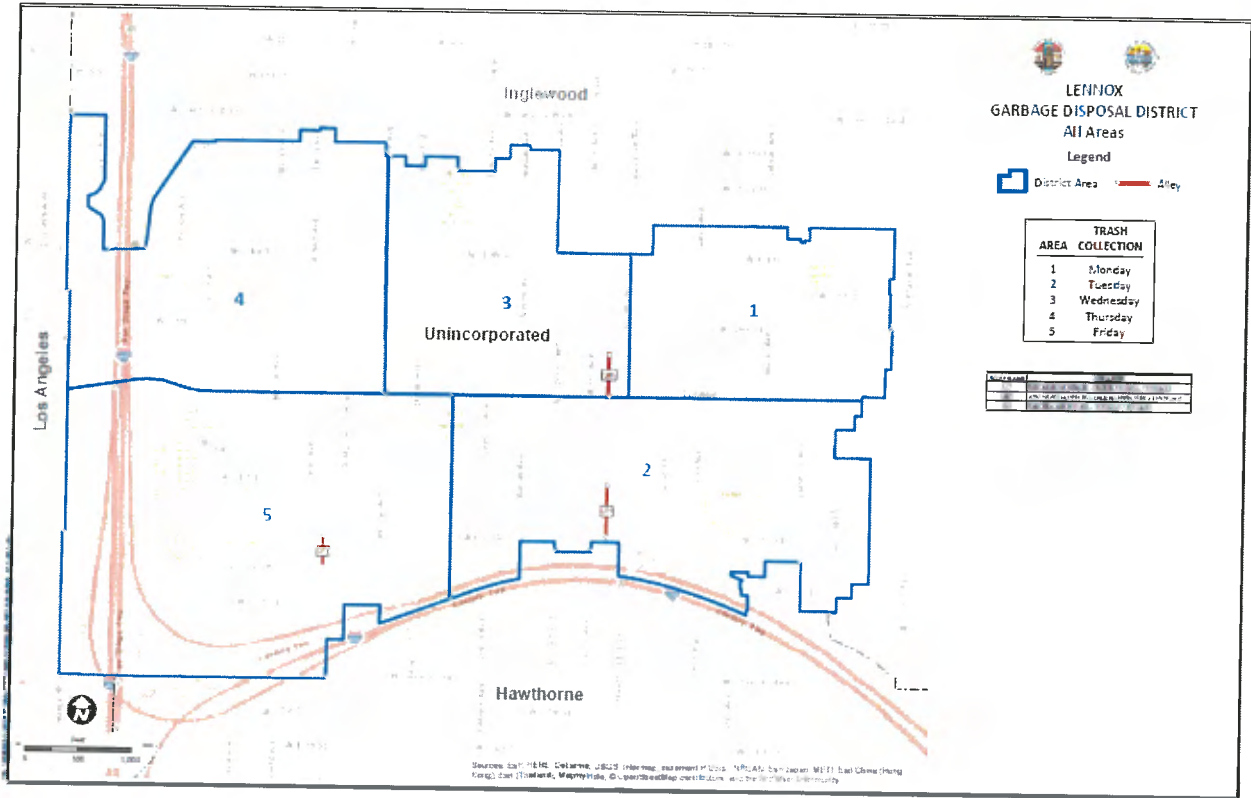

Item 16.A.6.1 Public Receptacles

Lennox Garbage Disposal District

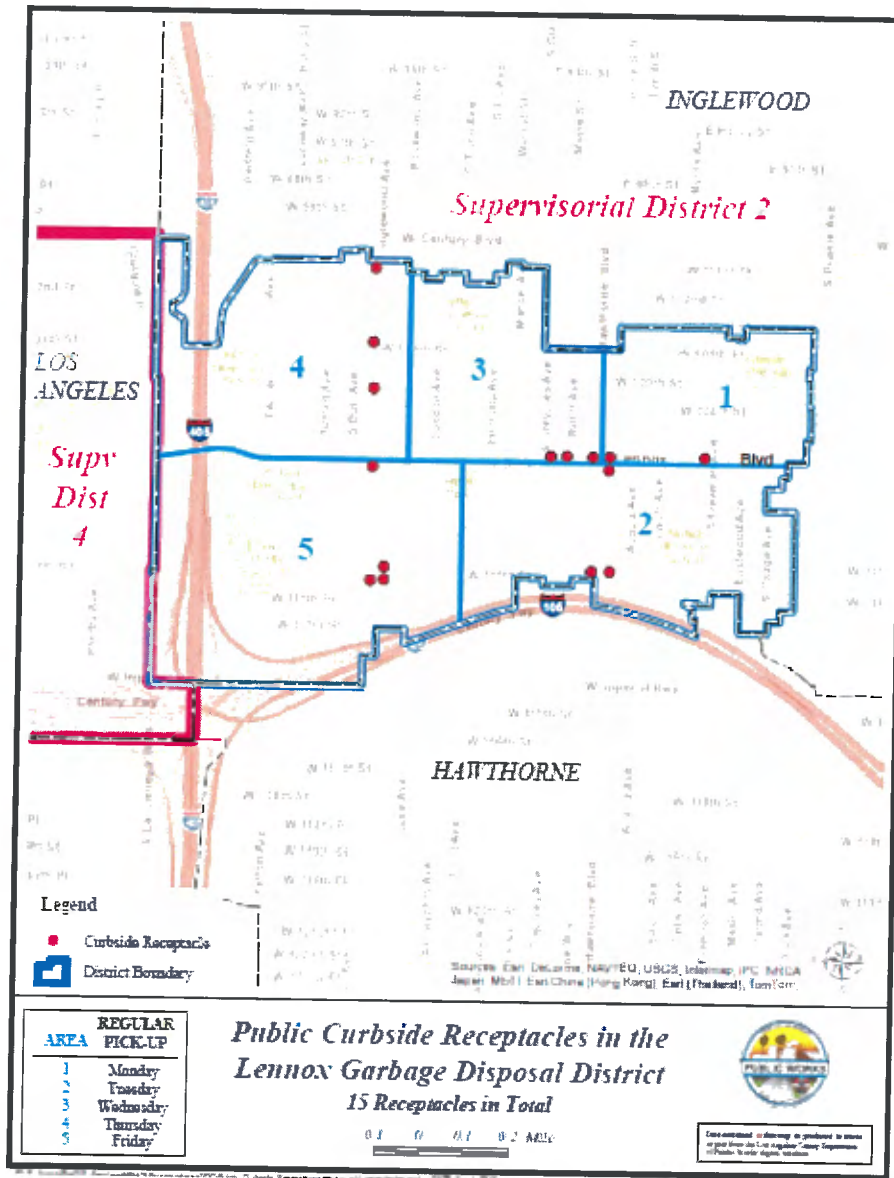

Item 16.B.1 Cart Lid Labels

TRASH ONLY / BASURA SOLAMENTE

ACCEPTABLE

Palm Fronds
Household Waste

NOT ACCEPTABLE

Green Waste
Recyclables
Concrete
Construction Debris
*Hazardous and
Electronic Waste

ACEPTABLES

Hojas de palmeras
Residuos domésticos

NO ACCEPTABLES

Deshechos verdes
Reciclables
Concrete
Residuos de construcción
*Desechos peligrosos y
Electrodomésticos

*Antifreeze, Household Cleaners, Motor Oil, Paint Thinner, Paints; latex or oil-based, Televisions, Monitors, etc.

For more information about disposing these materials contact: 1 (888) CLEAN LA or CleanLA.com

To Request Replacement and/or Additional Cart(s) contact (Waste Hauler Name) 1-888XXX-XXXX

*Anticongelante, Limpiadores del hogar, Aceite de motor, Diluyente de pintura, Pinturas de látex o en base de aceite, televisores, monitores, etc.

Para más información acerca de la eliminación de estos materiales llame al: 1 (888) CLEAN LA o CleanLA.com

Para solicitar reemplazo de, y / o carritos adicionales, comuníquese con (Waste Hauler Name) 1-888XXX-XXXX



RECYCLABLES ONLY / RECICLABLES SOLAMENTE

ACCEPTABLE

Paper
Aluminum
Metal
Cardboard
Plastic Bottles
Glass

NOT ACCEPTABLE

Garbage
Fluids
Batteries
Diapers
Green Waste
Styrofoam
*Hazardous and
Electronic Waste

ACEPTABLES

El localizador
Aluminio
Metal
Cartón
Botellas de plástico
Vidrio

NO ACCEPTABLES

Basura
Líquidos
Baterías
Pañales
Deshechos verdes
Espuma de poliestireno
*Desechos peligrosos y
Electrodomésticos

*Antifreeze, Household Cleaners, Motor Oil, Paint Thinner, Paints; latex or oil-based, Televisions, Monitors, etc.

For more information about disposing these materials contact: 1 (888) CLEAN LA or CleanLA.com

To Request Replacement and/or Additional Cart(s) contact (Waste Hauler Name) 1-888XXX-XXXX

*Anticongelante, Limpiadores del hogar, Aceite de motor, Diluyente de pintura, Pinturas de látex o en base de aceite, televisores, monitores, etc.

Para más información acerca de la eliminación de estos materiales llame al: 1 (888) CLEAN LA o CleanLA.com

Para solicitar reemplazo de, y / o carritos adicionales, comuníquese con (Waste Hauler Name) 1-888XXX-XXXX

GREEN WASTE ONLY / DESECHOS VERDES SOLAMENTE

ACCEPTABLE

Leaves
Grass Clippings
Branches
Brush
Saw Dust
Tree Trimmings

NOT ACCEPTABLE

Construction Debris
Garbage
Palm Tree Trimmings
Palm Fronds
Cactus
Rocks
Plastic or Paper Bags
Animal Waste
*Hazardous and
Electronic Waste

ACEPTABLES

Hojas
Recortes de Césped
Ramas
Arbusto
Aserrín
Recortes de árboles

NO ACCEPTABLES

Residuos de construcción
Basura
Recortes de palmeras
Hojas de palmeras
Nopal
Piedra
Bolsas de plástico o papel
Desechos de mascotas
*Desechos peligrosos y
Electrodomésticos

*Antifreeze, Household Cleaners, Motor Oil, Paint Thinner, Paints; latex or oil-based, Televisions, Monitors, etc.

For more information about disposing these materials contact: 1 (888) CLEAN LA or CleanLA.com

To Request Replacement and/or Additional Cart(s) contact (Waste Hauler Name) 1-888 XXX-XXXX.

*Anticongelante, Limpiadores del hogar, Aceite de motor, Diluyente de pintura, Pinturas de látex o en base de aceite, televisores, monitores, etc.

Para más información acerca de la eliminación de estos materiales llame al: 1 (888) CLEAN LA o CleanLA.com

Para solicitar reemplazo de, y / o carritos adicionales, comuníquese con (Waste Hauler Name) 1-888 XXX-XXXX

WARNING

NO SCAVENGING

DO NOT REMOVE MATERIALS

PUNISHABLE BY FINE UP TO \$5,000

Los Angeles County Code § 20.72.196
California Public Resources Code § 41953

ADVERTENCIA

NO SE PERMITE

REMOVER MATERIALES

RECICLABLES

SE APLICARAN MULTAS HASTA \$5,000

Código del Condado de Los Angeles § 20.72.196
Código de los Recursos Públicos de California § 41953

Item 16.B.2 – Dumpster Labels

Please place these items in the recycling bin
Por favor coloque estos artículos en el contenedor de reciclaje







Office Paper <i>Papel De Oficina</i>	Aluminum, Tin, Metal, Bi-metal <i>Aluminio, Lata, Bi-metálico</i>	Glass <i>Vidrio</i>	Plastics <i>Plásticos</i>	Clean, Small, Pieces of Wood <i>Pedazos Pequeños De Madera</i>
				
Newspapers, Magazines, Junk Mail <i>Periodicos, Revistas y Correo No Deseado</i>	NO:		Cardboard and Dry Food Boxes <i>Cajas De Cartón y de Alimentos</i>	
	<div style="background-color: red; color: white; padding: 5px;"> <p>Food Waste <i>Desperdicios De Comida</i></p> <p>Construction Material <i>Materiales De Construcción</i></p> <p>Hazardous Waste <i>Residuos Peligrosos</i></p> </div>			

Waste Hauler Logo

STOP NO Hazardous Waste **STOP**

Please do not place hazardous waste materials in this bin.
Examples of items that are prohibited include:

- All batteries
- Paint
- Pesticides
- Household cleaners/chemicals
- Vehicle fluids (antifreeze, motor oil, etc.)
- Prescription drugs
- Sharps (syringes, lancets)
- All other hazardous waste labeled toxic, poison, corrosive, flammable, combustible or irritant

NO:       

Waste Hauler Logo

Residents may dispose of these materials for free by contacting (888) CleanLA or visit www.CleanLA.com



WARNING

NO SCAVENGING

**DO NOT REMOVE MATERIALS
PUNISHABLE BY FINE UP TO \$5,000**

Los Angeles County Code § 20.72.196
California Public Resources Code § 41953



ADVERTENCIA

**NO SE PERMITE
REBUSCAR**

**NO REMUEVA MATERIALES
CASTIGABLE CON MULTA DE HASTA \$5,000**

Código del Condado de Los Angeles § 20.72.196
Código de Los Recursos Públicos de California § 41953

Item 16.B.3 – Vehicle Billboards



Item 16.C.1 - Street and Alley Miles

Garbage Disposal District	Street Miles	Alley Miles
Lennox	20.96	0.26
Malibu	76.96	0.00

Please note that the proposer is still responsible for independently investigating service conditions in these areas.

Item 16.C.3.1 Public Receptacles Locations

Lennox Garbage Disposal District

PUBLIC CURBSIDE REFUSE COLLECTION AND DISPOSAL SERVICES
FOR ROAD MAINTENANCE DISTRICT 3 AREA

NO.	STREET	CROSS STREET	DIR	NS/FS	OTHER	TG	RD
1	111TH ST	HAWTHORNE BL	WB	FS	N/W CORNER	703-C6	233
2	HAWTHORNE BL	111TH ST	NB	FS	EAST SIDE	703-C6	233
3	HAWTHORNE BL	LENNOX BL	NB	NS	S/E CORNER	703-C6	233
4	HAWTHORNE BL	LENNOX BL	SB	NS	N/E CORNER	703-C6	233
5	INGLEWOOD AV	111TH ST	NB	FS	N/E CORNER	703-C6	233
6	INGLEWOOD AV	LENNOX BL	NB	NS	S/E CORNER	703-B6	233
7	INGLEWOOD AV	10109 INGLEWOOD AVENUE NO DUMPING SIGN	SB		WEST SIDE	703-B5	233
8	INGLEWOOD AV	104TH ST	SB	NS	N/W CORNER	703-B5	233
9	INGLEWOOD AV	HN 10521	SB		WEST SIDE	703-B5	233
10	INGLEWOOD AV	LENNOX BL	SB	FS	S/W CORNER	703-B6	233
11	INGLEWOOD AV	111TH ST	SB	FS	S/W CORNER	703-B6	233
12	LENNOX BL	HAWTHORNE BL	EB	FS	N/W CORNER	703-C6	233
13	LENNOX BL	FREEMAN AV	WB	FS	N/W CORNER	703-D6	233
14	LENNOX BL	BURIN AV	WB	FS	N/W CORNER	703-C6	233
15	LENNOX BL	GRIVILLEA AV	WB	NS	N/E CORNER	703-C6	233

NB NORTH BOUND
SB SOUTH BOUND
EB EAST BOUND
WB WEST BOUND
NS NEAR SIDE
FS FAR SIDE

Item 16.C.5.1 Customer Information

**ASSESSOR PARCELS AND REFUSE UNITS
LENNOX GARBAGE DISPOSAL DISTRICT
FISCAL YEAR 2017-18**

Parcel Use	No. of Parcels*	Total Refuse Unit**
Single Family	1,232	1,232
Vacant Land	34	28
Duplex	645	1,290
3 Units	150	450
4 Units	87	348
5 or More Units	143	1,642
Rooming Houses		
Mobile Home Parks		
Commercial	109	413
Industrial	23	90
Recreational	1	5
Churches/Colleges/Others	6	10
TOTAL	2,430	5,508

* Data based on Assessor's Use Code summary.

** Based on the Assessor's Land Use Code.

Item 16.C.6 - Tonnages *

Name of Garbage Disposal District	Solid Waste (in tons) Collected in 2016			Annual Clean-Up Tonnage in 2016	Abandoned Waste Tonnage in 2016
	Refuse **	Recyclables	Green Waste		
Lennox	12,211.90	632.58	645.32	37.9	703.15
Malibu	1,161.74	388.70	428.22		1.41

* The information contained in this table was reported by the current franchisee. However, the proposer is still responsible for independently investigating service conditions in these areas.

** These numbers include a portion of the bulky items that was disposed. Please note that information regarding the total number and actual tonnage of bulky items collected is not available.

Item 16.D.1 County and Contractor Letters

County Letter

(County Letterhead)

XXXX XX, 2017

Dear Property Owner/Tenant:

TRASH COLLECTION SERVICE FOR (NAME OF SERVICE AREA)

The County of Los Angeles Board of Supervisors recently awarded **(NAME OF NEW WASTE HAULER)** an exclusive seven-year franchise to provide trash collection and recycling services in carts to all single-family and two-unit residential properties within the unincorporated communities of **(NAME OF SERVICE AREA)** commencing on **XXXX XX, 2017**. As the administrator of the franchise, Public Works is committed to enhancing the quality of service in your community.

I am pleased to report that the monthly basic rate for standard service will be lowered to \$XX.XX. Please refer to the fact sheet in back of this letter for more information regarding your new service. In addition, **(NAME OF NEW WASTE HAULER)** will send a welcome packet further explaining the new services as well as information regarding the collection of current carts and delivery of new carts. All outstanding bills to your current waste hauler, **(NAME OF OLD WASTE HAULER)**, should be paid by **XXXX XX, 2017**.

Multifamily properties (three units or more, condominiums and town homes) and commercial properties have the option to receive their trash and recycling services by continuing bin/dumpster service through their existing hauler, subscribing with any of the County's authorized commercial franchise hauler, or may receive the new franchise cart service by contacting **(NAME OF NEW WASTE HAULER)** at the number below.

In addition, to ensure a successful and smooth transition, **(NAME OF NEW WASTE HAULER)** will be conducting community meetings in order to provide additional information and answer questions. Further details to these meetings will be provided by **(NAME OF NEW WASTE HAULER)** in the upcoming weeks and will also be posted at our website at www.CleanLA.com.

If you have any questions, please call our franchise hotline at 1(888) CLEAN LA (253-2652), Monday through Thursday, 7 a.m. to 5 p.m. You may also contact **(NAME OF NEW WASTE HAULER)** Customer Service Department at (800) XXX-XXXX, Monday through Friday, 7 a.m. to 5 p.m. and Saturday, 8 a.m. to 12 p.m.

Very truly yours,

GAIL FARBER
Director of Public Works

STEVEN E. MILEWSKI
Senior Civil Engineer
Environmental Programs Division

CW:



County of Los Angeles Department of Public Works

(NAME OF SERVICE AREA) TRASH COLLECTION FRANCHISE



When will the new franchise waste collection services begin?

The new services are scheduled to begin XXXX XX, 2017.

Who will be my new waste hauler?

(NAME OF NEW WASTE HAULER) will be your new waste hauler.

How was the new waste hauler selected?

The County utilizes a competitive process in selecting a waste hauler. Invitations are sent to all permitted waste haulers to submit proposals. The proposals are then evaluated based on specified criteria such as proposed rate, work plan, experience, financial strength, and other factors. This process ensures quality service at competitive rates.

What will my new rate be under the new agreement?

Beginning on (DATE OF FIRST DAY OF SERVICE), the rates will be \$XX.XX per month for basic service and \$XX.XX per month with senior discount (for qualifying seniors). These rates will be fixed for at least the first year of service.

What if I have questions?

Call (NAME OF NEW WASTE HAULER) Customer Service Department at (800) XXX-XXXX, call the County at 1(888) CLEAN LA (253-2652), or attend the community meetings.

What service features are included in the basic rate?

All (NAME OF NEW WASTE HAULER) customers receive:

- Once a week automated refuse, green-waste and recyclables collection service
- One 96-gallon trash cart, one 96-gallon green-waste cart, and one 96-gallon recyclables cart (carts smaller than 96-gallon are available upon request)
- One extra green-waste cart and/or one extra recyclable cart free of charge, upon request
- Additional carts beyond the allotted free carts can be requested at the low rate of \$5 per month
- Holiday Tree curbside collection service
- Annual curbside clean-up event (including electronic waste) for residential customers
- Four (4) on call pick-ups a year of bulky items
- Four (4) on call pick-ups a year of excess green-waste in bags and bundles
- Four (4) on call pick-ups a year of excess trash in bags
- SHARPS collection and disposal services for needle, lancets, etc. upon request
- Roll-out service for qualifying elderly and/or disabled customers, upon request
- 25 percent senior discount for heads of household 62 or older who either (a) qualify for utility rate discounts based on financial need or (b) generate small amounts of waste and use a 35-gallon cart for trash
- Collection and disposal of abandoned waste found in alleys and public right-of-ways
- Mulch and compost giveaways

Contractor Letter

(Waste Hauler Letterhead)

Dear Customer:

The County of Los Angeles Board of Supervisors recently awarded an exclusive seven-year franchise agreement to (NAME OF NEW WASTE HAULER) to provide trash collection and recycling services in carts to all single-family and two-unit residential properties within the (NAME OF SERVICE AREA) franchise area. Effective (XXXXXX XX, 2017), (NAME OF NEW WASTE HAULER) will be the new waste hauler for your community. We look forward to providing you the highest quality of solid waste and recycling services.

Standard services will include three new 96-gallon carts: one black for household trash, one blue cart for recyclables, and one green cart for green waste at a monthly rate of \$XX.XX per month, a savings of XX%. As a (NAME OF NEW WASTE HAULER) customer, you are also entitled to free on-call bulky item collections four times per year, holiday tree collection, and curbside community cleanups. Senior residents may be eligible for a 25% discount if they meet the criteria. For a summary of your new services and rates, enclosed are the Rate Sheet and Terms and Conditions. Please contact our Customer Service Department for additional information or to request special services such as roll-out/back yard service, discount (senior), smaller 64 or 32-gallon carts, or extra carts.

Your new 96-gallon carts will be delivered between the hours of 6:00 am to 6:00 pm on one of your trash collection days during the period of XXXXX XX, 2017 through XXXXX XX, 2017. Removal of your (NAME OF OLD WASTE HAULER) carts will occur simultaneously the same day. If delivery and removal do not occur by 6:00 pm, please take in your (NAME OF OLD WASTE HAULER) carts and remember to continue taking them out and leaving them at curbside up to 6:00 pm on the following trash collection day until they are removed and new (NAME OF NEW WASTE HAULER) carts are delivered. Please begin using your new (NAME OF NEW WASTE HAULER) carts as you receive them and (NAME OF OLD WASTE HAULER) will service them until October 31, 2014. (NAME OF NEW WASTE HAULER) will begin service under the new franchise agreement on XXXXX XX, 2017.

To better provide residents with information regarding services under the new franchise agreement and answer questions that residents may have, (NAME OF NEW WASTE HAULER) will be conducting community information meetings. These meetings will be held at the (NAME OF LOCATION AND ADDRESS), on the following dates:

- Thursday, XXXXX XX, 2017, at 6:00 p.m.
- Saturday, XXXXX XX, 2017, at 10:00 a.m.

(NAME OF NEW WASTE HAULER) is a family owned and operated local solid waste and recycling company serving Southern California since 1986. Our ownership is three generations strong with a combined total of close to 100 years' experience in the waste and recycling industry, and we look forward to providing your solid waste and recycling needs. We greatly appreciate the opportunity to provide quality service in your community.

Should you have any questions or concerns, please contact us toll-free at XXX-XXX-XXXX Monday through Friday from 7:00 am to 5:00 pm and Saturdays from 8:00 am to 12:00 pm.

Sincerely,
(NAME OF NEW WASTE HAULER)

Item 16.D.2 Non-Collection Notice

Hauler Logo

NON-COLLECTION NOTICE

Your container was not collected due to the reasons checked below. Please contact (Waste Hauler Name) customer service when corrections have been made.

- 1. Unpermitted waste such as household hazardous waste, electronic waste, batteries, and fluorescent tubes were placed in the containers. Contact the County of Los Angeles hotline at 1(800) Clean LA or visit their website at www.CleanLA.com for more information.
- 2. Due to unsafe service conditions.
- 3. ALL waste must be inside containers provided to you with the exception of pre-arranged bulky or excess item pick-ups.
- 4. Your containers or bulky item waste was not set out at the collection set out site.
- 5. Your container exceeds weight limitations (Waste Hauler to provide maximum weight restrictions for each size of cart and/or dumpster).
- 6. Your account is past due.
- 7. Premises are not safely accessible to vehicles.
- 8. Your recyclables (blue) container is contaminated with trash and/or green waste, and/or manure.
- 9. Your organics container is contaminated with trash and/or recyclables, and/or manure.
- 10. Your trash container is contaminated with manure.
- 11. Your manure container is contaminated with trash and/or recyclables, and/or organics.
- 12. Other: _____

If the above is corrected by 3:00 p.m. today, please contact our customer service department at (Waste Hauler Telephone Number) and we will return and collect today at no charge.

Item 16.D.2 Non-Collection Notice

Hauler Logo

NON-COLLECTION NOTICE

Your container was not collected due to the reasons checked below. Please contact (Waste Hauler Name) customer service when corrections have been made.

- 1. Unpermitted waste such as household hazardous waste, electronic waste, batteries, and fluorescent tubes were placed in the containers. Contact the County of Los Angeles hotline at 1/(833) Clean LA or visit their website at www.CleanLA.com for more information.
- 2. Due to unsafe service conditions.
- 3. ALL waste must be inside containers provided to you with the exception of pre-arranged bulky or excess item pick-ups.
- 4. Your containers or bulky item waste was not set out at the collection set out site.
- 5. Your container exceeds weight limitations (Waste Hauler to provide maximum weight restrictions for each side of cart and/or dumpster).
- 6. Your account is past due.
- 7. Premises are not safely accessible to vehicles.
- 8. Your recyclables (blue) container is contaminated with trash and/or green waste, and/or manure.
- 9. Your organics container is contaminated with trash and/or recyclables, and/or manure.
- 10. Your trash container is contaminated with manure.
- 11. Your manure container is contaminated with trash and/or recyclables, and/or organics.
- 12. Other: _____

If the above is corrected by 3:00 p.m. today, please contact our customer service department at (Waste Hauler Telephone Number) and we will return and collect today at no charge.

Item 16.D.3 Terms and Conditions

TERMS AND CONDITIONS

What We Will Collect. We will collect residential refuse, green waste, and recyclables in carts we provide, within one week of your requesting service. You must place refuse, recyclable materials, and organics in the appropriate carts. Materials placed outside of carts will not be picked up unless previous arrangements have been made.

When Carts are Allowed at Set-Out Site. Carts must only be placed at the set-out site for collection within the hours 5:00 p.m. on the day before scheduled collection and 8:00 p.m. on the day of collection or 2 hours after collection, whichever is later.

We Will Not Collect Hazardous Waste. State law prohibits disposal of hazardous materials and certain electronic devices in your trash. These include most paints, pesticides, petroleum derivatives such as motor oil and solvents, electronic devices such as cathode ray tubes (as in TV and computer monitors), LCD and plasma screens. Other items banned from disposal include batteries, thermostats, computers, telephones, answering machines, radios, stereo equipment, tape players/recorders, phonographs, videocassette players/recorders, calculators, aerosol cans, fluorescent lights, and certain mercury-containing devices. If these items are identified in your trash, your cart will be tagged and not serviced. Certain electronic devices may be separately collected. For additional safe and legal disposal options, call 1-888-CLEAN LA or visit www.CleanLA.com.

When We Will Collect. We will make collections once a week between the hours of 6:00 a.m. to 5:00 p.m. on the same day of the week (Monday through Friday) each week. If your scheduled collection day falls on or after a holiday, collection will be delayed during the holiday week by one day (Friday customers will have their collection on Saturday). The holidays we observe are Memorial Day, Independence Day, Labor Day, Thanksgiving, Christmas, and New Year's Day. Should there be a permanent change in your scheduled collection day, we will notify you in advance. If we miss your collection, please call us and we will return to pick it up, without charge, on the same day if you call before 3:00 p.m. or on the next collection day if you call after 3:00 p.m.

How Much We Will Charge. We will charge all our customers the rates shown on the Rate Sheet for standard services and any additional requested services.

Where We Will Pick Up. On your scheduled collection day, except if you have roll-out service, you must place your carts at the agreed set-out site with carts facing the street and 18 inches apart from each other. Handles and wheels must be facing the curb. If we agreed to collect on private driveways or pavement, we will ask you to sign a waiver of damage liability and/or indemnification.

How to Request Replacement for Stolen Carts. We will replace stolen carts within 7 days of customer's request. Carts will be replaced without additional charge provided the customer submits a police report. Otherwise, customer will be charged a fee.

How to Receive Roll-Out Service. We can bring your carts out to the pickup point, at no additional charge, for residential customers who certify they are not able-bodied or are elderly (over the age of 62) and have no able-bodied person residing in their household. Roll-out service will be provided to these customers during their weekly collection of trash, recyclable materials, and organics, as well as during the annual curbside clean-up event, holiday tree pick-ups, and additional on-call pickups. These services are also available to any other customer upon request at the charge listed on the rate sheet. We will ask you to sign a waiver of damage liability and/or indemnification prior to providing this service.

How to Change to Different Sized Carts. If you have space restrictions at your container storage or set-out site, you may request alternatives to 96 gallon carts, in the same aggregate capacity, free of charge.

Difficult to Service. At a charge listed on the rate sheet, this service is available to difficult to service areas, such as cul-de-sacs or hills, where automated collection vehicles cannot safely drive or to any other customer upon request.

Weight Limitations of Carts. The weight limit for each automated cart is as follows: 96 gallon cart = XXX lbs., 64 gallon cart = XXX lbs., 32 gallon cart = XXX lbs. If carts are found to be over these weight limits, they will be tagged and not serviced.

Annual Curbside Clean-Up Event. We will conduct a Clean-Up Event once per year wherein we will collect unlimited amounts of bulky items, excess solid waste, up to 3 passenger cars or pickup truck beds, and certain electronic devices free of charge. We will collect construction and demolition debris only if they are in up to two bags, containers, or bundles each weighing 70 pounds. Notification containing details of the Annual Clean-Up Event will be sent to customers at least two weeks in advance.

Holiday Tree Pickups. We will collect your holiday trees (such as Christmas trees and Hanukkah bushes) placed at the curb on your regularly scheduled collection day during the period of three weeks following December 25th. You must strip them of ornaments, garlands, tinsel, flocking and staves.

On-Call Bagged Green Waste Pickups. We will collect extra green waste set out at the curb on your next regularly scheduled pickup day if you call us at least 24 hours in advance. Green waste must be in bags or bound bundles less than 4 feet in length, up to 10 bags/bundles per pickup, four times per year at no additional charge.

On-Call Bagged Refuse Pickups. We will collect extra refuse set out at the curb on your next regularly scheduled pickup day if you call us at least 24 hours in advance. Refuse must be in bags, up to 5 bags per pickup, four times per year, at no additional charge.

On-Call Pickups of Bulky Items. We will collect bulky items set out at the curb on your next regularly scheduled pickup day if you call us at least 24 hours in advance. Bulky items will be picked up at no additional charge up to 4 times per year with a maximum of 10 items per pickup. Examples of bulky items include discarded furniture (such as chairs, sofas, mattresses, box springs, and rugs); appliances (such as refrigerators, range, washers, dryers, water heaters, dishwashers, plumbing, and other similar items); and construction and demolition debris in up to two 70-pound containers.

Additional On-Call Pickups of Bulky Items. We will collect bulky items, in excess of four times per year, on your next regularly scheduled pickup day, at the charges listed on your rate sheet, if you call us at least 24 hours in advance.

Additional Customer Options Regarding Recyclables. Customers may donate or sell any or all of their recyclables to persons other than this waste hauler.

When You Must Pay. Residents are billed for services three months in advance. We mail you your bill on or after the first day of your billing period, for example, on April 1 for the billing period of April, May, and June. Your bill is due no later than the last day of the first month, for example, on April 30. If we do not receive payment by the last day of the second month, for example, on May 31, your bill will become delinquent and an additional 10% fee will be added to the balance. We may terminate your service if you do not timely pay your service fees. There will be a charge of \$25.00 for interruption of service and a \$25.00 fee on returned checks.



Customer Termination Rights and Right to Self-Haul. You may terminate service without cause at any time by giving us 21-day notice. You also have the right to self-haul your waste instead of subscribing to our service.

To receive additional information regarding these terms and conditions of your service, please call us toll-free at 1-888-XXX-XXXX between 7am and 5pm weekdays, except holidays and from 7am to 12pm on Saturday. You may come to our office located at WASTE HAULER ADDRESS or you may mail correspondence to our office address. If we do not satisfactorily resolve any complaint, you may call the County at 1-888-CLEAN LA (or 253-2552).

Thank you for allowing (WASTE HAULER NAME) to serve you!

Item 16.D.4.a – Residential Service Brochure

<p>HOLIDAY TREE COLLECTION Collection of holiday trees (i.e., Christmas trees, Hanukkah bush, etc.) from the curb on regularly scheduled collection day.</p> <p>ANNUAL CURBSIDE CLEANUP A cleanup event scheduled once per year wherein all bulky items, excess trash, and excess green waste will be collected from the curb.</p> <p>MOVE IN/MOVE OUT Bulky items, up to a maximum of 10 items per pickup, will be collected within 14 days of customer account being opened or closed.</p> <p>SHARPS COLLECTION Upon receiving request from customer, up to four Sharps containers per year will be provided, along with a pre-paid postage container to mail back filled Sharps containers for disposal.</p> <p>MULCH AND COMPOST EVENTS A drive up event wherein customers can receive mulch and/or compost. Dates and details of the events will be announced two weeks in advance.</p> <p>ROLL-OUT SERVICES For qualified elderly and disabled customers, carts will be rolled out from customer's storage to the collection vehicle then back to storage at no additional cost. This service is available for other customers, upon request, for a charge listed on the rate sheet.</p> <p>HOUSEHOLD HAZARDOUS WASTE COLLECTION FOR ELDERLY AND DISABLED Upon request from qualified customer, household hazardous waste will be collected from set out site agreed upon with the customer.</p>	<p style="text-align: center;">WHO TO CONTACT</p> <p style="text-align: center;">WASTE HAULER</p> <p style="text-align: center;">For service questions or requests: Please contact your waste hauler.</p> <p style="text-align: center;">PUBLIC WORKS</p> <p style="text-align: center;">For general or environmental questions or for customer service complaints: 1(888) CleanLA or www.CleanLA.com</p>	<p style="text-align: center;">A Guide to Trash Service</p>  <p style="text-align: center;">Residential Trash and Recyclables Program</p> <p style="text-align: center;">Unincorporated Los Angeles County Communities</p>	<p style="text-align: center;">BASIC SERVICES INCLUDED</p> <p>WASTE COLLECTION Automated collection of trash, recyclables, and organics each week on a regular collection day(s).</p> <p>CARTS Set of one 64 gallon black, one 96 gallon blue, and one 96 gallon green cart are provided.</p> <p>EXTRA CARTS AT NO ADDITIONAL CHARGE Upon request, One additional 96 gallon blue and/or one additional 96 gallon green carts.</p> <p>ALTERNATIVE SIZE CARTS Upon request, if you have space limitations, you may receive either 64 or 32 gallon carts.</p> <p>BULKY ITEM PICK-UP Up to four times per year, with a maximum of 10 items per pickup, bulky items (i.e., refrigerators, couches, etc.) will be collected upon a minimum of 24 hour notice by calling our customer service department.</p> <p>EXCESS TRASH PICKUP Up to four times per year, with a maximum of 5 bags per pickup will be collected upon a minimum of 24 hour notice by calling our customer service department.</p> <p>EXCESS GREEN WASTE PICKUP Up to four times per year, with a maximum of 10 bags per pickup will be collected upon a minimum of 24 hour notice by calling our customer service department.</p>
---	--	--	---

<p style="text-align: center;">Black Cart is for Trash</p>  <p>Your BLACK cart is for trash. Do not place trash in the Blue Recycling or Green Organics cart or it will not be collected. Additional trash carts are available, upon request, for a surcharge listed on the rate sheet. If your cart is damaged, it will be repaired or replaced at no charge.</p> <p>DO NOT place the following materials in the black carts:</p> <ul style="list-style-type: none"> Batteries Construction and Demolition Debris Electronic Waste Fluorescent Bulbs Green Waste Infectious Waste Oil Paint Pesticides Recyclables Tires <p>For information on proper disposal of household hazardous waste, please call 1(888) Clean LA or visit the County's website at www.CleanLA.com.</p>	<p style="text-align: center;">Blue Cart is for Recyclables</p>  <p>Your BLUE cart is for recyclables. One additional Recyclable cart is available upon request, at no additional charge.</p> <p>Recyclable items include:</p> <ul style="list-style-type: none"> Aluminum and metal Aluminum cans Aluminum foil Brochures Catalogs Cardboard Computer paper Glass Glass bottles and jars Junk mail Magazines Mixed paper Newspaper Paper Paper tubes Plastic soda or water bottles Tissue boxes Phone books #1 #7 Plastic bottles Used envelopes <p>REMINDER: Please do not put trash in the Blue or Green carts</p>	<p style="text-align: center;">Green Cart is for Green Waste</p>  <p>Your GREEN cart is to be used for green waste materials only. Please do not place bagged green waste in the green cart.</p> <p>Green waste items include:</p> <ul style="list-style-type: none"> Branches Brush Grass clippings Leaves Tree trimmings <p>DO NOT place the following materials in the black carts:</p> <ul style="list-style-type: none"> Animal waste Cactus Construction debris Garbage Palm fronds Palm tree trimmings Plastic or paper bags 	<p style="text-align: center;">FREQUENTLY ASKED QUESTIONS</p> <p>Who do I call to request services such as bulky item collection or replacement of damaged carts?</p> <p>All service requests, including replacement of damaged carts, must be made directly with the waste hauler.</p> <p>What happens if my waste hauler mixes my recyclable materials with the trash?</p> <p>Waste haulers are required to collect separately the trash, recyclable materials, and green waste. If you observe your waste hauler mixing recyclables or green waste with trash, we request that you please contact Public Works. Haulers found in violation may be fined for each occurrence. To ensure contract compliance, Public Works will have inspectors assigned to monitor trash collection in your area.</p> <p>Who can I call if I have a complaint about the trash collection services I receive?</p> <p>Residents are encouraged to contact the waste hauler first to resolve issues concerning the delivery of service. If the waste hauler fails to resolve any issue, please contact Public Works.</p> <p>How will the County ensure the residents receive quality service from the hauler?</p> <p>The County will monitor compliance with the service standards prescribed by the trash collection agreement and ensure residents receive quality service. Waste haulers who fail to meet these standards may be assessed fines or have their agreement terminated by the County for poor performance.</p>
---	--	---	---

Item 16.D.4.b – Multifamily Service Brochure

Request a Consultation Solicite una Consulta



We offer FREE on-site evaluations aimed at increasing recycling and reducing waste generated on your premises. The visit will help customize recycling and containers to meet your needs.

Ofrecemos GRATIS una visita a sus instalaciones para determinar como puede reducir más y reducir la basura que genera. Durante la visita también identificaremos el programa de reciclaje y los carritos o contenedores de basura más adecuados a sus necesidades.

Important Notice! If you do not use Republic Services as your trash collection provider, you could be incurring an additional and unnecessary expense since trash collection services required by the county of Los Angeles in your Garbage Disposal District are paid for by the property owner as a service fee charge on the parcel's property tax bill. Please also note the County does not provide service fee reimbursements to property owners who choose to receive services from a different waste hauler. Please call 800-299-4898 for further information or assistance.

Aviso importante: Si usted no ocupa a Republic Services como su proveedor para el servicio de la colecta de basura, es posible que esté incurriendo un gasto adicional e innecesario ya que los servicios de colecta de basura requeridos por el Condado de Los Angeles en su distrito de desecho de basura son cubiertos por el dueño de la propiedad como un cargo por cuota de servicio incluidos en la factura de los impuestos de la propiedad. Por favor tenga en cuenta que el Condado no da reembolsos a los dueños de propiedades que eligen recibir los servicios de un proveedor diferente. Por favor llame al 800-299-4898 para recibir más información o ayuda.

To request containers, services, bulky item pick up, or consultation, contact:

Para solicitar carritos de basura, servicios, recolección de artículos grandes o una visita a sus instalaciones, por favor llame al

Customer Service
Departamento de Servicio al Cliente



800-299-4898

site.republicServices.com/site/los-angeles-ca

reduce waste and increase recycling

As your waste hauler, we are ready to meet your needs for recycling needs. Read this brochure about our services and the new mandatory recycling law.

Como el proveedor del servicio para la recolección de su basura, estamos listos para atender sus necesidades para el reciclaje en la ciudad y el reciclaje. Lea esta información acerca de nuestros servicios y acerca de la nueva ley mandatoria sobre el reciclaje en California.



MULTI-FAMILY RECYCLING SERVICES

for Multi Family units within
the Belvedere Garbage Disposal District
para unidades de multi-familiares dentro del Distrito de
Desecho de Basura de Belvedere



**REPUBLIC
SERVICES**

800-299-4898

site.republicServices.com/site/los-angeles-ca

Recycling Services

The Law States:

La Ley Estipula:

To conserve our remaining landfill space and natural resources, California adopted Assembly Bill 341 which sets a Statewide recycling goal of 75% and mandates recycling in the commercial sector. Effective July 1, 2012, businesses that produce at least 4 cubic yards of trash a week must participate in recycling through one of the following:

- Subscribe to service that collects recyclables separately.
- Send materials to a mixed waste processing facility that diverts recyclables.
- Self-haul your own recyclables.

Para ahorrar espacio en las verteduras y conservar recursos naturales, California ha aprobado la propuesta de la asamblea 341, la cual establece una meta a lo largo del estado de reciclaje del 75% para el sector comercial. A partir del primero de julio del 2012, todas las unidades, multi-familiares (de más de cinco unidades) deben contar con un programa de reciclaje a través de una de estas opciones:

- Contratar un servicio que recoge reciclables por separado.
- Enviar los reciclables a una empresa que acepte basuras mezclada y separe los reciclables o
- Llevar sus propios carritos de reciclaje.

Our services include:

Nuestros servicios incluyen:

- Free on-site trash assessment de basura
- FREE recyclable collection. Recolección GRATIS de reciclables.
- Recycling containers. Carritos de reciclaje.
- Bulk item collection. Recolección de artículos grandes.
- Site & site consultation. Visita a sus instalaciones.
- Bulk item pick up. Recolección de artículos grandes.
- Bin Exchange. Intercambio de carritos.



What Items Are Recyclable?

Yes

- Paper: newspapers, magazines, catalogs
- Clean, flattened cardboard
- Aluminum: soft drink cans, latas de aluminio
- White & colored paper
- Newspapers, Magazines, catalogs
- Paperboard: cardboard
- Junk mail, envelopes



Why recycle?

¿Por qué reciclar?

- It conserves natural resources and landfill space. Para ahorrar espacio en los verteduras y conservar recursos naturales.
- It protects the environment. Para proteger al medio ambiente.

No

- Waxed paper: cups, lids, etc. Productos encerados.
- Styrofoam. Productos de Unisel.
- Waxed cardboard. Cartoncillos de papel encerado.
- Plastic binders. Carpetas de plástico.
- Carbon paper. Papel carbon.
- Food wrappers. Envolturas para comida.
- Paper towels. Toallas de papel.
- Photographs. Fotografías.
- Hazardous waste. Basura tóxica del hogar.



- It is mandatory for multi family dwellings (5 or more units). Porque es obligatorio para unidades multi-familiares (de más de cinco unidades).

Available container sizes

Tamaños de contenedores disponibles

As a Belvedere GDD customer, you are entitled to free recycling collection based on your parcel size and refuse unit allotment.

Por ser cliente de GDD Belvedere, tiene derecho a una colecta gratis de reciclajes de acuerdo al tamaño de su parcela y a la unidad de desecho designado.



1-3 cubic yard containers
1-3 contenedores yardas cúbicas

OR



96-gallon carts
when space is tight
carritos de 96 galones cuando el espacio es limitado

If you have any questions please contact:
Si usted tiene alguna pregunta, por favor comuníquese:

800-299-4898



residential & multi-family dwelling

Item 16.D.4.c – Commercial Service Brochure

SERVICES INCLUDED

All commercial properties in the Garbage Disposal District are entitled to the weekly services below. Contact your waste hauler for any questions.

WASTE COLLECTION
Collection of trash, green waste and recyclables each week on a regular collection day(s).

TRASH CARTS OR DUMPSTERS
Dumpsters or sets of plastic carts, in appropriate sizes and quantities, are provided based on property land use codes.

BULKY ITEM PICK-UP
Bulky items (i.e., refrigerators, couches, etc.) generated onsite and set curbside.

ELECTRONICS COLLECTION
Old electronics (i.e., computers, monitors, copiers) set curbside.

CONSTRUCTION DEBRIS
Up to 60 pounds of construction and demolition debris generated onsite and set curbside.

PUBLIC RECEPTACLES
Routine collection of discards in curbside public receptacles twice a day, six days a week.

SIDEWALKS, PARKWAYS, & ALLEYS
Routine removal of abandoned waste and sweeping of alleys.

OTHER SERVICES
Include mulch and compost giveaways, electronics and clothing drop off events, collection of holiday trees following Christmas, and biannual site visit to review waste disposal practices.

WHO TO CONTACT

WASTE HAULER

For service questions or requests:
Please contact your waste hauler.

PUBLIC WORKS

For general or environmental questions or for customer service complaints:
(888) CleanLA or CleanLA.com

County of Los Angeles
Department of Public Works
Environmental Programs Division
900 S. Fremont Ave.
Alhambra, CA 91803

www.CleanLA.com
@CleanLA

Enrich lives through effective and caring service

A Guide to Trash Service for your Business

Garbage Disposal Districts

Garbage Disposal Districts

The Garbage Disposal District is an area within the unincorporated County of Los Angeles where an allocated level of trash, recycling, and green waste collection and other services are provided to residents and businesses by a private waste hauler who contracts with the County of Los Angeles.

The Department of Public Works, Environmental Programs Division oversees the contract.

All property owners in a GDD are enrolled for services and assessed on their annual property tax bill.

The level service and the amount charged is based on the land use codes assigned to the property by the County of Los Angeles Office of the Assessor. See the table for a list of property types and the allocated trash service.

Any extras beyond the allocated service is arranged with and paid to the waste hauler.

Container Sizes

Businesses may use metal dumpsters, often 2 or 3 cubic yards in capacity, or sets of 96 gallon carts in equivalent capacity (limited to available sizes).

Frequency

Businesses receive collection service once per week except:

- Properties with 2.5 cubic yards or more of service are entitled to receive collection service twice a week.
- Properties classified by the Assessor as Commercial food establishments are entitled to daily collection service of waste, excluding Sundays and holidays.

Multiple Businesses on 1 Property

If there are multiple businesses on one property, the specific business type may be different from the assigned property land use code (i.e. a restaurant in a shopping center) and the property owner/property management company should contact Public Works to verify the allocated level of trash service.

FREQUENTLY ASKED QUESTIONS

What is the current service rate?
Since 2007, charges for waste collection services in the Garbage Disposal Districts have remained constant. Please refer to your annual tax bill for the amount.

How were service levels determined?
Service levels assigned to parcels are based on the type of land use, according to the Office of the Assessor's data. They are based on the classification of a particular property (e.g., restaurant, store, or shopping center).

Can I use another hauler?
Yes, you are not required to use collection services provided through the district. However, no refunds are available for the charges collected on the property tax bill for the property owner's choice of haulers or non use of the allocated GDD services.

Can my restaurant get daily service?
Yes, but if the property's land use code by the Office of the Assessor is not listed as a restaurant, you are not paying for daily service on the taxes and therefore it is considered an additional service.

My business is in the GDD. Can I get trash service for free?
Maybe. The GDD trash service is provided to all property owners, not all business owners. You must speak to the property owner. Also, basic trash service is determined by land use codes, not what business is operating and there may be discrepancies.

Can I get more trash service?
Sure but there will be a service charge for additional service (larger capacity or increased frequency) beyond the allocated service assessment paid for on the property tax bill. Please refer to the allocation table of services.

Land Use	Code	Code
Public Works	001	001
Public Works	002	002
Public Works	003	003
Public Works	004	004
Public Works	005	005
Public Works	006	006
Public Works	007	007
Public Works	008	008
Public Works	009	009
Public Works	010	010
Public Works	011	011
Public Works	012	012
Public Works	013	013
Public Works	014	014
Public Works	015	015
Public Works	016	016
Public Works	017	017
Public Works	018	018
Public Works	019	019
Public Works	020	020
Public Works	021	021
Public Works	022	022
Public Works	023	023
Public Works	024	024
Public Works	025	025
Public Works	026	026
Public Works	027	027
Public Works	028	028
Public Works	029	029
Public Works	030	030
Public Works	031	031
Public Works	032	032
Public Works	033	033
Public Works	034	034
Public Works	035	035
Public Works	036	036
Public Works	037	037
Public Works	038	038
Public Works	039	039
Public Works	040	040
Public Works	041	041
Public Works	042	042
Public Works	043	043
Public Works	044	044
Public Works	045	045
Public Works	046	046
Public Works	047	047
Public Works	048	048
Public Works	049	049
Public Works	050	050
Public Works	051	051
Public Works	052	052
Public Works	053	053
Public Works	054	054
Public Works	055	055
Public Works	056	056
Public Works	057	057
Public Works	058	058
Public Works	059	059
Public Works	060	060
Public Works	061	061
Public Works	062	062
Public Works	063	063
Public Works	064	064
Public Works	065	065
Public Works	066	066
Public Works	067	067
Public Works	068	068
Public Works	069	069
Public Works	070	070
Public Works	071	071
Public Works	072	072
Public Works	073	073
Public Works	074	074
Public Works	075	075
Public Works	076	076
Public Works	077	077
Public Works	078	078
Public Works	079	079
Public Works	080	080
Public Works	081	081
Public Works	082	082
Public Works	083	083
Public Works	084	084
Public Works	085	085
Public Works	086	086
Public Works	087	087
Public Works	088	088
Public Works	089	089
Public Works	090	090
Public Works	091	091
Public Works	092	092
Public Works	093	093
Public Works	094	094
Public Works	095	095
Public Works	096	096
Public Works	097	097
Public Works	098	098
Public Works	099	099
Public Works	100	100

Item 16.D.5 Rate Sheet

(WASTE HAULER LOGO)

Rate Sheet

XXXX 1, XXXX

To Our Valued (NAME OF SERVICE AREA) Customer:

The County of Los Angeles Board of Supervisors awarded (NAME OF WASTE HAULER) a contract to provide trash collection services in the (NAME OF SERVICE AREA) unincorporated community. The term of this contract is 7 years with two 2-year renewal options for a potential total contract term of eleven years. The initial 7-year term commenced on XXXX 1, 20XX and will end on XXXX 31, 20XX.

Customers will be charged the rates shown below on a quarterly basis. (NAME OF WASTE HAULER) bills for services three months in advance. To request additional services or if you have any questions or concerns, please do not hesitate to call (WASTE HAULER NAME) customer service department, Monday thru Friday 8:00 a.m. to 5:00 p.m. or Saturday 8:00 a.m. to 1:00 p.m., at 1-800-XXX-XXXX.

Basic Service Fee: _____ \$XX.XX/quarter (\$XX.XX/month)

Basic Service Fee with Senior Discount ⁽¹⁾: _____ \$XX.XX/quarter (\$XX.XX/month)

⁽¹⁾A Senior Discount of 25% will be given to residents who meet the following criteria: head of household, 62 or older, and who either (a) qualify for utility rate discounts based on financial need or (b) generate small amounts of waste and use a 32-gallon cart for trash.

Additional Services and Surcharges: These services are available upon request.

Manure Service	\$XX.XX/quarter (\$XX.XX/quarter with senior discount)
Bear-Resistant Cart	\$XX.XX/quarter (\$XX.XX/quarter with senior discount)
Recyclables Cart with Gravity Lock	\$XX.XX/quarter (\$XX.XX/quarter with senior discount)
Additional Containers Above Basic Service, each:	\$XX.XX/quarter (\$XX.XX/quarter with senior discount)
Additional (more than four/year) on-call collection of bulky items, excess trash, and excess green waste	\$XX.XX/collection (\$XX.XX/quarter with senior discount)
Difficult to Service: For any customer who requests this service or for difficult-to-service residential premises (such as hills or cul-de-sacs where collection vehicles cannot safely drive):	\$XX.XX/quarter (\$XX.XX/quarter with senior discount)
Roll-out/backyard service: This service means (WASTE HAULER NAME) brings containers to the curb to be serviced by collection vehicle and returned to the back yard or other designated location for an additional fee of:	
For Qualifying Customers:	Free
Minimum Service (0 to 10 Feet):	\$XX.XX/quarter (\$XX.XX/quarter with senior discount)
Full Service (11 Feet to 50 Feet):	\$XX.XX/quarter (\$XX.XX/quarter with senior discount)
Extended Full Service:	\$XX.XX/quarter (\$XX.XX/quarter with senior discount)

Other Discounts Available to Qualifying Customers:

5% Smarte-Club Discount for residents who register to receive service information, billing, and make service requests electronically through (WASTE HAULER NAME)'s website at (WEBSITE ADDRESS). Residents who register must waive to receive these materials by mail and must be a member during an entire, applicable billing quarter to receive this discount.

15% Small Generator Discount for residents who use only one 32-gallon container for trash. This discount cannot be combined with the Senior Discount.

Residential Bin Rentals (3 YD) and Temporary Roll-Off Services: Available upon request by calling our customer service department at 1-800-266-7551.

Item 16.E.3 - Form T



**Monthly
SOLID WASTE COLLECTION (TASK 2) FORM
FOR THE LOS ANGELES COUNTY UNINCORPORATED AREAS
For Use by Residential Franchise/Garbage Disposal District Waste Haulers**

FORM T

Hauling Company Name: _____ Reporting Period (Month / Year): _____

Facility Address: _____

Phone No.: (____) _____

Signature: _____

GDD or Residential Franchise Area	Trash/Bulky Items (Tons)		E-Waste (Tons)		Tires (Tons)		Grand Total Disposed	Grand Total Diverted	Grand Total Collected	Public Receptacles (Total Tons Collected)	Mattresses (Total Quantities Collected)
	Disposed	Diverted	Disposed	Diverted	Disposed	Diverted					
Total											
Facility Materials Taken To:											
Disposed											
Diversion											

